

# MATEMATIKA

## 6

*Umumiy oʻrta taʼlim maktablarining  
6-sinfi uchun darslik*

Oʻzbekiston Respublikasi  
Xalq taʼlimi vazirligi  
nashrga tavsiya etgan

Yangi nashr

TOSHKENT – 2022

UO'K 51(075.3)  
KBK 22.1ya72  
M 31

### Tuzuvchilar:

*Shuhrat Ismailov, Dilshod Aroyev, Isroil Tillaboyev,  
Lolaxon O'rinboyeva, Baxromjon Bozarov, Anvarjon Kenjayev,  
Shahnoz Yusupjonova, Hasan Nasriddinov*

### Xalqaro ekspert:

Marcelo Staricoff

### Taqrizchilar:

- I. A. Teshaboyev** – Farg'ona viloyati Oltiariq tumanidagi 3-ixtisoslashtirilgan davlat umumta'lim maktab-internati matematika fani o'qituvchisi.
- Q. Q. Qosimov** – Namangan viloyati Chortoq tumanidagi 5-ixtisoslashtirilgan davlat umumta'lim maktab-internati matematika fani o'qituvchisi.
- Q. F. Abdullayev** – Qashqadaryo viloyati G'uzor tumanidagi 68-ixtisoslashtirilgan davlat umumta'lim maktabi matematika fani o'qituvchisi.

Matematika 6-sinf [Matn]: darslik / Sh. Ismailov [va boshq.] – Toshkent: Respublika ta'lim markazi, 2022. – 240 b.

UNICEFning O'zbekistondagi vakolatxonasi  
bilan hamkorlikda tayyorlandi.

O'zbekiston Respublikasi Fanlar akademiyasi V. I. Romanovskiy nomidagi  
matematika instituti xulosasi asosida takomillashtirildi.

Original maket va dizayn konsepsiyasi  
Respublika ta'lim markazi tomonidan ishlandi.

Respublika maqsadli kitob jamg'armasi mablag'lari hisobidan chop etildi.

### SHARTLI BELGILAR



— eslaymiz



— amaliy topshiriq



— guruhlarda ishlaymiz



— qiziqarli matematika



— yangi ma'lumotlar



— mustahkamlaymiz

n\*

— murakkab topshiriqlar



— mustaqil ish

# MUNDARIJA

## 5-SINFDA O'TILGANLARNI TAKRORLASH

7



Natural sonlar ustida amallar.....	8
Tub va murakkab sonlar. EKUB va EKUK.....	10
Bir xil maxrajli kasrlarni qo'shish va ayirish .....	12
Geometrik shakl va o'lchashlar.....	14

## I BOB. KASRLARNI QO'SHISH VA AYIRISH

17

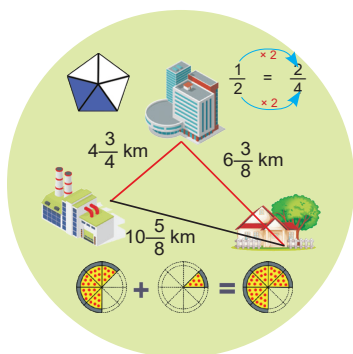

Teng kasrlar .....	18
Kasrlarni qisqartirish .....	20
Kasrlarni umumiy maxrajga keltirish.....	22
Har xil maxrajli kasrlarni taqqoslash .....	25
Har xil maxrajli kasrlarni qo'shish .....	27
Har xil maxrajli kasrlarni ayirish .....	30
Aralash sonlarni qo'shish va ayirish .....	33

## II BOB. KASRLARNI KO'PAYTIRISH VA BO'LISH

37

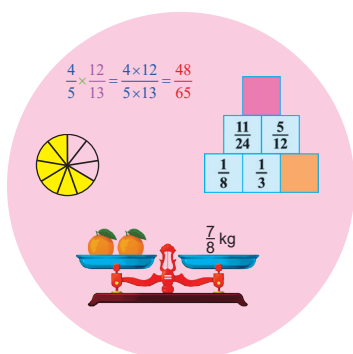

Kasrlarni ko'paytirish .....	38
Aralash sonlarni ko'paytirish.....	42
Sonning qismini topish.....	45
Qulay usullarda hisoblash .....	48
O'zaro teskari sonlar.....	51
Kasrlarni bo'lish .....	53
Aralash sonlarni bo'lish.....	56
Qismiga ko'ra sonni topish .....	59
Kasrlar ustida amallarga doir topshiriqlar .....	61

## III BOB. O'NLI KASRLARNI KO'PAYTIRISH VA BO'LISH

66

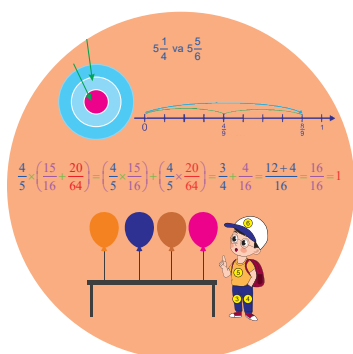

O'nli kasrni natural songa ko'paytirish .....	67
O'nli kasrni 10 ga, 100 ga, 1000 ga ko'paytirish.....	70
O'nli kasrlarni ko'paytirish.....	72
O'nli kasrni natural songa bo'lish.....	75
O'nli kasrni 10 ga, 100 ga, 1000 ga bo'lish .....	77
O'nli kasrlarni bo'lish.....	79
Kasrni o'nli kasrga keltirish .....	83
Davriy kasrlar.....	85
O'nli kasrlarni yaxlitlash .....	87
O'nli kasrlar ustida amallarga doir topshiriqlar.....	89
Loyiha ishi.....	92

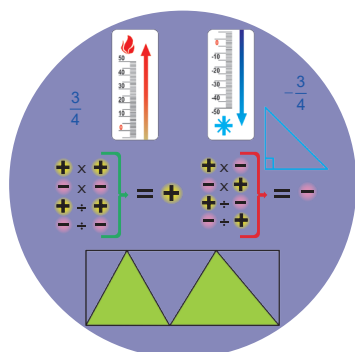

Musbat va manfiy sonlar.  
Butun sonlar haqida tushuncha ..... 94  
Musbat va manfiy butun sonlarni son o'qida tasvirlash .. 97  
Sonning moduli ..... 99  
Butun sonlarni taqqoslash ..... 102  
Butun sonlarni qo'shish ..... 104  
Butun sonlarni ayirish ..... 108  
Butun sonlarni ko'paytirish..... 112  
Butun sonlarni bo'lish ..... 114  
Butun sonlar ustida amallarga doir topshiriqlar ..... 116

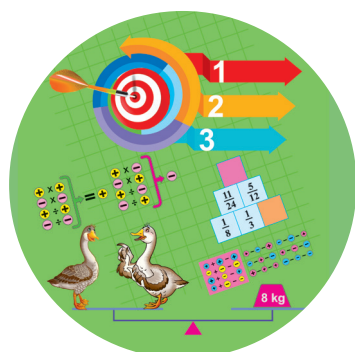

Ratsional son haqida tushuncha ..... 120  
Ratsional sonlarni qo'shish..... 123  
Ratsional sonlarni ayirish..... 126  
Ratsional sonlarni ko'paytirish ..... 128  
Ratsional sonlarni bo'lish..... 131  
Ratsional sonlar ustida amallarga doir topshiriqlar..... 133  
PISA test savollari asosida o'zingizni sinab ko'ring ..... 136  
Loyiha ishi..... 137

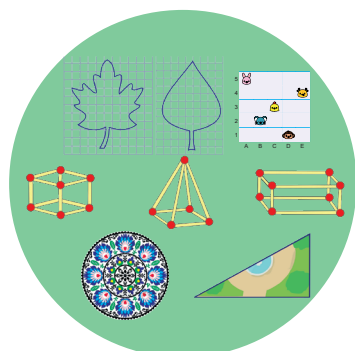

Dekart koordinatalar sistemasi ..... 139  
Koordinatalar sistemasida shakllar yasash ..... 142  
Uchburchak, uning elementlari va perimetri ..... 144  
Uchburchak turlari ..... 147  
Uchburchakning yuzi ..... 151  
Katakli qog'ozda yuzlarni hisoblash..... 155  
Aylana va doira ..... 159  
Aylana uzunligi va doira yuzi ..... 163  
Murakkab shakllarning yuzinini hisoblash ..... 166  
Fazoviy shakllar hajmi ..... 169  
O'lchov birliklari orasidagi munosabatlar ..... 172

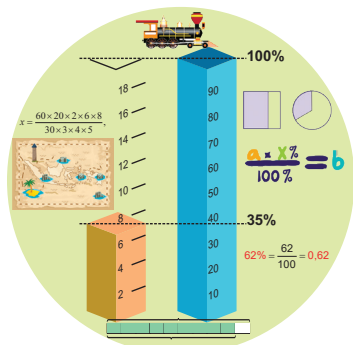

Nisbat ..... 176

Proporsiyalar. Proporsiyaning asosiy xossasi ..... 179

Proporsiyaning asosiy xossasi tatbiqlari..... 181

Foizlar..... 184

Sonning foizini va foiziga ko'ra sonni topish..... 187

Foizlarni hisoblashga oid masalalar ..... 189

To'g'ri va teskari proporsional miqdorlar ..... 191

To'g'ri va teskari proporsional miqdorlarning tatbiqlari.... 194

Masshtab ..... 195

Loyiha ishi..... 198

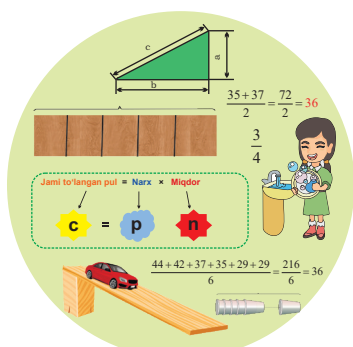

Sonli va harfli ifodalar ..... 200

Tengliklar ..... 203

Tenglamalar va ularning xossalari ..... 205

Iqtisodiy mazmundagi masalalar ..... 208

Bajarilgan ishga doir masalalar ..... 211

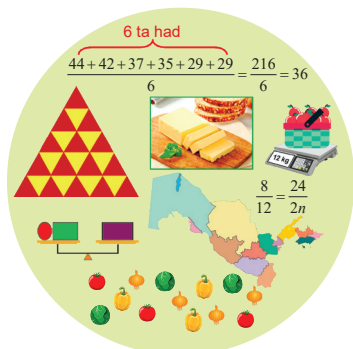

Jadvallar. Jadvallarni o'qish va tuzish..... 214

Ma'lumotlar qatori ..... 216

Ma'lumotlar tahlili..... 219

TAKRORLASH ..... 223

QIZIQARLI VA MANTIQUIY MASALALAR..... 230

XALQARO BAHOLASH DASTURIGA OID

TOPSHIRIQLAR ..... 234



6-SINF "MATEMATIKA"  
DARSLIGI UCHUN TA'LIMIY  
O'YINLAR



6-SINF "MATEMATIKA"  
DARSLIGI UCHUN  
VIDEODARSLAR

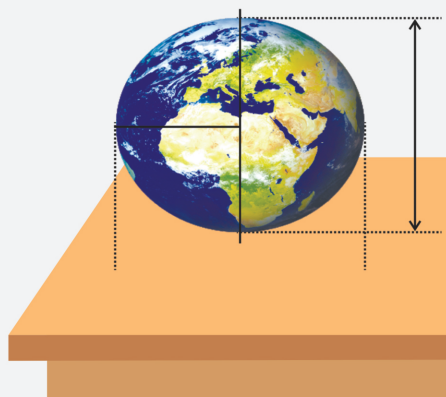
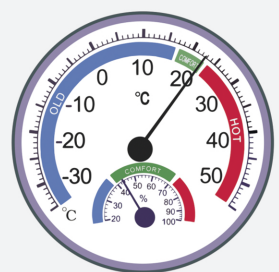
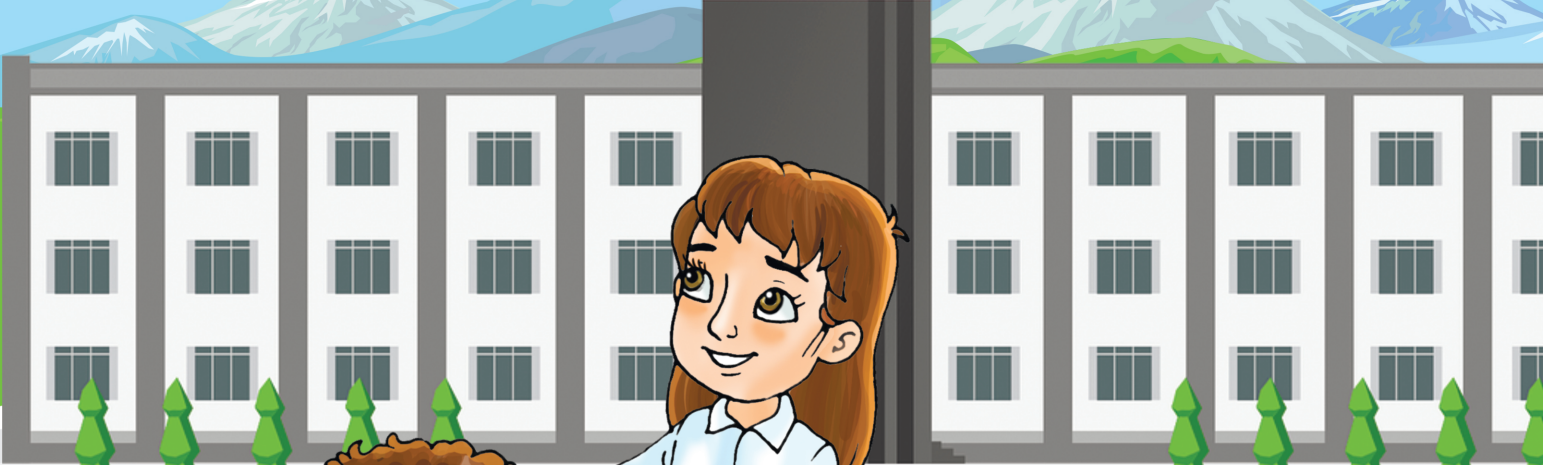

# 5-SINFDA O'TILGANLARNI TAKRORLASH

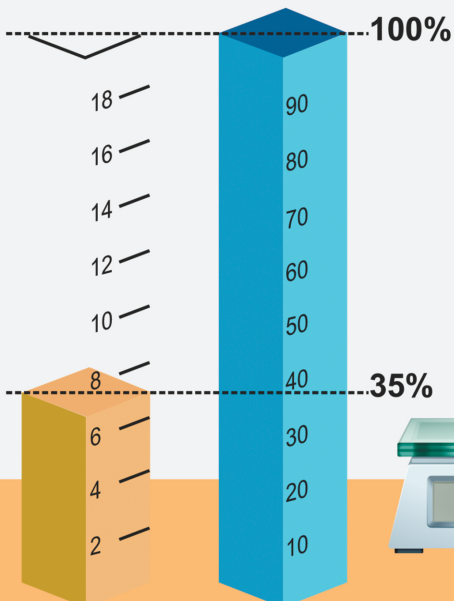
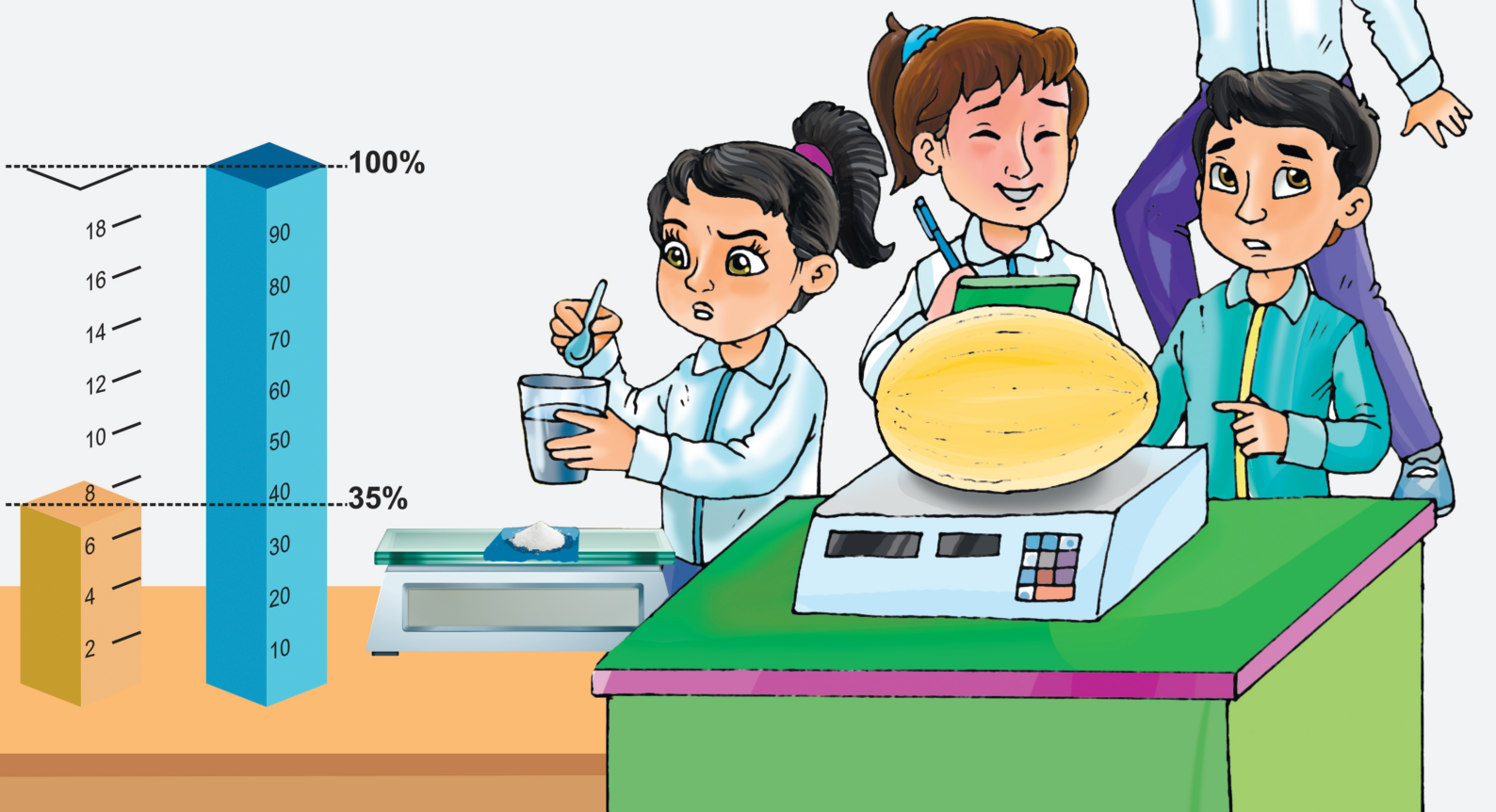
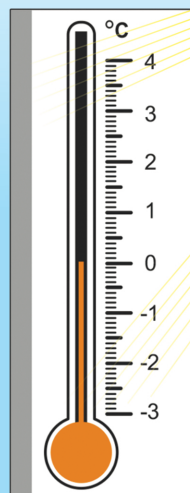

## NATURAL SONLAR USTIDA AMALLAR



### Eslaymiz!

Sonlar xona birliklariga qanday ajratilgan?



Sonlar nomi	milliardlar			millionlar			minglar			birlar		
Xonalari nomi	yuzlar	o'nlar	birlar	yuzlar	o'nlar	birlar	yuzlar	o'nlar	birlar	yuzlar	o'nlar	birlar
Son	2	9		4	0	5	3	7	8	6	1	3
O'qilishi	29 milliard			405 million			378 ming			613		

Yoziishi: 29 405 378 613

### 2. Amallar qanday bajarilgan? Tushuntiramiz.

o'n minglar	minglar	yuzlar	o'nlar	birlar
		1	1	
4	3	3	8	5
+	5	2	0	6
	9	5	4	5
			5	0

o'n minglar	minglar	yuzlar	o'nlar	birlar
9	8	7	6	5
	6	5	4	3
9	2	2	2	2

o'n minglar	minglar	yuzlar	o'nlar	birlar
		3	2	7
		1	0	9
	2	9	4	3
+	3	0	0	
	3	2	7	
	3	5	6	4
			4	3

$$\begin{array}{r}
 1206 \quad | \quad 9 \\
 - \quad 9 \quad \downarrow \\
 \hline
 30 \quad \downarrow \\
 - \quad 27 \quad \downarrow \\
 \hline
 36 \\
 - \quad 36 \\
 \hline
 0
 \end{array}$$



### Guruhlarda ishlaymiz: 1-3.

#### 1. Hisoblang.

a)  $65\,772 + 34\,228$

b)  $172\,338 + 327\,662$

c)  $8\,900\,307 + 1\,099\,693$

d)  $8\,364\,579 - 1\,635\,421$

e)  $1\,205\,620 - 1\,076\,799$

f)  $5\,645\,789 - 3\,214\,658$

g)  $669\,023 \times 7$

h)  $27\,613 \times 26$

i)  $9\,600\,696 \div 84$

j)  $11\,682\,000 \div 125$

2. Omborda 2 414 quti pomidor bor edi. Birinchi kuni 735, ikkinchi kuni 813 va uchinchi kuni esa 756 quti pomidor sotildi. Omborda necha quti pomidor qoldi? Agar har bir qutidagi pomidorlar og'irligi 18 kg bo'lsa, 3 kunda necha kilogramm pomidor sotilgan? Qaysi kunda kamroq pomidor sotilgan? Eng ko'pi-chi?



3. Ifodalarning qiymatini toping.

a)  $69 \div 23 + 45 \times (896 - 15 \times 32)$

b)  $788 - 414 \div 18 + 768 \div 12 \times 4$

c)  $54 \times 286 - 589 \div 19 + 48 + 658 - 98$

d)  $96 \times (4\,508 \div 98 + 3\,534 \div 38) - 156$



### Qiziqarli matematika: 4–8.

4. O'quvchi 65 000 so'mga ruchka va daftarlar sotib oldi. Bir dona daftarning narxi 2 000, ruchka esa 3 000 so'm turadi. O'quvchi nechta daftar va ruchka sotib olgan?

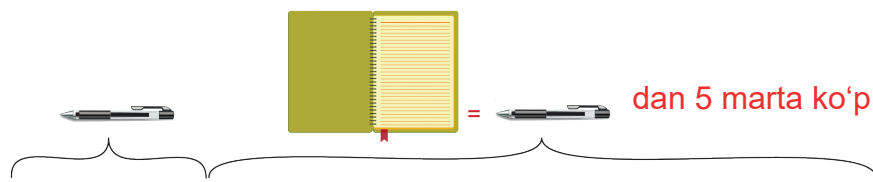

5. 2, 9, 3, 6 va 0 raqamlaridan foydalanib eng katta va eng kichik 5 xonali sonlarni hosil qiling. Hosil bo'lgan sonlarning kattasidan kichigini ayiring.

6. Mustafu 14 yoshda, uning 1 yoshli Iymona va 4 yoshli Soliha ismli singlisi bor. Necha yildan keyin Iymona va Solihaning yoshlari yig'indisi Mustafoning yoshiga teng bo'ladi?

7. Harflarga mos raqamlarni toping.

$$\begin{array}{r} 2 \text{ A } 3 \ 4 \\ 7 \ 3 \ \text{B} \\ + \ 6 \ \text{C} \ 7 \\ \hline 3 \ 4 \ 4 \ 9 \end{array}$$

$$\begin{array}{r} 8 \ 7 \ \text{D} \ 4 \ 3 \\ - \ 7 \ 9 \ 2 \ \text{E} \\ \hline 7 \ 9 \ 1 \ \text{F} \ 5 \end{array}$$

$$\begin{array}{r} \text{J} \ \text{K} \ \text{L} \\ \times \quad \quad 4 \\ \hline 9 \ 4 \ 0 \end{array}$$

$$\begin{array}{r} 2 \ 1 \ 5 \\ \times \quad \text{X} \ \text{Y} \\ \hline 8 \ 6 \ 0 \\ + \ 4 \ 3 \ 0 \\ \hline 5 \ 1 \ 6 \ 0 \end{array}$$

8. Fermada tovuq, echki va sigir bor. Barcha hayvonlarning boshi 19 ta, oyoqlari esa 56 ta. Fermada nechta tovuq bor?



### Mustahkamlash: 9–10.

9. Jadvalda bir hafta ichida futbol stadioniga tashrif buyurganlar soni keltirilgan. Berilgan ma'lumotlarni ko'rib chiqing va quyidagi savollarga javob bering.

Agar stadionga kirish chiptasi narxi 10 000 so'm bo'lsa, seshanba kuni qancha pul yig'ilgan?

Hafta davomida stadionga kelgan tomoshabinlarning umumiy soni nechta?

Shanba kuni chorshanbaga qaraganda nechta ko'p tomoshabin bor edi?

Kunlar	Tomoshabinlar soni
Dushanba	21 587
Seshanba	15 721
Chorshanba	16 040
Payshanba	13 674
Juma	22 876
Shanba	26 330
Yakshanba	25 889

10. 39 ni bo'lganda qoldiq 9 chiqadigan barcha natural sonlarning yig'indisini toping.



### Mustaqil ish: 11–12.

11. Harflarga mos raqamlarni toping.

$$\begin{array}{r} 50A9 \\ 245B \\ + C27 \\ \hline 7966 \end{array}$$

$$\begin{array}{r} 6D49E \\ - 81F5 \\ \hline G5347 \end{array}$$

$$\begin{array}{r} 224 \\ \times 3T \\ \hline 896 \\ + MN O \\ \hline NML6 \end{array}$$

$$\begin{array}{r} 23X \\ \times X4 \\ \hline Z32 \\ + 699 \\ \hline 7922 \end{array}$$

12. Bir hafta mobaynida uchta tumanda haydovchilardan qoidabuzarliklar uchun 23 875 500 so'm jarima undirildi. Birinchi tumanda 9 823 000, ikkinchisida 11 575 000 so'm jarima undirilgan bo'lsa, uchinchi tumanda qancha jarima undirilgan?

### TUB VA MURAKKAB SONLAR. EKUB VA EKUK



#### Eslaymiz!

1. Sonlarni tub ko'paytuvchilarga ajratishni tushuntira olasizmi?

- Tub sonlar    ● Murakkab sonlar

$$\begin{array}{c} 20 \\ \swarrow \quad \searrow \\ 2 \quad \times \quad 10 \\ \quad \swarrow \quad \searrow \\ \quad 2 \quad \times \quad 5 \end{array}$$

$$20 = 2 \times 2 \times 5$$

$$\begin{array}{c} 48 \\ \swarrow \quad \searrow \\ 2 \quad \times \quad 24 \\ \quad \swarrow \quad \searrow \\ \quad 2 \quad \times \quad 12 \\ \quad \quad \swarrow \quad \searrow \\ \quad \quad 2 \quad \times \quad 6 \\ \quad \quad \quad \swarrow \quad \searrow \\ \quad \quad \quad 2 \quad \times \quad 3 \end{array}$$

$$48 = 2 \times 2 \times 2 \times 2 \times 3$$

$$\begin{array}{c} 75 \\ \swarrow \quad \searrow \\ 3 \quad \times \quad 25 \\ \quad \swarrow \quad \searrow \\ \quad 5 \quad \times \quad 5 \end{array}$$

$$75 = 3 \times 5 \times 5$$

2. Nima uchun sonlarning EKUBi 1 ga teng bo'ldi?

$$\begin{array}{r|l} 20 & 2 \\ 10 & 2 \\ 5 & 5 \\ 1 & \end{array}$$

$$\begin{array}{r|l} 48 & 2 \\ 24 & 2 \\ 12 & 2 \\ 6 & 2 \\ 3 & 3 \\ 1 & \end{array}$$

$$\begin{array}{r|l} 75 & 3 \\ 25 & 3 \\ 5 & 5 \\ 1 & \end{array}$$

$$\text{EKUB}(20; 48; 75) = 1$$

$$\text{EKUK}(20; 48; 75) = 2 \times 2 \times 2 \times 2 \times 3 \times 3 \times 5 = 720$$



### Guruhlarda ishlaymiz: 1–7.

1. Sonning natural bo'luvchilarini toping: 48; 36; 69; 75; 79; 91.

2. Quyidagi sonlardan qaysi biri 2; 3; 4; 5; 6; 8; 9; 10; 11 ga qoldiqsiz bo'linadi?

32

12

58

40

55

3. Quyidagi sonlardan qaysilari 2 ga, 3 ga yoki 5 ga bo'linadi? Ular ichida bir vaqtda 2, 3 va 5 ga bo'linadigan sonlar bormi?

250

840

525

4686

480

4. Quyidagi sonlar orasidagi o'zaro tub sonlarni ajratib, yozing.

a) 25 dan 48 gacha

b) 28 dan 42 gacha

c) 58 dan 75 gacha

5. Hisoblang.

a) EKUB (15; 25; 37)

b) EKUK (8; 12; 20)

c) EKUK (60; 90; 30)

6. Maktab bo'yicha 6-sinfda 60 nafar qiz va 72 nafar o'g'il bola bor. Bolalar nechta guruhga bo'linsa, ular teng taqsimlanadi? Nechta guruh yaratishingiz mumkin? Har bir guruhda nechta qiz va o'g'il bola bo'ladi?

7. Davronda 12 ta, Rustamda esa 18 ta shokolad bor. Ularning har biri shokoladlarni do'stlari bilan baham ko'rdi. Agar Davron va Rustam bir xil miqdordagi shokolad berishsa, ularning har bir do'sti nechta shokolad oladi?



### Mustahkamlash: 8-9.

8. Quyidagi "ko'paytuvchilar daraxti"ni to'ldiring.

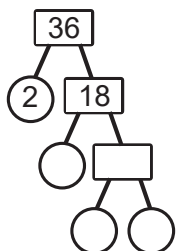

$$36 = \_ \times \_ \times \_ \times \_$$

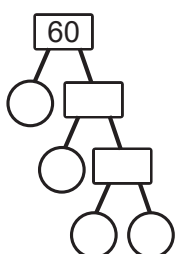

$$60 = \_ \times \_ \times \_ \times \_$$

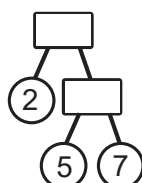

$$\_ = \_ \times \_ \times \_$$

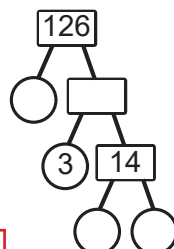

$$\_ = \_ \times \_ \times \_ \times \_$$

9. Shu usuldan foydalanib 18; 76; 55; 100; 69; 41 sonlarini ham tub ko'paytuvchilarga ajrating.



### Mustaqil ish: 10-12.

10. Quyidagi sonlardan qaysi biri 2; 3; 4; 5; 6; 8; 9; 10; 11 ga bo'linadi?

a) 698 247

b) 4 632

c) 9 030

d) 654 921

11. 64, 81, 128 sonlarini tub ko'paytuvchilarga ajrating.

12. Hisoblang:

a) EKUB (81; 54)

b) EKUK (16; 6)

## BIR XIL MAXRAJLI KASRLAR, O'NLI KASRLARNI QO'SHISH VA AYIRISH



## Eslaymiz!

1. Amallar qanday bajarilganini eslaymiz va natijalarni aytamiz.

## Qo'shish

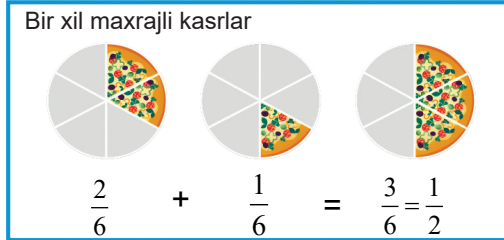

## Ayirish

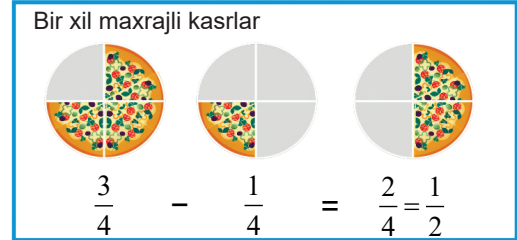

2. O'nli kasrlarni qo'shish va ayirish qanday amalga oshirilgan?

$$2,38 + 1,47 = 3,85$$

	2	,	3	8
+	1	,	4	7
	3	,	8	5

$$1,48 - 0,16 = 1,32$$

	1	,	4	8
-	0	,	1	6
	1	,	3	2



## Guruhlarda ishlaymiz: 1-8.

1. Hisoblang.

a)  $\frac{3}{8} + \frac{2}{8}$

b)  $\frac{3}{10} + \frac{5}{10}$

c)  $\frac{24}{50} + \frac{17}{50}$

d)  $\frac{38}{124} + \frac{45}{124}$

2. Ayirmalar nimaga teng? Natijalarni taqqoslang.

a)  $\frac{10}{12} - \frac{5}{12}$

b)  $\frac{7}{8} - \frac{5}{8}$

c)  $\frac{21}{37} - \frac{14}{37}$

d)  $\frac{51}{256} - \frac{39}{256}$

3. 1-probirkada  $\frac{5}{25}$  litr suv bor. Undan  $\frac{2}{25}$  litr suv 2-probirkaga quyildi. 1-probirkada qancha suv qolgan? Agar unga yana  $\frac{4}{25}$  litr suv quyilsa, probirkada qancha suv bo'ladi?

4. Ifodalarning qiymatini toping.

a)  $\frac{15}{29} - \left( \frac{27}{29} - \frac{22}{29} \right) + \frac{11}{29}$

b)  $\left( \frac{19}{92} - \frac{12}{92} + \frac{62}{92} \right) - \frac{43}{92}$

c)  $\left( \frac{43}{88} + \frac{37}{88} \right) - \left( \frac{76}{88} - \frac{52}{88} \right)$

d)  $\frac{43}{62} - \frac{26}{62} + \frac{34}{62} - \frac{19}{62} + \frac{23}{62}$

5. Barno texnologiya darsida ikki xil pishiriq tayyorladi. 1-pishiriq uchun 1,75 stakan, 2-pishiriq uchun 0,25 stakan shakar ishlatdi. Barno hammasi bo'lib qancha shakar ishlatgan?

6. O'rmon 33 km<sup>2</sup> masofaga yoyilgan edi. Yong'inlar va sanoat korxonolari tufayli u qisqarib, 16,5 km<sup>2</sup> bo'lib qoldi. O'rmon qancha qismga qisqargan? O'rmonlarni himoya qilish uchun qanday choralar ko'rish mumkin?

7. Hisoblang.

a)  $6\frac{2}{7} - 5\frac{1}{7}$       b)  $2\frac{4}{10} + 5\frac{5}{10}$       c)  $4\frac{7}{8} - 2\frac{4}{8}$       d)  $1\frac{2}{8} + 1\frac{1}{8}$

8. Hisoblang.

a)  $15,25 + 60,98 + 10,50$       b)  $19,405 + 20,210 + 8,100$   
c)  $143,210 - 89,025$       d)  $1001,002 - 975,350$



**Qiziqarli matematika: 9–10.**

9. Rasmdagi mantiqiy bog'liqlikni aniqlab, keyingi mos keluvchi shaklni toping.

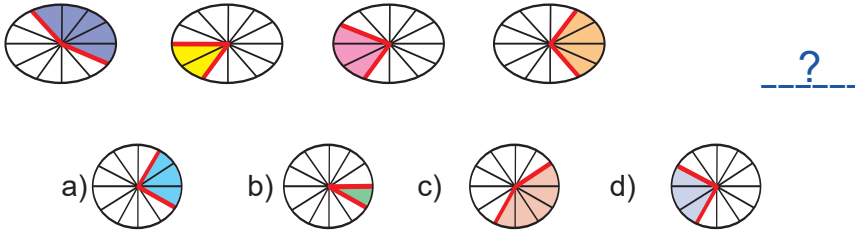

10. Berilgan kvadratni to'ldiring. Barcha satr va ustunlar yig'indisi 9,0 ga teng bo'lsin.

		3,6
1,8	3,0	



**Mustaqil ish: 11–13.**

11. Hisoblang.

a)  $\frac{17}{42} - \left(\frac{39}{42} - \frac{28}{42}\right) + \frac{23}{42}$       b)  $\left(\frac{48}{74} + \frac{17}{74} - \frac{26}{74}\right) - \frac{23}{74}$

12. Rasmda keltirilgan yo'lakni 2 metr kenglikdagi gilam bilan qoplash uchun gilamning uzunligi necha metr bo'lishi kerak?

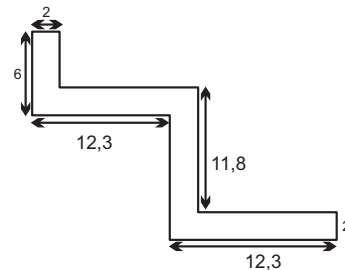

13. Hisoblang.

a)  $73,17 + 21,83 + 0,5$       b)  $21,75 + 17,25 - 0,17$   
c)  $75,140 + 24,860$       d)  $22,01 - 15,45$



Eslaymiz!

1. To'g'ri chiziqlar o'zaro qanday holatda joylashgan?

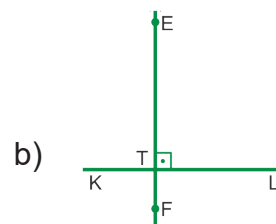

2. Qanday burchaklarni ko'ryapsiz? Ularni graduslarda o'lchay olamizmi?

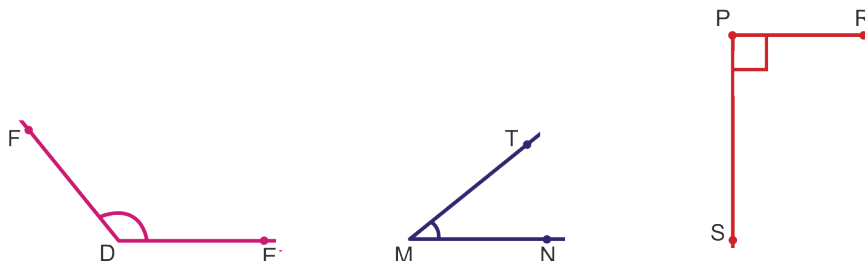

3. Yassi va fazoviy shakllarning farqi va elementlarini toping.

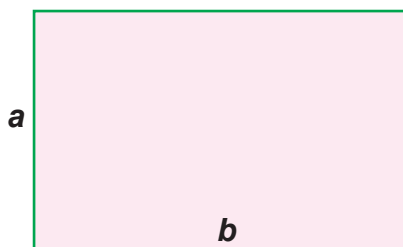

Perimetr:  
 $P = 2(a + b)$

Yuzi:  
 $S = ab$

Perimetr:  
 $P = 4a$

Yuzi:  
 $S = a^2$

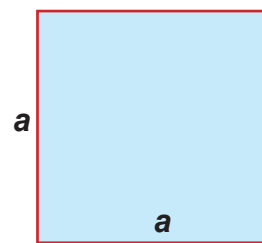

To'la sirti yuzi:  
 $S = 2(ab + bc + ac)$

Hajm:  
 $V = abc$

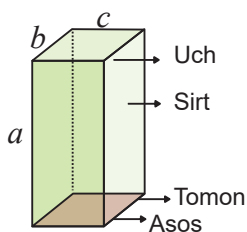

To'la sirti yuzi:  
 $S = 6a^2$

Hajm:  
 $V = a^3$

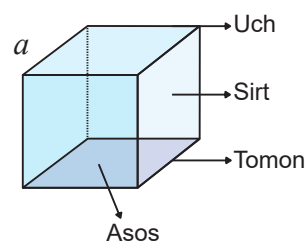

Gruhlarda ishlaymiz: 1-4.

1. Transportir yordamida burchaklarni o'lchang.

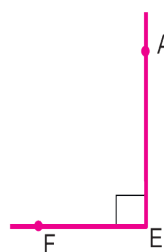
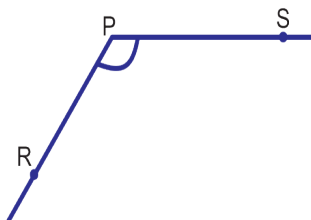
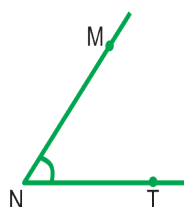

2. Parallel va perpendikulyar to'g'ri chiziqlarni aniqlang.

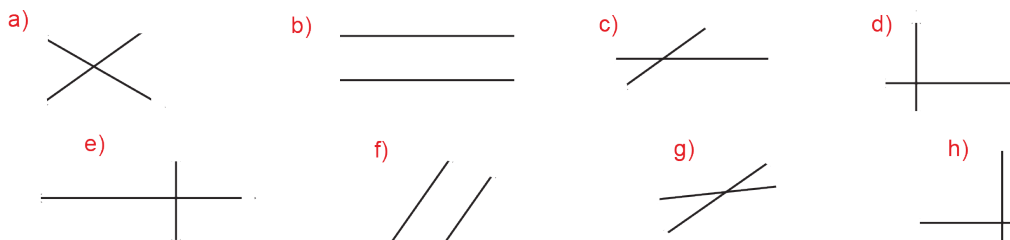

3. Chizg'ich va transportirdan foydalanib uchburchakning turi va burchaklarini toping.

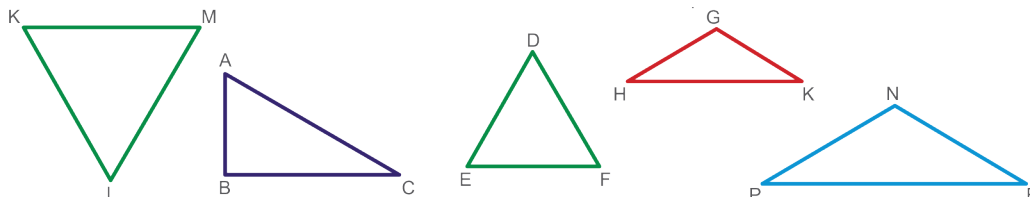

4. Shakllar yuzasini toping.

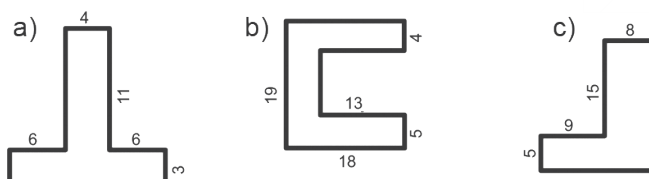

### Qiziqarli matematika: 5-6.

5. Uchburchakning bir tomoni ikkinchisidan 2 cm qisqa, uchinchi tomonidan 2 cm uzunroq. Uchburchak perimetri 27 cm ga teng bo'lsa, uning tomonlari uzunliklarini aniqlang.

6. 1-shakldagi kubdan nechta kichik kubchalarni olib tashlasak, 2-shakldagi jism hosil bo'ladi?

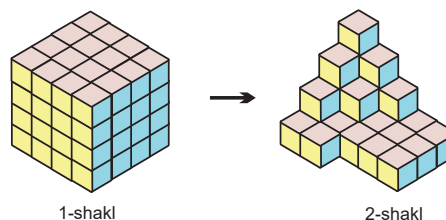

### Mustahkamlash: 7-10.

7. Chizg'ich yordamida to'g'ri to'rtburchak va kvadratlarning tomonini o'lchab, yuzini toping.

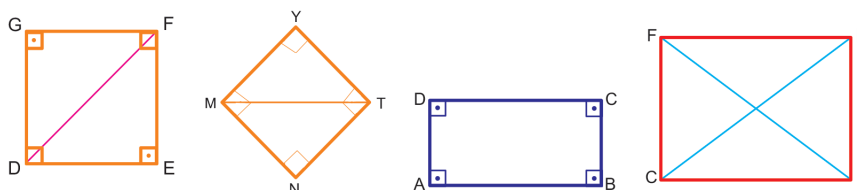

8. To'g'ri burchakli parallelepiped va kublarning to'la sirti yuzi va hajmini toping.

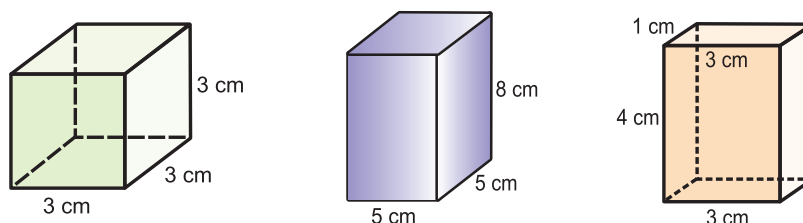

9. ABCD to'rtburchakning AB tomoni 45 cm, BC tomoni undan 23 mm uzun, CD tomoni BC tomonidan 1 cm 2 mm qisqa, AD tomoni esa CD tomonidan 56 mm uzun. ABCD to'rtburchakning perimetrini toping.

10. Munosabatlarni o'rnating.

a)  $4 \text{ ha} = \dots \text{ m}^2$

b)  $20 \text{ ha} = \dots \text{ m}^2$

c)  $5 \text{ ha} = \dots \text{ m}^2$

d)  $15 \text{ ha} = \dots \text{ m}^2$

e)  $1 \text{ km}^2 = \dots \text{ ha}$

f)  $15 \text{ km}^2 = \dots \text{ ha}$

g)  $1000 \text{ km}^2 = \dots \text{ ha}$

h)  $75\,000 \text{ m}^2 = \dots \text{ ha}$

i)  $250 \text{ km}^2 = \dots \text{ ha}$



**Mustaqil ish: 11–13.**

11. Shakllarning perimetri va yuzini toping.

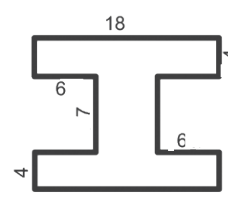
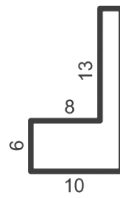
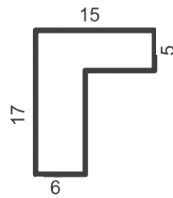

12. Fazoviy shakllarning to'la sirti yuzi va hajmini toping.

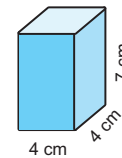
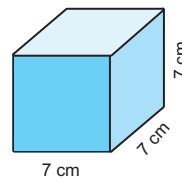
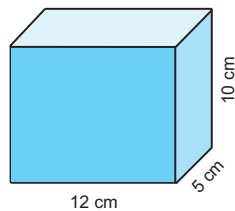

13. Siz o'yinchoq mashinani qaysi qutiga joylagan bo'lar edingiz?

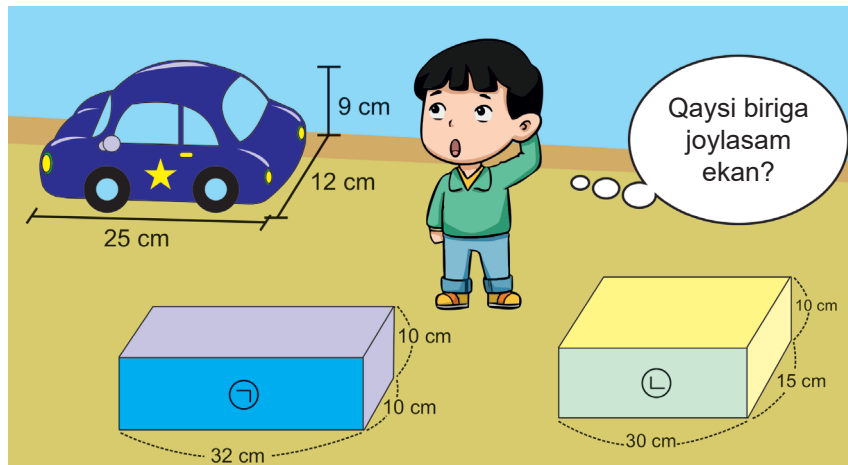



# I bob

## KASRLARNI QO'SHISH VA AYIRISH

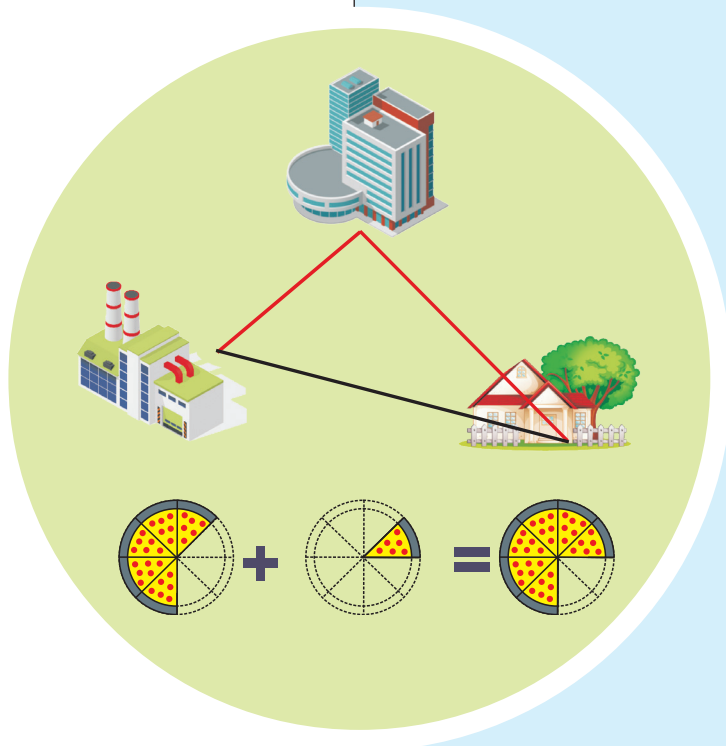

## TENG KASRLAR



## Eslaymiz!

Aylanalar qanday bo'laklarga bo'lingan?

Ularining qanday qismi bo'yalgan?

Aylanani bo'laklarga bo'lishni davom ettira olasizmi?

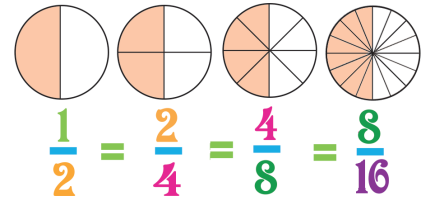

E'tibor berdingizmi, aylanalarning bo'yalgan sohalari teng.

$$\frac{1}{2} = \frac{2}{4} = \frac{4}{8} = \frac{8}{16}$$

(Arrows indicate multiplication by 2 between adjacent fractions: 1/2 to 2/4, 2/4 to 4/8, 4/8 to 8/16)

Demak,  $\frac{1}{2} = \frac{2}{4} = \frac{4}{8} = \frac{8}{16}$  kasrlar o'zaro teng.

! Kasrning surat va maxraji ayni bir natural songa ko'paytirilsa, berilgan kasrning qiymati o'zgarmaydi, avvalgi kasrga teng kasr hosil bo'ladi.

$$\frac{a}{b} = \frac{a \times n}{b \times n} \quad \text{bu yerda } a, b, n - \text{ natural sonlar.}$$



## Guruhlarda ishlaymiz: 1-4.

1. Bo'sh kataklarni to'ldiring.

$$\frac{2}{3} = \frac{4}{6} = \frac{\square}{9} = \frac{8}{\square} = \frac{\square}{\square} = \dots$$

$$\frac{3}{4} = \frac{\square}{\square} = \frac{\square}{\square} = \frac{\square}{\square} = \frac{\square}{\square} = \dots$$

2. Noma'lum sonlarni toping.

a)  $\frac{3}{4} = \frac{x}{20}$

b)  $\frac{2}{3} = \frac{8}{x}$

c)  $\frac{5}{9} = \frac{x}{36}$

d)  $\frac{9}{11} = \frac{45}{x}$

3. Bo'yalgan sohalarni teng kasrlarda ifodalang.

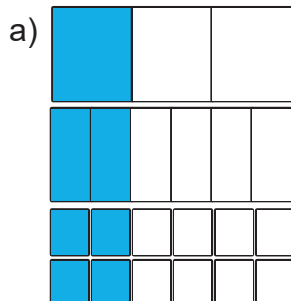

b)

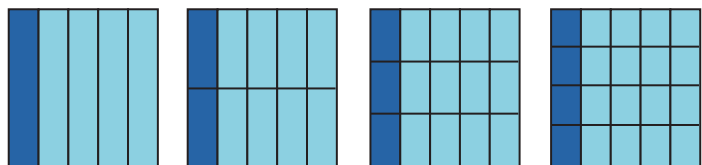

4. Ikki ta bir xil kattalikdagi pishiriqning biri 36 bo'lakka, ikkinchisi 72 bo'lakka bo'linib, likoplarga teng miqdorda solindi. Pishiriq bo'laklari likoplarga teng taqsimlanishi uchun har biridan nechtadan olish kerak?



### Qiziqarli matematika: 5-7.

5. Yulduzcha o'rniga mos sonni toping.

$$a) \frac{5}{7} = \frac{*}{14}$$

$$b) \frac{1}{3} = \frac{8}{*}$$

$$c) \frac{6}{7} = \frac{*}{21}$$

$$d) \frac{3}{10} = \frac{15}{*}$$

6. Surati  $\frac{5}{9}$  kasrning suratidan katta, ammo shu kasrga teng to'rtta kasr yozing.

7. Maxraji  $\frac{2}{7}$  kasrning maxrajidan katta, ammo shu kasrga teng to'rtta kasr yozing.



### Mustahkamlash: 8-12.

8. Teng kasrlarni ifoda etuvchi mosliklarni toping.

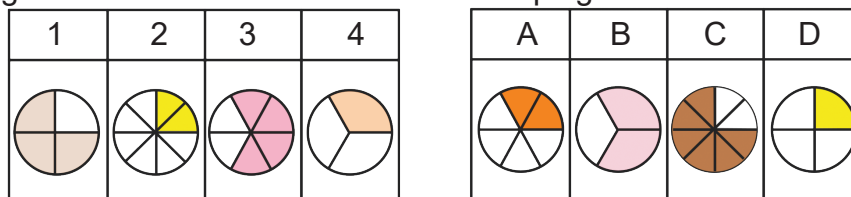

9. Kasrning asosiy xossasidan foydalanib quyidagi kasrlarga teng bo'lgan uchtdan kasr yozing.

$$a) \frac{2}{5}$$

$$b) \frac{4}{7}$$

$$c) \frac{5}{8}$$

$$d) \frac{3}{4}$$

10.  $\frac{3}{5}$  kasrni maxraji 15; 25; 35; 55 va 65 ga teng bo'lgan kasr shaklida yozing.

11. Namuna asosida bo'sh kataklarni to'ldiring va kasrlarning tengligini tekshiring.

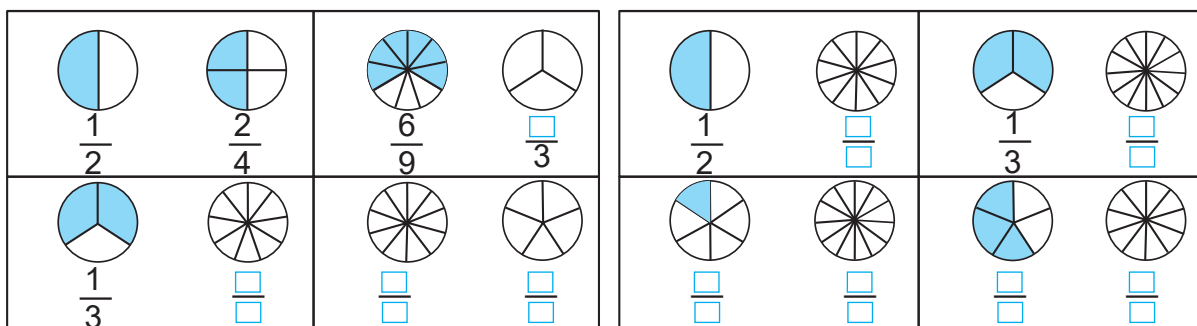

12\*. Tenglamani yeching.

$$a) \frac{4}{5} = \frac{16}{x+7}$$

$$b) \frac{10}{13} = \frac{x+8}{26}$$

$$c) \frac{11}{15} = \frac{33}{29+x}$$

$$d) \frac{14}{17} = \frac{2x+12}{51}$$



### Mustaqil ish: 13-15.

13. Kasrning asosiy xossasidan foydalanib quyidagi kasrlarga teng bo'lgan uchtdan kasr yozing.

$$a) \frac{6}{7}$$

$$b) \frac{4}{11}$$

$$c) \frac{8}{9}$$

$$d) \frac{3}{13}$$

14. Bo'yalgan sohalarni teng kasrlarda ifodalang.

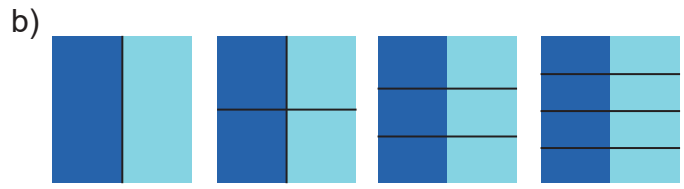
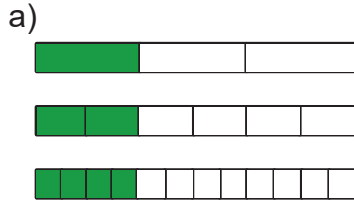

15. a)  $\frac{7}{8}$  kasrga teng 5 ta kasr yozing; b)  $\frac{7}{10}$  kasrga teng 5 ta kasr yozing.

### KASRLARNI QISQARTIRISH

Shakl bo'laklarini solishtiramiz.

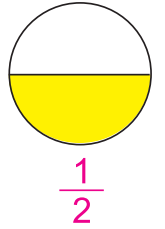
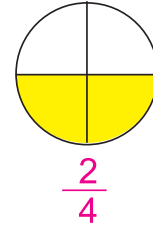
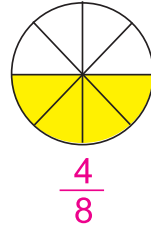
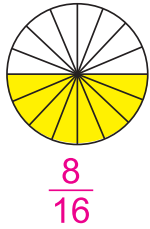

Rasmdagi shaklning  $\frac{8}{16}$ ,  $\frac{4}{8}$ ,  $\frac{2}{4}$ ,  $\frac{1}{2}$  bo'laklari teng. Demak, bu kasrlar o'zaro teng.

Ular qanday hosil bo'ldi?

$$\frac{8}{16} \xrightarrow{\div 2} \frac{4}{8} \xrightarrow{\div 2} \frac{2}{4} \xrightarrow{\div 2} \frac{1}{2}$$

! Kasrning surati va maxrajini 1 dan farqli umumiy bo'luvchiga bo'lish **kasrni qisqartirish** deyiladi. Bunda kasrning qiymati o'zgarmaydi, avvalgi kasrga teng kasr hosil bo'ladi.

$$\frac{a \div n}{b \div n} = \frac{a}{b} \quad \text{bu yerda } n - \text{umumiy bo'luvchi.}$$



Guruhlarda ishlaymiz: 1-4.

1. Umumiy bo'luvchilar nimaga teng?

a)  $\frac{4}{12} = \frac{\square}{\square}$

b)  $\frac{5}{25} = \frac{\square}{\square}$

c)  $\frac{12}{36} = \frac{\square}{\square}$

d)  $\frac{14}{63} = \frac{\square}{\square}$

e)  $\frac{18}{108} = \frac{\square}{\square}$

f)  $\frac{50}{225} = \frac{\square}{\square}$

g)  $\frac{48}{576} = \frac{\square}{\square}$

2. Kasrlarni qisqartirish qanday amalga oshirilgan?

$$\frac{168}{294} = \frac{168 \div 2}{294 \div 2} = \frac{84}{147} = \frac{84 \div 3}{147 \div 3} = \frac{28}{49} = \frac{28 \div 7}{49 \div 7} = \frac{4}{7}$$

a)  $\frac{64}{88}$

b)  $\frac{99}{110}$

c)  $\frac{222}{234}$

Berilgan kasrlarni namuna asosida qisqartiring.

3. Bolalarning natijalarini taqqoslang.

Alisher basketbol to'pini 18 marta otdi va 8 marta to'rga tushirdi.

Adiba basketbol to'pini 9 marta otdi va 4 marta to'rga tushirdi.

4. Kasrlarni qisqartiring.

a) 2 ga:  $\frac{4}{6}$ ;  $\frac{8}{10}$ ;  $\frac{14}{26}$ ;  $\frac{34}{46}$

b) 3 ga:  $\frac{3}{9}$ ;  $\frac{12}{15}$ ;  $\frac{18}{21}$ ;  $\frac{39}{48}$



**Mustahkamlash: 5-9.**

5. Bo'yalgan sohalarga mos teng kasrlar hosil qiling.

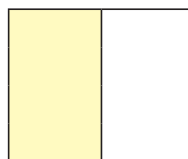
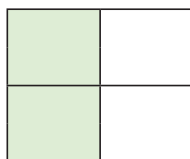
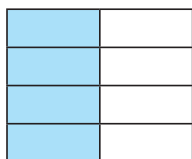

6. Qisqartiring.

a) 4 ga:  $\frac{4}{8}$ ;  $\frac{12}{16}$ ;  $\frac{20}{24}$ ;  $\frac{28}{32}$ ;  $\frac{36}{40}$

b) 6 ga:  $\frac{18}{30}$ ;  $\frac{42}{48}$ ;  $\frac{54}{66}$ ;  $\frac{90}{126}$

7. Umumiy bo'luvchilarni toping.

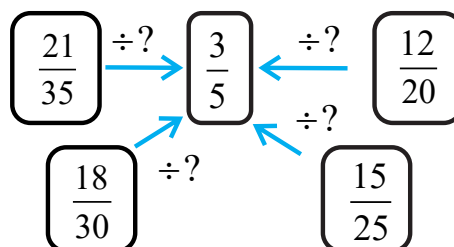

8. Kasrlardan qaysi biri  $\frac{48}{60}$  ga va qaysi biri  $\frac{36}{84}$  ga teng?

1	2	3	4	5	6	7	8	9	10	11	12
$\frac{3}{7}$	$\frac{8}{10}$	$\frac{12}{10}$	$\frac{24}{30}$	$\frac{12}{28}$	$\frac{12}{15}$	$\frac{9}{15}$	$\frac{16}{20}$	$\frac{9}{21}$	$\frac{6}{14}$	$\frac{18}{42}$	$\frac{4}{5}$

9\*. Tenglamalarni yeching.

a)  $\frac{28}{42} = \frac{x+1}{6}$

b)  $\frac{55}{75} = \frac{11}{x+8}$

c)  $\frac{63}{84} = \frac{3}{8-x}$

d)  $\frac{120}{140} = \frac{9-x}{7}$



**Qiziqarli matematika: 10-12.**

10. Yulduzcha o'rniga mos sonni qo'ying.

a)  $\frac{18}{28} = \frac{*}{14}$

b)  $\frac{35}{45} = \frac{7}{*}$

c)  $\frac{49}{56} = \frac{*}{8}$

d)  $\frac{51}{68} = \frac{*}{4}$

e)  $\frac{220}{440} = \frac{1}{*}$

f)  $\frac{450}{550} = \frac{*}{11}$

11. Noma'lumlarni toping.

a)  $\frac{40}{60} = \frac{?}{?} = \frac{?}{15} = \frac{?}{?}$

b)  $\frac{2}{3} = \frac{?}{?} = \frac{?}{?} = \frac{?}{?} = \frac{?}{?}$

12.  $\frac{20-n}{24}$  -  $n$  ning qanday natural qiymatida:

a) qisqaradigan kasr hosil bo'ladi?

b) qisqarmaydigan kasr hosil bo'ladi?



**Mustaqil ish: 13-15.**

13. Kasrlarni qisqartiring.

a)  $\frac{15}{20}$

b)  $\frac{22}{24}$

c)  $\frac{18}{90}$

d)  $\frac{30}{54}$

14. Bo'yalgan sohalarni kasrlarda ifodalang. Xulosangizni ayting.

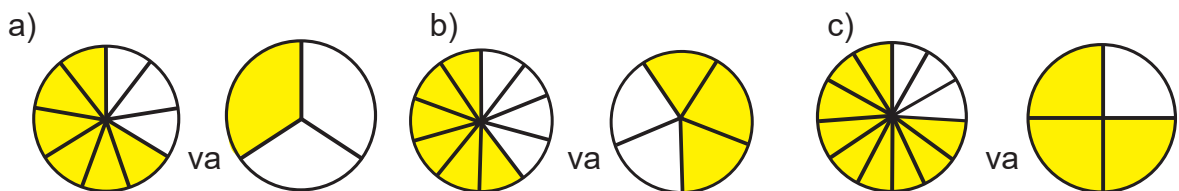

15. a)  $\frac{6}{8}; \frac{12}{22}; \frac{30}{38}; \frac{42}{58}$  kasrlarni 2 ga; b)  $\frac{6}{9}; \frac{15}{27}; \frac{21}{39}; \frac{51}{60}$  kasrlarni 3 ga qisqartiring.

**KASRLARNI UMUMIY MAXRAJGA KELTIRISH**



**Eslaymiz!**

Sonlarning eng kichik umumiy karralisi (EKUK) qanday topilgan?

18	2	
9	3	
3	3	
1		

$18 = 2 \times 3 \times 3$

24	2	
12	2	
6	2	
3	3	
1		

$24 = 2 \times 2 \times 2 \times 3$

$EKUK (18; 24) = 2^3 \times 3^2 = 8 \times 9 = 72.$

Ikkita o'zaro tub sonning eng kichik umumiy karralisi shu sonlarning ko'paytmasiga teng.

!  $\frac{1}{18}$  va  $\frac{1}{24}$  kasrlarni umumiy maxrajga keltiramiz.

- EKUK (18; 24) = 72
- Topilgan EKUKni maxrajlariga bo'lamiz:  $72 \div 18 = 4$ ,  $72 \div 24 = 3$ .
- Kasrning asosiy xossasidan foydalanamiz:

$$\frac{1}{18} = \frac{1 \times 4}{18 \times 4} = \frac{4}{72} \qquad \frac{1}{24} = \frac{1 \times 3}{24 \times 3} = \frac{3}{72}$$



### Guruhlarda ishlaymiz: 1–5.

1. Kasrlarni umumiy maxrajga keltiring.

a)  $\left(\frac{4}{25}; \frac{3}{10}\right)$       b)  $\left(\frac{1}{6}; \frac{1}{9}\right)$       c)  $\left(\frac{3}{8}; \frac{1}{9}\right)$       d)  $\left(\frac{3}{10}; \frac{3}{4}\right)$

2. Bo'sh kataklarni to'ldiring.

$$\left(\frac{2}{5}; \frac{5}{6}\right) \rightarrow \left(\frac{\square}{30}; \frac{\square}{30}\right) \qquad \left(\frac{1}{4}; \frac{5}{7}\right) \rightarrow \left(\frac{\square}{28}; \frac{\square}{28}\right)$$

3.  $\left(\frac{5}{8}; \frac{7}{12}\right)$  kasrlarni umumiy maxrajga keltiring.

$$\frac{5}{8} = \frac{5 \times \square}{8 \times \square} = \frac{\square}{\square} \qquad \frac{7}{12} = \frac{7 \times \square}{12 \times \square} = \frac{\square}{\square} \qquad \left(\frac{\square}{\square}; \frac{\square}{\square}\right)$$

! Kasrlarning maxrajlari o'zaro tub sonlar bo'lsa, bu sonlarning ko'paytmasi umumiy maxraj bo'ladi.

$\left(\frac{4}{7}; \frac{3}{8}\right)$  kasrlarning maxraji o'zaro tub sonlar. Umumiy maxraj:  $7 \times 8 = 56$ .

$$\frac{4}{7} = \frac{4 \times 8}{7 \times 8} = \frac{32}{56} \qquad \frac{3}{8} = \frac{3 \times 7}{8 \times 7} = \frac{21}{56}$$

4. So'roq belgisi o'rniga mos keladigan sonni toping.

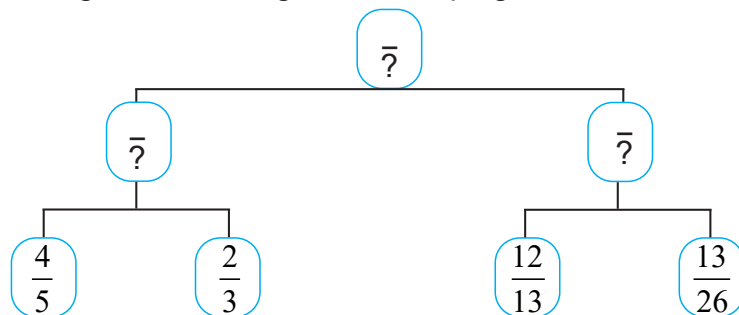

5. Kasrlarni umumiy maxrajga keltiring.

a)  $\left(\frac{4}{7}; \frac{7}{8}\right)$       b)  $\left(\frac{3}{11}; \frac{8}{13}\right)$       c)  $\left(\frac{4}{17}; \frac{1}{33}\right)$       d)  $\left(\frac{2}{21}; \frac{3}{25}\right)$



### Mustahkamlash: 6–11.

6. Kasrlarni qisqartiring, so'ngra umumiy maxrajga keltiring.

a)  $\left(\frac{3}{9}; \frac{5}{25}\right)$       b)  $\left(\frac{4}{8}; \frac{3}{6}\right)$       c)  $\left(\frac{16}{128}; \frac{25}{225}\right)$       d)  $\left(\frac{21}{98}; \frac{20}{84}\right)$

7. Sonlarni umumiy maxrajga keltiring.

$$\left(\frac{1}{2}; \frac{2}{5}\right) \Rightarrow \left(\frac{1 \times 5}{2 \times 5}; \frac{2 \times 2}{5 \times 2}\right) \Rightarrow \left(\frac{\square}{10}; \frac{\square}{10}\right)$$

a)  $\left(\frac{3}{4}; \frac{5}{6}\right)$       b)  $\left(\frac{2}{5}; \frac{7}{10}\right)$       c)  $\left(\frac{2}{9}; \frac{5}{6}\right)$       d)  $\left(\frac{7}{8}; \frac{1}{6}\right)$

8. Aralash sonlarni bir xil maxrajga keltiring.

$$\left(1\frac{1}{2}; 1\frac{3}{5}\right) \Rightarrow \left(1\frac{1 \times 5}{2 \times 5}; 1\frac{2 \times 2}{5 \times 2}\right) \Rightarrow \left(1\frac{5}{10}; 1\frac{6}{10}\right)$$

a)  $\left(1\frac{3}{5}; 1\frac{13}{25}\right)$       b)  $\left(2\frac{7}{10}; 3\frac{3}{4}\right)$       c)  $\left(3\frac{9}{20}; 1\frac{3}{8}\right)$       d)  $\left(3\frac{3}{8}; 4\frac{9}{10}\right)$

9. Kasrlar maxrajini 48 ga keltiring.  $\frac{1}{3}; \frac{1}{4}; \frac{1}{6}; \frac{1}{8}; \frac{1}{12}; \frac{1}{16}; \frac{1}{24}$ .

10. Umumiy maxraj toping.

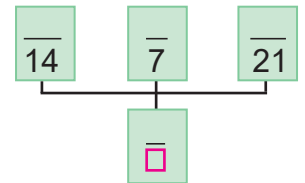
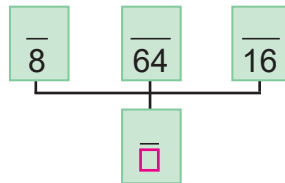
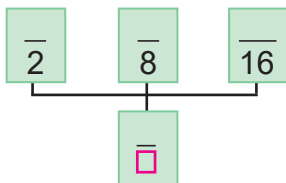

11. Berilgan barcha sonlar uchun umumiy maxraj toping.

$$\left[ \frac{1}{4} \quad 0,9 \quad \frac{4}{5} \quad 1,3 \right]$$



### Mustaqil ish: 12–13.

12. Kasrlarni umumiy maxrajga keltiring.

a)  $\left(\frac{4}{9}; \frac{9}{27}\right)$       b)  $\left(\frac{7}{8}; \frac{5}{6}\right)$       c)  $\left(\frac{1}{13}; \frac{9}{39}\right)$       d)  $\left(\frac{35}{50}; \frac{64}{80}\right)$       e)  $\left(\frac{14}{20}; \frac{35}{50}\right)$

13. Kasrlarni qisqartiring, so'ngra umumiy maxrajga keltiring.

a)  $\left(\frac{12}{108}; \frac{70}{180}\right)$       b)  $\left(\frac{14}{35}; \frac{20}{45}\right)$       c)  $\left(\frac{8}{64}; \frac{8}{40}\right)$       d)  $\left(\frac{14}{21}; \frac{30}{90}\right)$



## HAR XIL MAXRAJLI KASRLARNI TAQQOSLASH



Eslaymiz!

Kasrlar qanday taqqoslangan? Javobingizni tushuntiring.

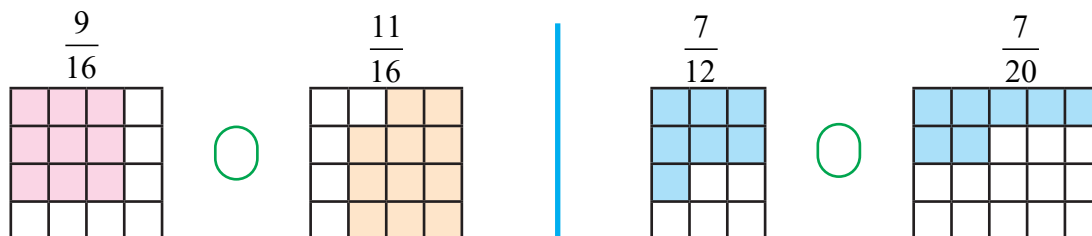

Agar kasrlarning maxrajlari har xil bo'lsa, taqqoslash qanday bajariladi?

## 1-usul

• Har xil maxrajli kasrlarni taqqoslash uchun ular umumiy maxrajga keltiriladi va bir xil maxrajli kasrlarni taqqoslash qoidasiga rioya qilinadi.

$$\frac{1}{4} \text{ va } \frac{3}{10} \rightarrow \frac{1 \times 5}{4 \times 5} \text{ va } \frac{3 \times 2}{10 \times 2} \rightarrow \frac{5}{20} < \frac{6}{20} \rightarrow \frac{1}{4} < \frac{3}{10}$$

## 2-usul

• Agar  $ad > bc$  bo'lsa,  $\frac{a}{b} > \frac{c}{d}$  bo'ladi;  $a, b, c, d$  – natural sonlar.

$$\frac{3}{4} > \frac{5}{9}, \text{ chunki } 3 \times 9 > 4 \times 5, \text{ ya'ni } 27 > 20.$$

• Agar  $ad < bc$  bo'lsa,  $\frac{a}{b} < \frac{c}{d}$  bo'ladi;  $a, b, c, d$  – natural sonlar.

$$\frac{7}{8} < \frac{11}{12}, \text{ chunki } 7 \times 12 < 8 \times 11, \text{ ya'ni } 84 < 88.$$

• Agar  $ad = bc$  bo'lsa,  $\frac{a}{b} = \frac{c}{d}$  bo'ladi;  $a, b, c, d$  – natural sonlar.

$$\frac{6}{51} = \frac{2}{17}, \text{ chunki } 6 \times 17 = 51 \times 2, \text{ ya'ni } 102 = 102.$$



Guruhlarda ishlaymiz: 1–2.

1. Modellarga mos kasrlarni taqqoslang.

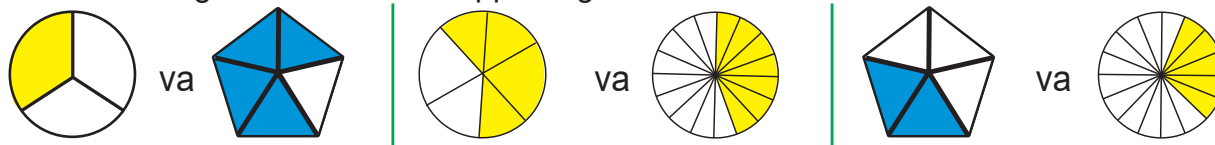

2. Kasrlarni taqqoslang.

$$\left(\frac{3}{4}; \frac{5}{6}\right) \Rightarrow \left(\frac{\square}{\square}; \frac{\square}{\square}\right) \Rightarrow \frac{3}{4} \circ \frac{5}{6} \quad \left(\frac{5}{6}; \frac{2}{3}\right) \Rightarrow \left(\frac{\square}{\square}; \frac{\square}{\square}\right) \Rightarrow \frac{5}{6} \circ \frac{2}{3}$$

$$\left(\frac{3}{4}; \frac{2}{3}\right) \Rightarrow \left(\frac{\square}{\square}; \frac{\square}{\square}\right) \Rightarrow \frac{3}{4} \circ \frac{2}{3}$$

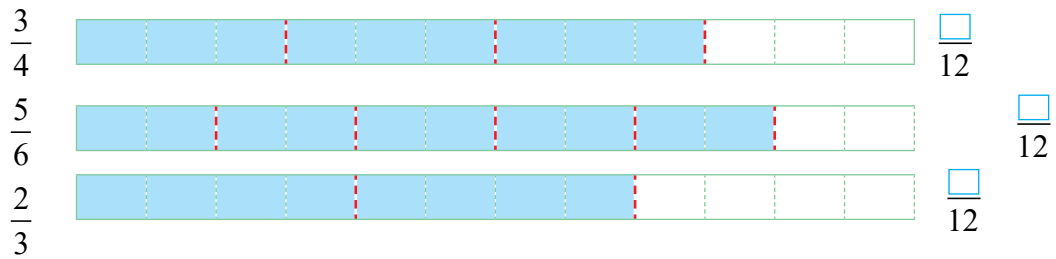

### Mustahkamlash: 3–8.

3. Kasrlar o'sib borish tartibida joylashganmi?  $\frac{4}{5}$   $\frac{16}{20}$   $\frac{24}{30}$   $\frac{12}{10}$   $\frac{8}{10}$   $\frac{9}{15}$
4. Kasrlar kamayib borish tartibida joylashganmi?  $\frac{3}{7}$   $\frac{12}{28}$   $\frac{9}{21}$   $\frac{6}{14}$   $\frac{18}{42}$
5. Modellarga mos kasrlarni taqqoslang.



6. Tengsizlikni qanoatlantiruvchi barcha  $x$  larni toping:  $\frac{7}{17} > \frac{x}{17}$
7. Umida maktabga borish uchun  $\frac{5}{12}$ , Ma'mura  $\frac{1}{3}$  soat sarflaydi. Qaysi biri maktabga tezroq yetib boradi?
8. Kasrlarni taqqoslang.

- a)  $\frac{61}{23}$  va  $\frac{9}{23}$       b)  $\frac{29}{58}$  va  $\frac{31}{58}$       c)  $\frac{17}{100}$  va  $\frac{21}{100}$       d)  $\frac{17}{40}$  va  $\frac{17}{45}$
- e)  $\frac{9}{4}$  va  $\frac{9}{2}$       f)  $\frac{3}{98}$  va  $\frac{3}{94}$       g) 1 va  $\frac{11}{14}$       h) 1 va  $\frac{28}{25}$
- i) 1 va  $\frac{68}{68}$       j)  $\frac{22}{22}$  va  $\frac{4}{4}$       k)  $\frac{27}{28}$  va  $\frac{28}{27}$       l)  $\frac{7}{6}$  va  $\frac{57}{59}$



### Mustaqil ish: 9.

9. Kasrlarni taqqoslang.
- a)  $\frac{7}{9}$  va  $\frac{11}{27}$       b)  $\frac{3}{40}$  va  $\frac{11}{20}$       c)  $\frac{3}{5}$  va  $\frac{5}{7}$       d)  $\frac{2}{3}$  va  $\frac{4}{15}$
- e)  $\frac{2}{7}$  va  $\frac{4}{15}$       f)  $\frac{11}{12}$  va  $\frac{13}{16}$       g)  $\frac{11}{12}$  va  $\frac{13}{14}$       h)  $\frac{22}{23}$  va  $\frac{44}{46}$

## HAR XIL MAXRAJLI KASRLARNI QO'SHISH



## Eslaymiz!

Qo'shish qanday bajarilgan?

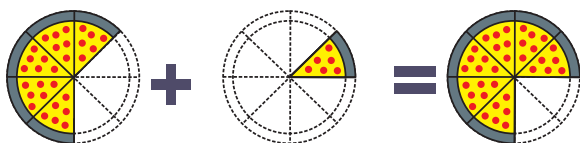

$$\frac{5}{8} + \frac{1}{8} = \frac{6}{8}$$

$$\frac{a}{b} + \frac{c}{b} = \frac{a+c}{b}$$

Agar kasrlarning maxraji har xil bo'lsa, qo'shish qanday bajariladi?

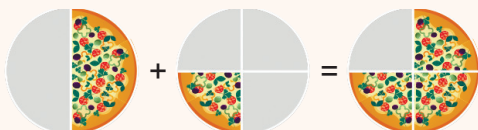

$$\frac{1}{2} + \frac{1}{4} = \frac{3}{4}$$

! Har xil maxrajli kasrlarni qo'shish uchun berilgan kasrlar bir xil maxrajga keltiriladi, so'ngra bir xil maxrajli kasrlarni qo'shish qoidasiga rioya qilinadi.

$$\frac{1}{2} + \frac{1}{4} = ? \quad \Rightarrow \quad \frac{1 \times 2}{2 \times 2} + \frac{1}{4}$$

$$\frac{2}{9} + \frac{1}{6} = ? \quad \Rightarrow \quad \frac{2 \times 2}{9 \times 2} + \frac{1 \times 3}{6 \times 3}$$

$$\Rightarrow \frac{2}{4} + \frac{1}{4} = \frac{2+1}{4} = \frac{3}{4}$$

↑      ↑  
bir xil

$$\Rightarrow \frac{4}{18} + \frac{3}{18} = \frac{4+3}{18} = \frac{7}{18}$$

↑      ↑  
bir xil



## Guruhlarda ishlaymiz: 1-4.

1. Kasrlarni qo'shing.

a)  $\frac{2}{25} + \frac{3}{5}$

b)  $\frac{4}{9} + \frac{1}{3}$

c)  $\frac{5}{7} + \frac{3}{14}$

d)  $\frac{7}{12} + \frac{5}{18}$

2. Hisoblang.

a)  $\frac{1}{2} + \frac{3}{4} + \frac{5}{8}$

b)  $\frac{3}{5} + \frac{7}{10} + \frac{2}{15}$

c)  $\frac{4}{9} + \frac{2}{3} + \frac{1}{6}$

d)  $\frac{5}{7} + \frac{1}{2} + \frac{3}{14}$

3. Toshkent va Farg'onadan bir vaqtda bir-biriga qarab ikkita avtomobil yo'lga chiqdi. Ulardan biri ma'lum vaqtda yo'lning  $\frac{1}{5}$  qismini, ikkinchisi esa  $\frac{7}{40}$  qismini bosib o'tdi. Ular birgalikda jami yo'lning qanday qismini bosib o'tgan?

4. Bo'yalgan sohalar asosida kasrlarni qo'shing.

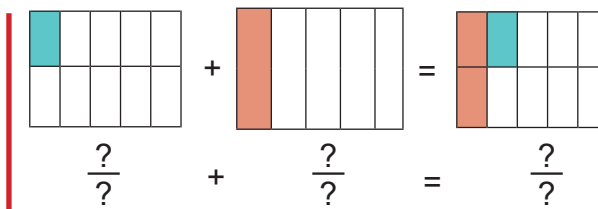
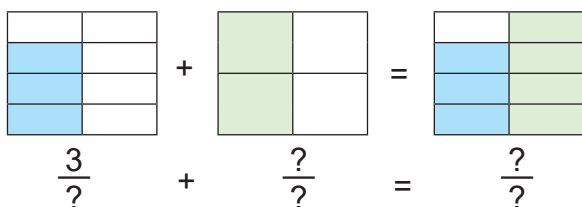

Maxraji o'zaro tub sonlar bo'lgan kasrlarni qo'shish.

$$\frac{2}{3} + \frac{1}{4} = \frac{2 \times 4 + 1 \times 3}{3 \times 4} = \frac{8 + 3}{12} = \frac{11}{12}$$



Guruhlarda ishlaymiz: 5-7.

5. Hisoblang.

a)  $\frac{3}{5} + \frac{2}{7}$

b)  $\frac{3}{4} + \frac{1}{7}$

c)  $\frac{4}{9} + \frac{2}{5}$

d)  $\frac{5}{11} + \frac{2}{9}$

6. Hisoblang.

a)  $\frac{1}{3} + \frac{1}{4} + \frac{1}{5}$

b)  $\frac{1}{5} + \frac{1}{6} + \frac{1}{7}$

c)  $\frac{2}{3} + \frac{3}{5} + \frac{1}{2}$

d)  $\frac{5}{6} + \frac{4}{7} + \frac{4}{5}$

7. Jadvalni to'ldiring.

+	$\frac{1}{2}$	$\frac{3}{5}$	$\frac{1}{6}$	$\frac{3}{10}$	$\frac{5}{8}$
$\frac{2}{3}$					
$\frac{1}{5}$					
$\frac{3}{4}$					



Mustahkamlash: 8-14.

8. Hisoblang.

a)  $\frac{1}{2} + \frac{1}{4}$

b)  $\frac{2}{5} + \frac{3}{10}$

c)  $\frac{3}{16} + \frac{1}{2}$

d)  $\frac{5}{9} + \frac{1}{3}$

e)  $\frac{3}{4} + \frac{1}{6}$

f)  $\frac{5}{9} + \frac{7}{12}$

g)  $\frac{3}{10} + \frac{2}{15}$

h)  $\frac{11}{20} + \frac{2}{15}$

9. Uchburchakning tomonlari  $\frac{2}{7}$  m,  $\frac{5}{21}$  m va  $\frac{3}{14}$  m ga teng. Shu uchburchakning perimetrini toping.

10. O'ngdagi rasmdan foydalanib hisoblang.

$\frac{\text{ko'k rang}}{\text{qizil rang}} + \frac{\text{sariq rang}}{\text{jami rang}}$



11\*. Tenglamani yeching (*ayirish amalidan foydalanmang*).

$$a) x + \frac{2}{5} = \frac{11}{15}$$

$$b) \frac{3}{4} + x = \frac{7}{8}$$

$$c) \frac{4}{9} + x = \frac{17}{27}$$

$$d) x + \frac{5}{11} = \frac{19}{22}$$

12\*. A, B, C larni toping va ularni taqqoslang.

$$a) \frac{2}{15} + \frac{3}{10} + \frac{A}{30} = \frac{2}{3}$$

$$b) \frac{1}{4} + \frac{B}{9} + \frac{7}{36} = \frac{2}{3}$$

$$c) \frac{C}{6} + \frac{17}{60} + \frac{13}{60} = \frac{2}{3}$$

13. Bo'sh kataklarni to'ldiring.

$$\frac{2}{5} + \frac{7}{15} = \frac{2 \times \square}{5 \times \square} + \frac{7}{15} = \frac{\square}{15} + \frac{7}{15} = \frac{\square}{15} \quad \frac{2}{9} + \frac{11}{12} = \frac{2 \times \square}{9 \times \square} + \frac{11 \times \square}{12 \times \square} = \frac{\square}{36} + \frac{\square}{36} = \frac{\square}{36} = \frac{\square}{\square}$$

14. Azamat  $\frac{1}{5}$  kg olma,  $\frac{1}{8}$  kg nok,  $\frac{1}{10}$  kg shakar va  $\frac{9}{10}$  kg suvni aralashtirib, o'ziga ichimlik tayyorladi. Azamat tayyorlagan ichimlikning massasini toping.



### Qiziqarli matematika: 15.

15. Yulduzcha o'rnidagi sonni toping.

$$a) \frac{*}{15} + \frac{2}{3} = \frac{14}{15}$$

$$b) \frac{5}{6} + \frac{*}{18} = \frac{17}{18}$$

$$c) \frac{11}{18} + \frac{*}{36} = \frac{31}{36}$$



### Mustaqil ish: 16-19.

16. Modellar asosida qo'shing.

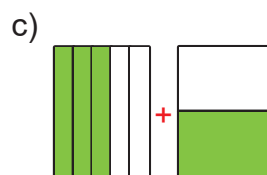
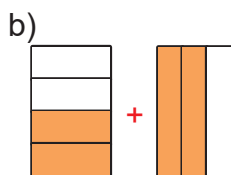
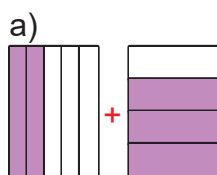

17. Kasrlarni qo'shing.

$$a) \frac{3}{10} + \frac{7}{15}$$

$$b) \frac{5}{8} + \frac{7}{12}$$

$$c) \frac{2}{9} + \frac{5}{6}$$

$$d) \frac{1}{4} + \frac{3}{8}$$

18. Hisoblang.

$$a) \frac{2}{5} + \frac{3}{4} + \frac{1}{6}$$

$$b) \frac{3}{7} + \frac{1}{2} + \frac{5}{8}$$

$$c) \frac{2}{9} + \frac{5}{6} + \frac{1}{2}$$

$$d) \frac{5}{8} + \frac{4}{10} + \frac{11}{20}$$

19\*. Tenglamani yeching.

$$a) x + \frac{3}{7} = \frac{13}{14}$$

$$b) x + \frac{3}{13} = \frac{23}{39}$$

$$c) \frac{7}{15} + x = \frac{29}{45}$$

$$d) \frac{11}{16} + x = \frac{57}{64}$$



## Eslaymiz!

Ayirish qanday bajarilgan?

$$\frac{4}{6} - \frac{1}{6} = \frac{3}{6}$$

$$\frac{a}{b} - \frac{c}{b} = \frac{a-c}{b}$$

Agar kasrning maxrajli har xil bo'lsa, ayirish qanday bajariladi?



$$\frac{1}{2} - \frac{1}{6} = \frac{1}{3}$$



Har xil maxrajli kasrlarni ayirish uchun berilgan kasrlar bir maxrajga keltiriladi, so'ngra bir xil maxrajli kasrlarni ayirish qoidasiga rioya qilinadi.

$$\frac{1}{2} - \frac{1}{6} = ? \quad \Rightarrow \quad \frac{1 \times 3}{2 \times 3} - \frac{1}{6}$$

$$\frac{2}{9} - \frac{1}{6} = ? \quad \Rightarrow \quad \frac{2 \times 2}{9 \times 2} - \frac{1 \times 3}{6 \times 3}$$

$$\Rightarrow \frac{3}{6} - \frac{1}{6} = \frac{3-1}{6} = \frac{2}{6} = \frac{1}{3}$$

↑      ↑  
bir xil

$$\Rightarrow \frac{4}{18} - \frac{3}{18} = \frac{4-3}{18} = \frac{1}{18}$$

↑      ↑  
bir xil



## Guruhlarda ishlaymiz: 1–5.

1. Hisoblang.

a)  $\frac{1}{2} - \frac{1}{6}$

b)  $\frac{11}{15} - \frac{3}{5}$

c)  $\frac{4}{5} - \frac{13}{20}$

d)  $\frac{5}{6} - \frac{13}{18}$

2. Hisoblang.

a)  $\frac{7}{9} - \frac{1}{3} - \frac{5}{18}$

b)  $\frac{7}{8} - \frac{1}{4} - \frac{1}{6}$

c)  $\frac{3}{5} - \frac{3}{10} - \frac{2}{15}$

d)  $\frac{5}{6} - \frac{2}{9} - \frac{5}{12}$

3. Hisoblang.

a)  $\frac{13}{14} - \frac{3}{4}$

b)  $\frac{11}{12} - \frac{7}{8}$

c)  $\frac{14}{15} - \frac{7}{10}$

d)  $\frac{7}{16} - \frac{5}{12}$

4. Bayram arafasida bozorga keltirilgan  $\frac{14}{25}$  tonna apelsinning  $\frac{5}{40}$  tonnasi sotildi. Qancha apelsin sotilmay qolgan?

5. Tenglamani yeching.

a)  $x - \frac{5}{6} = \frac{1}{12}$

b)  $\frac{7}{9} - x = \frac{5}{18}$

c)  $x - \frac{3}{16} = \frac{5}{8}$

d)  $\frac{4}{5} - x = \frac{7}{20}$

Maxrajleri o'zaro tub bo'lgan kasrlarni ayirish.

$$\frac{2}{5} - \frac{3}{8} = \frac{2 \times 8 - 3 \times 5}{5 \times 8} = \frac{16 - 15}{40} = \frac{1}{40}$$



### Guruhlarda ishlaymiz: 6–10.

6. Hisoblang.

a)  $\frac{4}{5} - \frac{1}{2} - \frac{1}{6}$

b)  $\frac{5}{6} - \frac{2}{5} - \frac{1}{7}$

c)  $\frac{1}{2} - \frac{2}{7} - \frac{1}{5}$

d)  $\frac{11}{14} - \frac{1}{7} - \frac{1}{6}$

7. Amallarni bajaring.

a)  $\frac{3}{4} - \frac{1}{2} + \frac{1}{6}$ ;

b)  $\frac{5}{9} + \frac{7}{12} - \frac{2}{3}$

c)  $\frac{5}{8} - \frac{3}{10} + \frac{13}{20}$

d)  $\frac{13}{15} + \frac{1}{12} - \frac{2}{3}$

8. Velosipedchi tushgacha yo'ning  $\frac{3}{8}$  qismini, tushdan keyin  $\frac{1}{3}$  qismini bosib o'tdi. U kun davomida yo'ning qancha qismini bosib o'tgan?

9. Agar  $p = \frac{3}{5}; \frac{7}{9}; \frac{8}{15}; \frac{13}{20}$  bo'lsa,  $\frac{5}{6} - p$  ifodaning qiymatini toping.

10. Katalar o'rnidagi sonni toping.

a)  $\square - \frac{2}{5} = \frac{11}{20}$

b)  $\frac{5}{6} - \square = \frac{7}{18}$ ;

c)  $\frac{2}{3} - \square = \frac{3}{8}$

d)  $\square - \frac{2}{15} = \frac{7}{9}$



### Mustahkamlash: 11–17.

11. Hisoblang.

a)  $\frac{1}{2} - \frac{2}{5}$

b)  $\frac{1}{4} - \frac{1}{5}$

c)  $\frac{3}{5} - \frac{2}{7}$

d)  $\frac{8}{9} - \frac{7}{15}$

e)  $\frac{7}{11} - \frac{4}{7}$

f)  $\frac{19}{20} - \frac{13}{15}$

g)  $\frac{11}{18} - \frac{11}{30}$

h)  $\frac{17}{24} - \frac{19}{60}$

12. Amallarni bajaring.

a)  $\frac{2}{3} + \frac{1}{4} - \frac{5}{6}$

b)  $\frac{3}{5} + \frac{3}{10} - \frac{1}{2}$

c)  $\frac{7}{8} - \frac{5}{6} + \frac{5}{12}$

d)  $\frac{1}{3} - \frac{5}{24} + \frac{7}{18}$

13. Tenglamani yeching.

a)  $\frac{4}{5} + x = \frac{29}{30}$

b)  $x - \frac{3}{7} = \frac{11}{35}$

c)  $\left(x + \frac{2}{3}\right) - \frac{1}{12} = \frac{3}{4}$

14. Bo'sh kataklarni to'ldiring.

$$a) \frac{5}{6} - \frac{1}{3} = \frac{\square}{6} - \frac{\square}{6} = \frac{\square}{6} = \frac{\square}{2}$$

$$b) \frac{7}{12} - \frac{11}{20} = \frac{7 \times \square}{12 \times \square} - \frac{11 \times \square}{20 \times \square} = \frac{\square}{60} - \frac{\square}{60} = \frac{\square}{60} = \frac{\square}{\square}$$

15. O'ngdagi rasmdan foydalanib hisoblang.

ko'k rang    sariq rang  
qizil rang    jami rang



16. Jami binolar orasidagi masofa 3 km bo'lsa, noma'lum tomon uzunligi necha km?

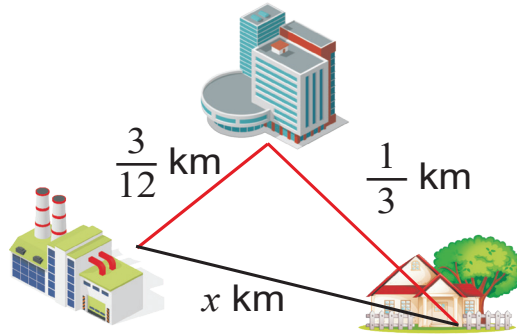

17. Amallarni bajaring.

	+ →		
- ↓	$\frac{19}{24}$	$\frac{3}{9}$	
	$\frac{5}{12}$	$\frac{3}{10}$	

	+ →		
- ↓	$\frac{12}{25}$	$\frac{11}{25}$	
	$\frac{13}{50}$	$\frac{11}{25}$	
	$\frac{14}{75}$	0	



Mustaqil ish: 18–20.

18. Ayirishni bajaring.

$$a) \frac{2}{3} - \frac{1}{6}$$

$$b) \frac{7}{8} - \frac{5}{16}$$

$$c) \frac{8}{9} - \frac{5}{6}$$

$$d) \frac{3}{4} - \frac{7}{10}$$

19. Hisoblang.

$$a) \frac{4}{5} - \frac{3}{7}$$

$$b) \frac{7}{9} - \frac{3}{5}$$

$$c) \frac{3}{4} - \frac{2}{9}$$

$$d) \frac{5}{8} - \frac{4}{11}$$

20. Hisoblang.

$$a) \frac{13}{14} - \frac{2}{7} - \frac{3}{28}$$

$$b) \frac{11}{16} - \frac{1}{4} - \frac{3}{8}$$

$$c) \frac{4}{5} - \frac{7}{20} - \frac{1}{4}$$





Eslaymiz!

Yig'indi va ayirmani hisoblash qanday bajarilgan?

$$1\frac{2}{5} + 3\frac{1}{5} = (1+3) + \left(\frac{2}{5} + \frac{1}{5}\right) = ?$$

$$3\frac{3}{5} - 2\frac{1}{5} = (3-2) + \left(\frac{3}{5} - \frac{1}{5}\right) = ?$$

Har xil maxrajli aralash sonlarni qo'shish qanday bajariladi?  
Ayirish-chi?

### 1-usul

$$4\frac{1}{4} + 1\frac{1}{3} = 4\frac{3}{12} + 1\frac{4}{12} = 5\frac{7}{12}$$

Har xil maxrajli aralash sonlarning kasr qismini bir xil maxrajga keltirib, bir xil maxrajli aralash sonlarni qo'shish (ayirish) qoidasiga amal qilinadi.

$$2\frac{3}{6} - 1\frac{7}{10} = 1\frac{9}{6} - 1\frac{7}{10} = 1\frac{45}{30} - 1\frac{21}{30} = \frac{24}{30} = \frac{4}{5}$$

Qo'shish natijasida kasr qismi noto'g'ri kasr bo'lganda undan butun qism ajratiladi va aralash sonning butun qismiga qo'shiladi.

$$2\frac{1}{2} + 1\frac{2}{3} = 2\frac{3}{6} + 1\frac{4}{6} = (2+1) + \left(\frac{3}{6} + \frac{4}{6}\right) = 3 + \frac{7}{6} = 3 + 1\frac{1}{6} = 4\frac{1}{6}$$



Guruhlarda ishlaymiz: 1-5.

1. Hisoblang.

a)  $2\frac{1}{4} + 3\frac{1}{4}$

b)  $6\frac{1}{5} + 3\frac{2}{5}$

c)  $3\frac{1}{2} + 2\frac{1}{2}$

d)  $7\frac{3}{8} + 5\frac{5}{8}$

e)  $12\frac{5}{7} - 7\frac{1}{2}$

f)  $11\frac{4}{9} - 5\frac{7}{18}$

g)  $9\frac{7}{12} - 5\frac{2}{3}$

h)  $8\frac{2}{5} - 3\frac{3}{4}$

2. Hisoblang.

a)  $8\frac{1}{4} + 3\frac{5}{12}$

b)  $7\frac{2}{5} + 5\frac{2}{15}$

c)  $3\frac{1}{5} + 5\frac{1}{3}$

d)  $6\frac{1}{7} + 3\frac{1}{2}$

e)  $10\frac{1}{4} - 8\frac{1}{3}$

f)  $15\frac{5}{7} - 9\frac{3}{4}$

g)  $9\frac{8}{14} - 3\frac{3}{4}$

h)  $8\frac{3}{8} - 6\frac{1}{12}$

3. Modellar asosida ifodalar tuzib, hisoblang.

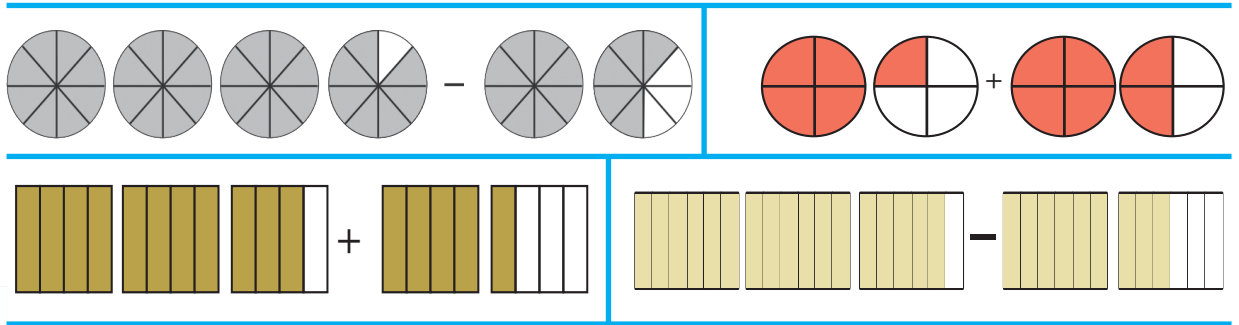

4. Sardor bozordan  $4\frac{1}{2}$  kg olma va  $1\frac{1}{3}$  kg shaftoli olib keldi. U jami necha kg meva olib kelgan?
5. Novvoyxonada tongda  $7\frac{3}{8}$  qop un non yopish uchun ajratildi. Tushgacha  $5\frac{1}{8}$  qop ishlatildi. Tushdan keyin non yopish uchun qancha qop un qoldi?



**Mustahkamlash: 6–20.**

6. Hisoblang.

a)  $5\frac{4}{5} + 2\frac{1}{3}$

b)  $7\frac{5}{7} + 5\frac{1}{2}$

c)  $11\frac{3}{4} + 3\frac{2}{7}$

d)  $4\frac{3}{5} + 5\frac{2}{3}$

e)  $7\frac{8}{15} - 5\frac{2}{5}$

f)  $12\frac{2}{5} - 9\frac{3}{10}$

g)  $8\frac{7}{12} - 6\frac{3}{4}$

h)  $10\frac{3}{4} - 5\frac{3}{8}$

7. Zafarda  $5\frac{2}{3}$  litr ko'k va  $2\frac{1}{4}$  litr qizil bo'yoq bor. Jami bo'yoqlar necha litr?

8. Zebo gullarga  $6\frac{1}{4}$  litr suv quydi.  $2\frac{5}{8}$  litr suv bilan mevalarni yuvdi. Zebo jami qancha suv ishlatdi?

9. Birinchi velosipedchi  $12\frac{4}{15}$  km, ikkinchi velosipedchi  $10\frac{5}{7}$  km yo'l yurishdi. Birinchi velosipedchi ikkinchi velosipedchidan qancha ko'p yo'l yurgan?

10. Modellar asosida ifodalar tuzib, hisoblang.

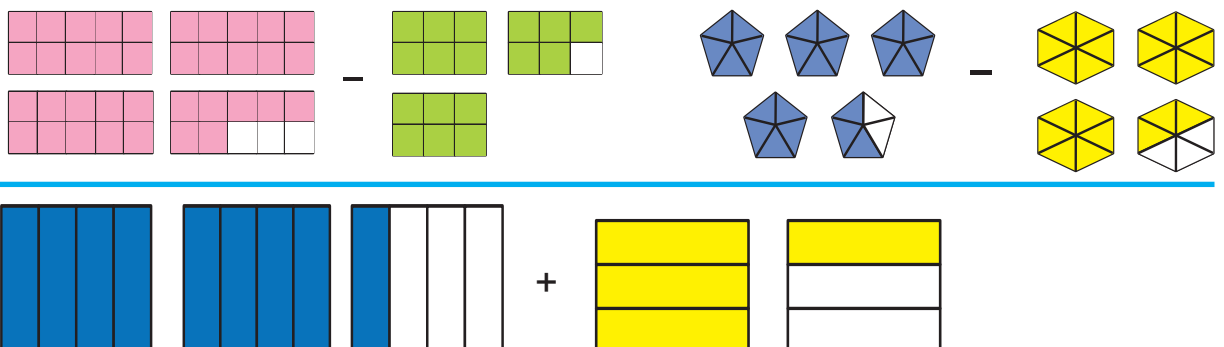

**2-usul**

$$\text{Qo'shish: } 1\frac{1}{12} + 2\frac{1}{8} = \frac{13}{12} + \frac{17}{8} = \frac{13 \times 2}{12 \times 2} + \frac{17 \times 3}{8 \times 3} = \frac{26}{24} + \frac{51}{24} = \frac{26+51}{24} = \frac{77}{24} = 3\frac{5}{24}$$

$$\text{Ayirish: } 2\frac{1}{15} - 2\frac{2}{45} = \frac{31}{15} - \frac{92}{45} = \frac{31 \times 3}{15 \times 3} - \frac{92}{45} = \frac{93}{45} - \frac{92}{45} = \frac{93-92}{45} = \frac{1}{45}$$

1-qadam: aralash sonni noto'g'ri kasrga aylantiramiz.

2-qadam: umumiy maxraj topamiz.

3-qadam: bir xil maxrajli kasrlarni qo'shish (ayirish) qoidasiga rioya qilamiz.

4-qadam: noto'g'ri kasrni aralash songa aylantiramiz.

**11.** Aralash sonlarni qo'shing.

a)  $12\frac{2}{3} + 13\frac{5}{9}$

b)  $6\frac{5}{6} + 4$

c)  $7 + 15\frac{3}{7}$

d)  $9\frac{1}{8} + 4\frac{1}{5}$

**12.** Velopoyga o'tkaziladigan yo'lning  $3\frac{3}{8}$  km qismi shaharda va  $5\frac{3}{4}$  km qismi shahar tashqarisida. Velopoyga yo'lining jami uzunligi qancha?

**13.** Ibrohim sovg'alarni tayyorlash uchun  $5\frac{1}{3}$  m yashil va  $4\frac{1}{4}$  m qizil tasma olib keldi. Jami qancha tasma olib kelingan?

**14.** Yorqin bog'dan  $5\frac{3}{5}$  kg uzum va  $4\frac{3}{10}$  kg gilos terdi. U jami necha kg meva tergan?

**15.** Binolar orasidagi jami masofa necha kilometr?

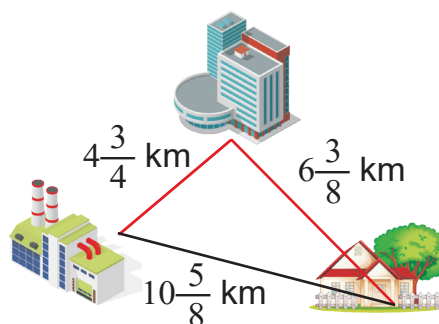

**16.** Natijalarni taqqoslang.

a)  $1\frac{5}{6} + 1\frac{1}{2} \square 5\frac{1}{2} - 1\frac{3}{4}$

b)  $5\frac{1}{3} - 3\frac{1}{2} \square 4\frac{5}{12} - 1\frac{5}{8}$

c)  $4\frac{1}{4} - 1\frac{1}{2} \square 2\frac{1}{4} + 1\frac{1}{4}$

**17.** Ifodaning qiymatini toping.

a)  $4\frac{3}{5} + 2\frac{5}{7} + 5\frac{9}{35}$

b)  $1\frac{2}{3} + 6\frac{4}{15} + 8\frac{17}{45}$

c)  $8\frac{3}{40} + 12\frac{11}{20} + 6\frac{7}{80}$

d)  $5\frac{7}{20} + 20\frac{4}{15} + 12\frac{11}{60}$

e)  $5\frac{2}{5} + 19\frac{9}{10} + 4\frac{33}{50}$

f)  $31\frac{7}{9} + 4\frac{11}{27} + 35\frac{43}{54}$

18. Ifodaning qiymatini toping.

$$a) \frac{31}{60} + \left( \frac{7}{20} + \frac{11}{60} \right)$$

$$b) \frac{53}{54} - \left( \frac{1}{6} + \frac{7}{9} \right)$$

$$c) \frac{13}{35} + \left( \frac{23}{35} - \frac{2}{7} \right)$$

$$d) \frac{7}{16} - \left( \frac{3}{4} - \frac{5}{16} \right)$$

$$e) \frac{79}{80} - \left( \frac{3}{16} + \frac{39}{80} \right)$$

$$f) \frac{2}{45} + \left( \frac{41}{45} - \frac{7}{9} \right)$$

$$g) \frac{7}{15} - \left( \frac{2}{15} + \frac{1}{5} \right)$$

$$h) \frac{3}{16} + \left( \frac{15}{16} - \frac{5}{8} \right)$$

$$i) \frac{9}{40} + \frac{3}{4} - \frac{19}{20}$$

19. A binodan B binogacha bo'lgan masofa qancha?

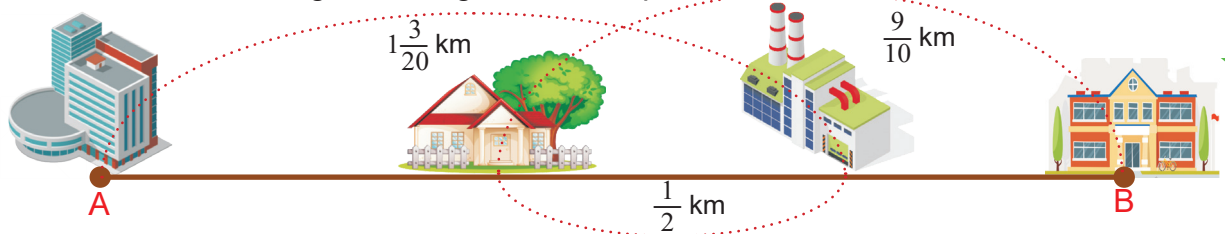

20. Ketma-ketlikdagi qonuniyatni toping va keyingi sonni aniqlang.

$$\frac{1}{3} \quad \frac{1}{2} \quad \frac{1}{5} \quad \frac{1}{4} \quad \frac{1}{7} \quad \frac{1}{8} \quad \frac{1}{9} \quad \frac{1}{16} \quad \frac{1}{11} \quad \frac{1}{32} \quad \text{---?}$$



**Mustaqil ish: 21–24.**

21. Aralash sonlarni qo'shing.

$$a) 11\frac{7}{15} + 4\frac{1}{3}$$

$$b) 7\frac{2}{5} + 3\frac{3}{10}$$

$$c) 5\frac{5}{12} + 2\frac{1}{4}$$

$$d) 4\frac{3}{8} + 1\frac{1}{4}$$

$$e) 2\frac{1}{4} + 3\frac{1}{3}$$

$$f) 7\frac{2}{5} + 5\frac{3}{4}$$

$$g) 10\frac{1}{15} + 3\frac{3}{10}$$

$$h) 5\frac{3}{8} + 4\frac{5}{12}$$

22. Quyidagi ayirmalar natijalariga mos shakllarni toping.

$$a) 6\frac{3}{5} - 4\frac{4}{8}$$

$$b) 4\frac{2}{3} - 2\frac{2}{4}$$

$$c) 5\frac{2}{4} - 3\frac{1}{5}$$

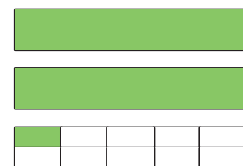
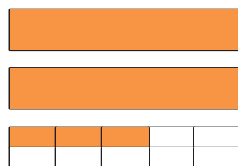
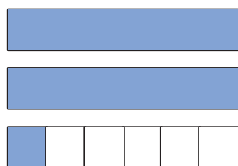

23. Zarifda  $5\frac{2}{5}$  kg va Zafarda  $4\frac{3}{8}$  kg bodom bor. Zarifda necha kg bodom ko'p?

24. Do'konda  $25\frac{14}{15}$  tonna un bor. Sotuvchi  $7\frac{7}{10}$  tonna un sotdi. Do'konda necha tonna un qoldi?

# II bob

## KASRLARNI KO'PAYTIRISH VA BO'LISH

$$\frac{4}{5} \times \frac{12}{13} = \frac{4 \times 12}{5 \times 13} = \frac{48}{65}$$

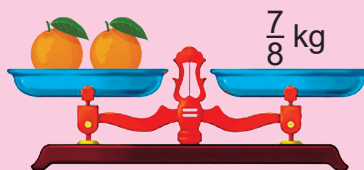
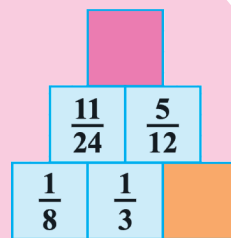

## KASRLARNI KO'PAYTIRISH



$$\frac{1}{2} \times \frac{3}{4} = \frac{1 \times 3}{2 \times 4} = \frac{3}{8}$$

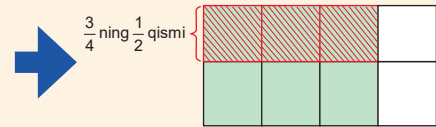
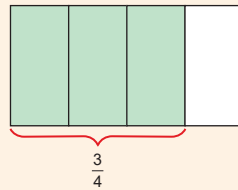

Kasrlarni ko'paytirish uchun ularning surati suratiga, maxraji maxrajiga ko'paytiriladi.

$$\frac{a}{b} \times \frac{c}{d} = \frac{a \times c}{b \times d}$$



Ko'paytirish jarayonida imkon bo'lgan hollarda kasrlarni qisqartirish mumkin.

$$\frac{\overset{1}{\cancel{2}}}{9} \times \frac{\underset{3}{\cancel{5}}}{\cancel{6}_3} = \frac{1}{9} \times \frac{5}{3} = \frac{1 \times 5}{9 \times 3} = \frac{5}{27}$$

$$\frac{\overset{3}{\cancel{24}}}{\underset{7}{\cancel{49}}_7} \times \frac{\overset{3}{\cancel{21}}}{\underset{4}{\cancel{32}}_4} = \frac{3}{7} \times \frac{3}{4} = \frac{3 \times 3}{7 \times 4} = \frac{9}{28}$$



## Guruhlarda ishlaymiz: 1-3.

1. Model yordamida kasrlarni hosil qiling va ularni ko'paytiring.

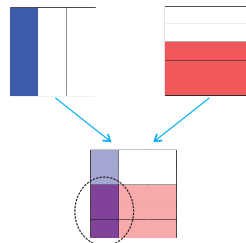

$$\frac{1}{3} \times \frac{3}{5} = ?$$

2. Hisoblang.

a)  $\frac{1}{2} \times \frac{1}{3}$

b)  $\frac{2}{3} \times \frac{5}{7}$

c)  $\frac{2}{5} \times \frac{1}{3}$

d)  $\frac{35}{40} \times \frac{4}{7}$

e)  $\frac{12}{13} \times \frac{5}{6}$

3. Bog'bon ikki kunda jami necha ar yerni shudgor qildi?

Birinchi kuni:

$$\frac{8}{9} \text{ ar}$$



Ikkinchi kuni:

$$?, \frac{3}{2} \text{ marta ko'p}$$



$$5 \times \frac{1}{4} = \frac{5 \times 1}{4} = \frac{5}{4} = 1 \frac{1}{4}$$



Natural sonni kasrga ko'paytirishda bu sonni kasrning suratiga ko'paytiramiz, maxraj o'zgarmay qoladi.

$$a \times \frac{b}{c} = \frac{a \times b}{c} \Leftrightarrow \frac{b}{c} \times a = \frac{b \times a}{c}$$

Ko'paytirish jarayonida natural sonni kasrning maxraji bilan qisqartirish mumkin.

$$\overset{5}{\cancel{45}} \times \frac{13}{\underset{7}{\cancel{63}}_7} = 5 \times \frac{13}{7} = \frac{5 \times 13}{7} = 9 \frac{2}{7}$$



### Guruhlarda ishlaymiz: 4–6.

4. Hisoblang.

a)  $5 \times \frac{2}{11}$

b)  $3 \times \frac{4}{13}$

c)  $4 \times \frac{2}{17}$

d)  $\frac{7}{32} \times 4$

5. Shakllarning perimetri va yuzini toping.

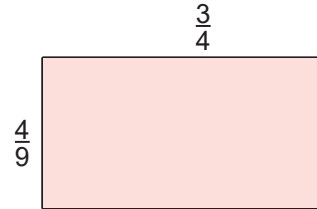
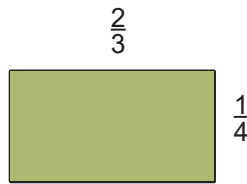
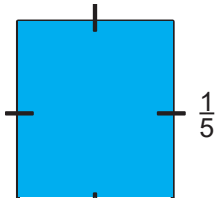

6. Daftarga 3 ta  $\frac{3}{10}$  dm li va 5 ta  $\frac{7}{10}$  dm li kesmalar chizildi. Chizilgan barcha kesmalar ketma-ket qo'yilsa, qanday uzunlikdagi kesma hosil bo'ladi?



### Qiziqarli matematika: 7.

7. Bo'sh kataklarga qanday amallar qo'yilsa, natija nolga teng bo'ladi?

	$\frac{1}{2}$	
$\frac{3}{4}$		$\frac{5}{8}$
		=
$\frac{3}{8}$		0

$\frac{1}{6}$		$\frac{2}{3}$		$\frac{1}{9}$	=	0
---------------	--	---------------	--	---------------	---	---

$\frac{1}{4}$		$\frac{1}{6}$
$\frac{1}{3}$		$\frac{2}{3}$
$\frac{3}{4}$	=	0



### Mustahkamlash: 8–19.

8. Kasrlarni ko'paytiring.

a)  $\frac{18}{23} \times \frac{7}{9}$

b)  $\frac{5}{12} \times \frac{3}{4}$

c)  $\frac{8}{21} \times \frac{7}{12}$

d)  $\frac{13}{18} \times \frac{9}{26}$

9. Hisoblang va taqqoslang.

a)  $20 \times \frac{3}{4} \bigcirc 30 \times \frac{2}{3}$

b)  $\frac{4}{7} \times 21 \bigcirc \frac{7}{25} \times 75$

c)  $\frac{5}{42} \times 12 \bigcirc \frac{3}{49} \times 14$

10. Maydon kvadrat shaklida.

Uning yuzi necha km<sup>2</sup>?

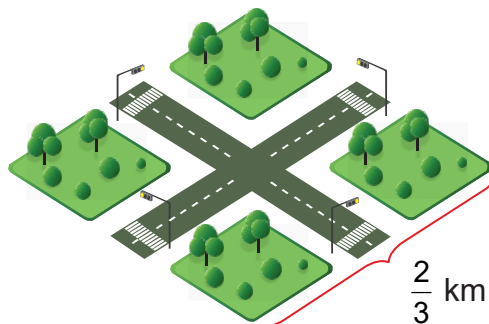

11. Ifodalarning qiymatini toping.

a)  $\frac{42}{45} \times \frac{15}{28} + 3\frac{4}{5}$

b)  $7\frac{8}{21} - \frac{18}{49} \times \frac{14}{27}$

c)  $10\frac{7}{10} + \frac{39}{55} \times \frac{22}{26}$

12. Bo'sh kataklarni to'ldiring.

a)  $\square \times \frac{3}{14} = \frac{3}{2}$

b)  $\square \times \frac{7}{6} = 21$

c)  $\frac{1}{6} \times \square = 3$

d)  $\square \times 5 = \frac{2}{3}$

e)  $\square \times 24 = 16$

13. To'g'ri to'rtburchaklarning bo'yalgan va bo'yalmagan qismlarini kasrlarda ifodalab, ko'paytiring.

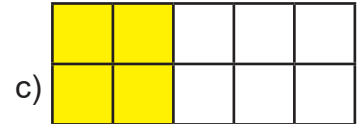
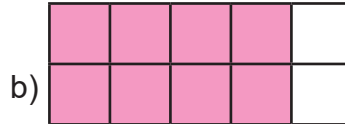

14. Supermarketdagi 4 ta xaltachada  $\frac{1}{4}$  kg dan shokolad bor. Xaltachalarda hammasi bo'lib qancha shokolad bor?

15. Hisoblang.

a)  $\left(\frac{7}{10} - \frac{4}{15}\right) \times \frac{4}{13}$

b)  $\left(\frac{1}{15} + \frac{1}{5}\right) \times \frac{15}{22}$

c)  $\frac{14}{25} \times \frac{22}{70} \times \frac{5}{11}$

d)  $\frac{16}{42} \times \frac{7}{8} \times \frac{3}{4}$

16\*. Rasm asosida masala tuzing.

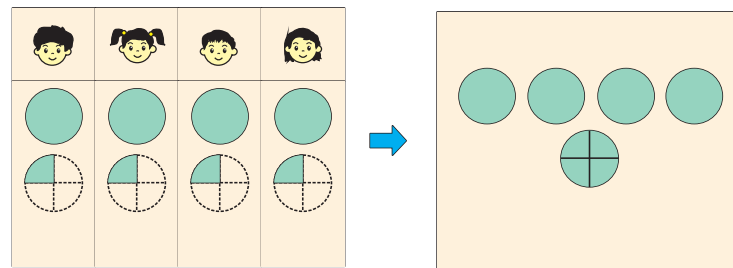

17. Ifodalarning qiymatini toping va taqqoslang.

a)  $\frac{7}{8} - \frac{3}{4} + \frac{1}{2}$   $\bigcirc$   $\frac{1}{3} + \frac{5}{6} - \frac{1}{2}$

b)  $\frac{2}{3} \times \frac{7}{8} \times \frac{2}{7}$   $\bigcirc$   $\frac{4}{5} - \frac{3}{5} \times \frac{1}{6}$

18. Ifodalarning qiymatini toping va taqqoslang.

a)  $\frac{5}{34} \times \frac{17}{45} + \frac{11}{45}$   $\bigcirc$   $\frac{5}{12} + \frac{8}{45} \times \frac{5}{12}$

b)  $\frac{5}{7} \times \frac{14}{15} - \frac{3}{7}$   $\bigcirc$   $\frac{8}{15} + \frac{5}{7} \times \frac{2}{15}$

19. Shakllarning hajmi va to'la sirti yuzini toping.

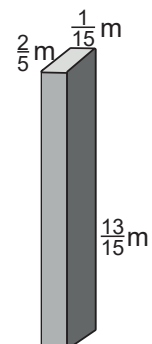
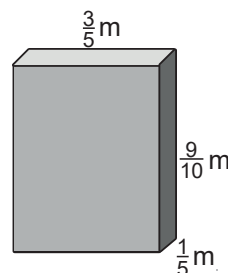
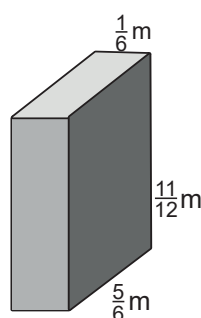
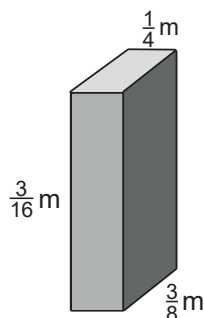



**Mustaqil ish: 20–27.**

20. Kasrlarni ko'paytiring.

$$a) \frac{2}{3} \times \frac{9}{10}$$

$$b) \frac{4}{9} \times \frac{15}{16}$$

$$c) \frac{15}{16} \times \frac{11}{30}$$

$$d) \frac{70}{100} \times \frac{5}{7}$$

21. Hisoblang.

$$a) \frac{2}{19} \times 7$$

$$b) \frac{9}{41} \times 3$$

$$c) \frac{13}{71} \times 5$$

$$d) \frac{11}{146} \times 13$$

22. To'g'ri to'rtburchakning bo'yi  $\frac{3}{4}$  dm, eni esa undan  $\frac{1}{8}$  dm qisqa. To'g'ri to'rtburchakning perimetri va yuzini toping.

23. Modellar asosida ko'paytirishni bajaring.

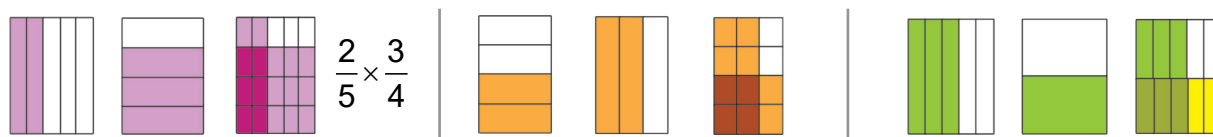

24. Bir dona pishiriq tayyorlash uchun  $\frac{1}{3}$  piyola sut ishlatiladi. 20 dona pishiriq tayyorlash uchun qancha sut kerak bo'ladi?

25. A dan B shahargacha bo'lgan masofa siniq chiziq bo'ylab necha kilometr?

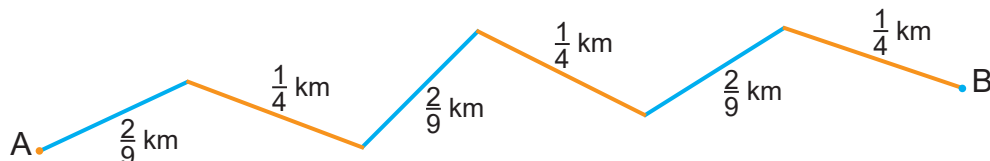

26. Hisoblang.

$$a) 28 \times \frac{3}{4} \times \frac{5}{7}$$

$$b) \frac{4}{5} \times \frac{2}{3} \times 15$$

$$c) 24 \times \frac{5}{6} \times \frac{3}{4}$$

$$d) \frac{2}{9} \times \frac{3}{4} \times 36$$

27. Bo'sh joylarni to'ldiring.

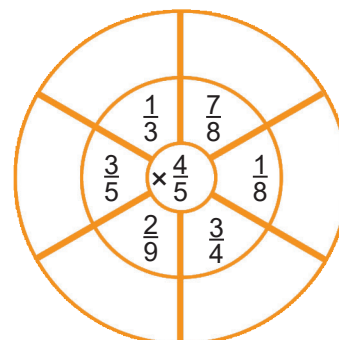
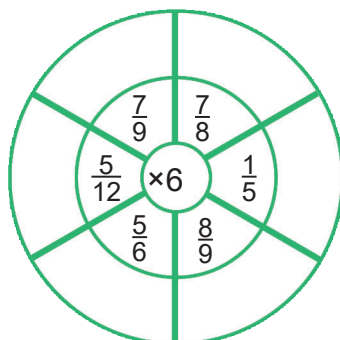
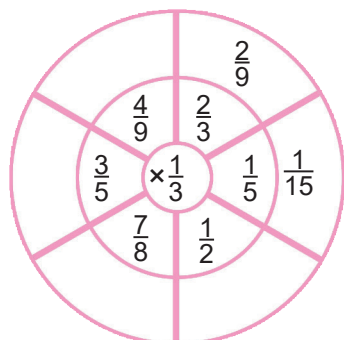



## Eslaymiz!

Kasrlarni ko'paytirish natijasida qanday son hosil bo'ldi?

$$\frac{4}{5} \times \frac{3}{2} = \frac{4 \times 3}{5 \times 2} = \frac{?}{?} = \frac{?}{?} = ? \quad \frac{2}{5} \times \frac{3}{2} = \frac{2 \times 3}{5 \times 1} = \frac{?}{?} = ?$$

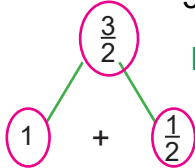

Bu son qanday hosil bo'lganini tushuntirib bera olasizmi?

$$\frac{3}{2} = 1 + \frac{1}{2}$$

$$\frac{6}{5} = 1 + \frac{1}{5}$$

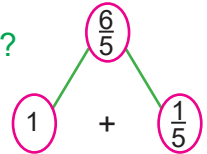

Aralash sonlarni ko'paytirish uchun ular noto'g'ri kasrga aylantiriladi va kasrlarni ko'paytirish qoidasiga amal qilinadi.

$$1\frac{3}{4} \times 2\frac{1}{2} = ?$$

$$1 \times 4 + 3 = 7$$

$$2 \times 2 + 1 = 5$$

$$\frac{7}{4} \times \frac{5}{2} = \frac{35}{8} = 4\frac{3}{8}$$



## Guruhlarda ishlaymiz: 1.

1. Aralash sonlarni ko'payting.

$$a) 1\frac{1}{4} \times 1\frac{2}{7} = \frac{\square}{4} \times \frac{\square}{7} = \frac{\square}{28} = \frac{\square}{28}$$

$$b) 2\frac{4}{9} \times 2\frac{2}{5} = \frac{\square}{9} \times \frac{12}{5} = \frac{\square}{15} = \frac{\square}{15}$$



$$1\frac{3}{14} \times \frac{21}{34} = ?$$

$$\frac{17}{14} \times \frac{21}{34} = \frac{1 \times 3}{2 \times 2} = \frac{3}{4}$$

Aralash sonlarni kasrga ko'paytirish uchun aralash sonni noto'g'ri kasrga aylantirib, kasrlarni ko'paytirish qoidasiga amal qilinadi.



## Guruhlarda ishlaymiz: 2.

2. Model asosida ko'paytmani toping.

$$1\frac{1}{2} \times 2 = \frac{\square}{2} \times \frac{2}{\square} = \frac{\square}{\square} = \square$$

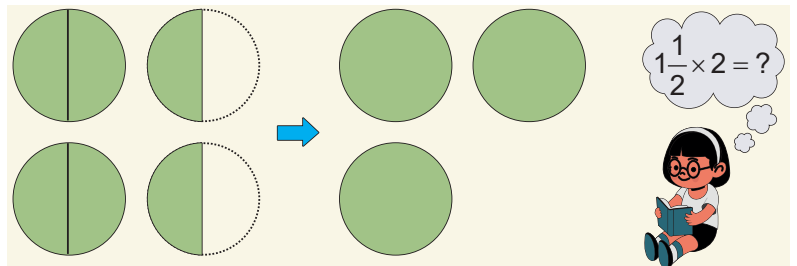

Aralash sonni natural songa ko'paytirish uchun aralash sonni noto'g'ri kasrga aylantirib, kasrni songa ko'paytirish qoidasiga amal qilinadi.

$$1\frac{3}{4} \times 2 = ?$$

$$\frac{7}{4} \times \frac{2}{1} = \frac{14}{4} = 3\frac{2}{4}$$



### Guruhlarda ishlaymiz: 3-4

3. Hisoblang.

$$a) 7 \times 1 \frac{2}{14} = 7 \times \frac{14_2}{14_2} = \frac{1 \times \square}{2} = \frac{\square}{2} = \square$$

$$b) 6 \times 1 \frac{1}{8} = 6 \times \frac{\square}{8_4} = \frac{3 \times \square}{4} = \frac{\square}{4} = \square \frac{\square}{\square}$$

$$c) 12 \times 4 \frac{1}{3} = 12 \times \frac{\square}{3_1} = \frac{4 \times \square}{1} = \square$$

$$d) 15 \times 2 \frac{1}{9} = 15 \times \frac{\square}{9_3} = \frac{5 \times \square}{3} = \frac{\square}{3} = \square \frac{\square}{\square}$$

4. Noma'lum son nechaga teng?

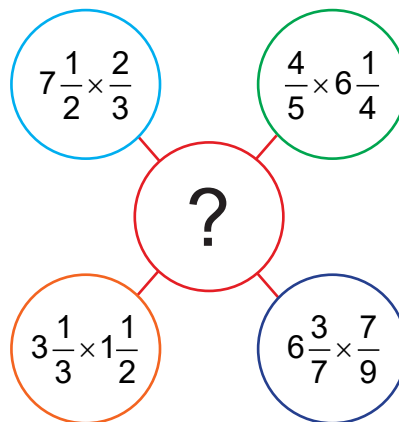

### Mustahkamlash: 5-10.

5. Aralash sonlarni ko'paytiring.

$$a) 1 \frac{2}{4} \times 3 \frac{5}{6}$$

$$b) 1 \frac{1}{6} \times 2 \frac{6}{12}$$

$$c) 2 \frac{1}{2} \times 3 \frac{1}{5}$$

$$d) 3 \frac{1}{3} \times 3 \frac{3}{10}$$

6. Hisoblang va natijalarni taqqoslang.

$$a) 3 \frac{2}{5} \times \frac{9}{17} \bigcirc \frac{11}{28} \times 6 \frac{4}{11} \quad b) 1 \frac{4}{15} \times 3 \frac{3}{19} \bigcirc 5 \frac{1}{9} \times \frac{18}{23} \quad c) 4 \frac{2}{15} \times \frac{5}{31} \bigcirc 1 \frac{5}{18} \times 72$$

7. Berilgan ma'lumotlar asosida maydonlarning perimetri va yuzini toping.

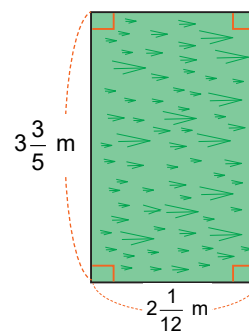
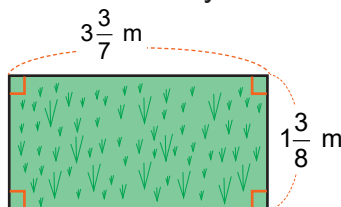

8. Ifodalar tuzing va qiymatini toping.

$$a) 4 \frac{2}{9} \times (a+b) \text{ bunda } a = 3 \frac{1}{3}, b = 5 \frac{2}{3}$$

$$b) 11 \frac{3}{5} \times a - 6 \frac{2}{3} \times b \text{ bunda } a = 2 \frac{1}{2}, b = 1 \frac{1}{5}$$

9. Ikkala sistemada jami qancha benzin bor?



$2 \frac{1}{10}$  tonna



?,  $3 \frac{1}{3}$  marta ko'p



10. Amallarni bajaring.

$$a) 12\frac{5}{6} + 2\frac{7}{9} \times \left(15\frac{9}{10} - 12\frac{9}{10}\right)$$

$$b) 13\frac{3}{8} + 4\frac{5}{7} \times \left(19\frac{3}{17} - 5\frac{3}{17}\right);$$

$$c) 3\frac{4}{17} \times 5\frac{2}{3} + 3\frac{4}{17} \times 11\frac{1}{3};$$

$$d) 5\frac{7}{16} \times 1\frac{3}{29} + 2\frac{5}{16} \times 2\frac{2}{7}$$



Mustaqil ish: 11–17.

11. Hisoblang.

$$a) 3\frac{3}{4} \times 3\frac{2}{9}$$

$$b) 3\frac{5}{6} \times 2\frac{1}{2}$$

$$c) 1\frac{1}{2} \times 3\frac{1}{2}$$

$$d) 1\frac{8}{12} \times 3\frac{2}{10}$$

$$e) 3\frac{2}{6} \times 3\frac{2}{3}$$

12. Bir idishda  $1\frac{4}{5}$  litr suv bor edi. Halim shunday suvdan 8 ta sotib oldi. U necha litr suv sotib olgan?

13. Jadvalni to'ldiring.

		→ ko'paytiring
	$1\frac{2}{3}$	$4\frac{4}{5}$
↓ ko'paytiring	$3\frac{3}{4}$	$2\frac{2}{15}$

14. Natijalarni taqqoslang.

$$a) 3 \times 1\frac{3}{8} \bigcirc 3 \times 2\frac{1}{2}$$

$$b) 16 \times 3\frac{7}{8} \bigcirc 1\frac{3}{8} \times 16$$

$$c) 3\frac{5}{7} \times 14 \bigcirc 14 \times 2\frac{3}{7}$$

15. Bolalar ta'tilda bog'dan  $\frac{3}{4}$  tonna o'rik, undan  $2\frac{1}{2}$  marta ko'p olma,  $1\frac{2}{3}$  marta ko'p shaftoli terishdi. Bolalar bog'dan hammasi bo'lib qancha meva terishgan?

16. Natijalarni taqqoslang.

$$a) 1\frac{3}{16} \times 48$$

$$b) 2\frac{3}{5} \times \left(1\frac{1}{4} + \frac{5}{8}\right)$$

$$c) 2\frac{2}{5} \times 10\frac{8}{9} - 2\frac{2}{5} \times 2\frac{5}{9}$$

17. Qaysi shakl  $2 \times \frac{1}{3}$  ko'paytmaga mos?

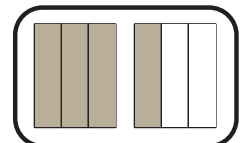
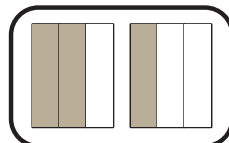
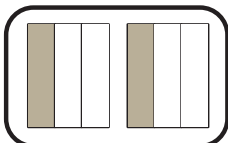

## SONNING QISMINI TOPISH



Jami doirachalarning  $\frac{1}{3}$  qismini toping.

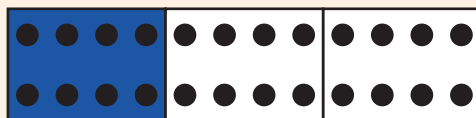

$$24 \times \frac{1}{3} = \frac{24 \times 1}{3} = \frac{8}{1} = 8$$



Sonning berilgan qismini topish uchun shu sonni uning qismini ifodalovchi kasrga ko'paytirish kerak.

$$a \times \frac{b}{c} = \frac{a \times b}{c}$$

$a, b, c$  – natural sonlar



## Guruhlarda ishlaymiz: 1–2.

1. Sonlarning  $\frac{1}{2}$  qismini toping.

10, 20, 30, 40, 50, 60, 70, 80, 90, 100.

2. Bo'sh kataklarni to'ldiring.

a)  $20 \times \frac{4}{5} = \frac{\square \times \square}{\square} = \frac{\square \times \square}{\square} = \square$

b)  $56 \times \frac{5}{7} = \frac{\square \times \square}{7} = \square \times \square = \square$

c)  $2 \times \frac{3}{10} = \frac{\square \times \square}{\square} = \frac{\square}{\square}$

d)  $144 \times \frac{5}{12} = \frac{\square \times \square}{12} = \frac{\square \times \square}{\square} = \square$



Aralash sonning qismini topish uchun aralash sonni noto'g'ri kasrga aylantirib, kasrlarni ko'paytirish qoidasiga amal qilinadi.

$4\frac{1}{6}$  ning  $\frac{3}{5}$  qismi:  $4\frac{1}{6} \times \frac{3}{5} = ?$



$$\frac{25}{6} \times \frac{3}{5} = \frac{25 \times 3}{6 \times 5} = \frac{75}{30} = \frac{5}{2} = 2\frac{1}{2}$$

$$\frac{5}{2} \times \frac{3}{5} = \frac{5 \times 1}{2 \times 1} = \frac{5}{2} = 2\frac{1}{2}$$



## Guruhlarda ishlaymiz: 3–6.

3. Aralash sonlarning qismini toping.

a)  $2\frac{2}{3}$  ning  $\frac{3}{5}$  qismi

b)  $1\frac{3}{4}$  ning  $\frac{2}{3}$  qismi

c)  $3\frac{3}{10}$  ning  $\frac{5}{11}$  qismi

4. Kesmaning uzunligi necha santimetr? Uning qanday qismlarini topa olasiz?

5. Do'konga keltirilgan 136 ta tarvuzning  $\frac{3}{8}$  qismi birinchi kuni,  $\frac{5}{17}$  qismi ikkinchi kuni sotildi. Do'konda nechta tarvuz qolgan?

6. a) 30 ning  $\frac{5}{6}$  qismiga 75 ning  $\frac{7}{15}$  qismini qo'shing

b) 180 ning  $\frac{13}{18}$  qismidan 115 ning  $\frac{17}{23}$  qismini ayiring



### Mustahkamlash: 7–16.

7. Hisoblang.

a) 56 ning  $\frac{3}{7}$  qismining  $\frac{1}{4}$  qismi

b) 91 ning  $\frac{11}{13}$  qismining  $\frac{2}{7}$  qismi

c) 780 ning  $\frac{7}{12}$  qismining  $\frac{11}{13}$  qismi

d) 798 ning  $\frac{12}{19}$  qismining  $\frac{5}{14}$  qismi

8. Aralash sonlarning qismini toping.

a)  $5\frac{1}{25}$  ning  $\frac{25}{42}$  qismi

b)  $3\frac{4}{7}$  ning  $\frac{21}{25}$  qismi

c)  $3\frac{2}{3}$  ning  $1\frac{1}{11}$  qismi

d)  $\frac{13}{20}$  ning  $3\frac{1}{3}$  qismi

9. Suratdagi pulning  $\frac{1}{2}$  qismi necha so'mni tashkil qiladi?

$\frac{3}{4}$  va  $\frac{1}{10}$  qismi-chi?



10. Uchburchakning perimetri 72 ga teng. Uning bir tomoni perimetrning  $\frac{1}{3}$  qismiga, ikkinchi tomoni  $\frac{5}{18}$  qismiga teng bo'lsa, uchburchakning uchinchi tomonini toping.

11. Bog'dan 120 kg meva terildi. Terilgan mevalarning  $\frac{5}{12}$  qismi bolalar oromgohiga,  $\frac{7}{24}$  qismi bolalar bog'chasiga yuborildi. Necha kilogramm meva qoldi?

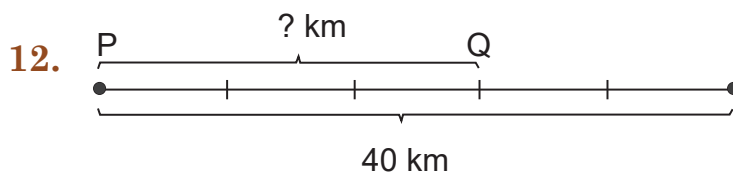

Nodir P shahardan Q shahargacha qancha yo'l yurgan?

13. Ifodalar tuzib, hisoblang.

a) 120 ning  $\frac{3}{8}$  qismiga 289 ning  $\frac{9}{17}$  qismini qo'shing

b) 720 ning  $\frac{3}{4}$  qismidan 550 ning  $\frac{7}{11}$  qismini ayiring

14. Maktabdagi 392 nafar o'quvchini tibbiy ko'rikdan o'tkazish rejalashtirilgan. Birinchi kuni o'quvchilarning  $\frac{2}{7}$  qismi, ikkinchi kuni esa qolganlarining  $\frac{3}{7}$  qismi tibbiy ko'rikdan o'tgan bo'lsa, yana nechta o'quvchi qolgan?

15. Sutkaning  $\frac{7}{12}$  qismi, yarmi, choragi, nimchoragi necha soatni tashkil qiladi? Bir soatning yarmi va choragini toping va minutlarda ifodalang.
16. Alisher aka plastik kartasidagi 2 500 000 so'mning  $\frac{1}{5}$  qismiga supermarketdan farzandlari uchun sovg'alar oldi. Qolgan pulining  $\frac{1}{2}$  qismini bank omonat kassasiga topshirdi. Alisher akaning plastik kartasida qancha pul qoldi?



### Mustaqil ish: 17–21.

17. Hisoblang.
- a) 80 ning  $\frac{17}{20}$  qismi      b) 100 ning  $\frac{21}{25}$  qismi      c) 77 ning  $\frac{3}{11}$  qismi
- d) 540 ning  $\frac{19}{27}$  qismi      e) 533 ning  $\frac{5}{13}$  qismi      f) 434 ning  $\frac{11}{14}$  qismi
18. 4 kilometrli yo'lning  $\frac{3}{8}$  qismiga asfalt yotqizildi. Necha metr yo'lga asfalt yotqizilgan?
19. Kutubxonada 1250 ta kitob bor. Bu kitoblarning  $\frac{2}{5}$  qismi o'zbek tilida,  $\frac{3}{10}$  qismi rus tilida,  $\frac{1}{5}$  qismi ingliz tilida, qolganlari nemis tilida bo'lsa, har bir tilda qanchadan kitob bor?
20. Muqaddas tug'ilgan kunida dugonalari uchun 72 ta shokolad olib keldi. Hamma ketgandan keyin shokoladlarning  $\frac{1}{3}$  qismi qolganini ko'rdi. Muqaddasda qancha shokolad qolgan?
21. 1) 30 ning  $\frac{5}{6}$  qismiga 75 ning  $\frac{7}{15}$  qismini qo'shing
- 2) 800 ning  $\frac{3}{4}$  qismidan 660 ning  $\frac{7}{11}$  qismini ayiring
22. Urganchdan Toshkentgacha bo'lgan masofa 1000 km. Olim bu masofani turli transportlarda bosib o'tdi. U har bir transportda necha kilometrdan yo'l yurgan?

		
$\frac{1}{8}$ qismi	$\frac{3}{8}$ qismi	$\frac{1}{2}$ qismi

## QULAY USULLARDA HISOBLASH



### Eslaymiz!



Berilgan xossalar qanday ma'noni bildiradi?

O'rin almashtirish xossasi:  $a \times b = b \times a$

Guruhlash xossasi:  $(a \times b) \times c = a \times (b \times c)$

Taqsimot xossasi:  $(a + b) \times c = a \times c + b \times c$

Bu xossalarni kasr sonlar uchun tatbiq qila olamizmi?



### Guruhlarda ishlaymiz: 1-5.

$$\text{! } \frac{4}{5} \times \frac{12}{13} = \frac{4 \times 12}{5 \times 13} = \frac{48}{65} \qquad \frac{12}{13} \times \frac{4}{5} = \frac{12 \times 4}{13 \times 5} = \frac{48}{65}$$

**1.** Tenglikning to'g'riligini tekshiring.

a)  $\frac{4}{7} \times \frac{12}{13} = \frac{12}{13} \times \frac{4}{7}$

b)  $1 \frac{2}{17} \times \frac{7}{12} = \frac{7}{12} \times 1 \frac{2}{17}$

c)  $4 \frac{1}{9} \times 5 \frac{8}{11} = 5 \frac{8}{11} \times 4 \frac{1}{9}$

$$\text{! } \frac{4}{5} \times \left( \frac{15}{16} \times \frac{4}{3} \right) = \frac{4}{5} \times \frac{15}{16} \times \frac{4}{3} = \frac{3 \times 4}{4 \times 3} = 1$$

**2.** Hisoblang.

a)  $14 \times \left( \frac{5}{7} \times \frac{1}{2} \right)$

b)  $\left( \frac{1}{2} \times \frac{3}{4} \right) \times 8$

c)  $24 \times \left( \frac{5}{12} \times \frac{1}{2} \right)$

$$\text{! } \frac{4}{5} \times \left( \frac{15}{16} + \frac{20}{64} \right) = \left( \frac{4}{5} \times \frac{15}{16} \right) + \left( \frac{4}{5} \times \frac{20}{64} \right) = \frac{3}{4} + \frac{4}{16} = \frac{12+4}{16} = \frac{16}{16} = 1$$

**3.** Hisoblang.

a)  $2 \times \left( 3 + \frac{1}{2} \right)$

b)  $3 \times \left( 4 + \frac{2}{3} \right)$

c)  $\left( 2 + \frac{4}{5} \right) \times 5$

**4.** Bo'sh kataklarni to'ldiring.

a)  $\frac{20}{25} \times \frac{4}{5} = \frac{\square}{\square} \times \frac{\square}{\square} = \frac{\square}{\square}$

b)  $\frac{16}{35} \times \left( \frac{15}{16} \times \frac{35}{150} \right) = \frac{\square}{\square} \times \frac{\square}{\square} \times \frac{\square}{\square} = \frac{\square}{\square}$

c)  $\frac{16}{35} \times \left( \frac{15}{16} + \frac{35}{64} \right) = \left( \frac{\square}{\square} \times \frac{\square}{\square} \right) + \left( \frac{\square}{\square} \times \frac{\square}{\square} \right) = \frac{\square}{\square} + \frac{\square}{\square} = \frac{\square}{\square} + \frac{\square}{\square} = \frac{\square}{\square}$



$$! \quad 2 \times 1 \frac{25}{64} = (2 \times 1) + \left( 2 \times \frac{25}{64} \right) = 2 + \frac{25}{32} = 2 \frac{25}{32}$$

5. Hisoblang.

a)  $12 \times 3 \frac{1}{8}$

b)  $8 \times 2 \frac{1}{4}$

c)  $6 \times 1 \frac{5}{7}$

d)  $10 \times 2 \frac{5}{12}$



### Mustahkamlash: 6-12.

6. Qulay usul bilan hisoblang.

a)  $5 \frac{7}{11} \times \frac{7}{11} - 18 \frac{7}{11} \times \frac{7}{11}$

b)  $5 \frac{7}{11} \times \frac{7}{11} - 18 \frac{7}{11} \times \frac{7}{11}$

c)  $2 \frac{9}{37} \times 10 \frac{4}{15} + 26 \frac{11}{15} \times 2 \frac{9}{37}$

d)  $6 \frac{13}{24} \times 7 \frac{1}{2} - 6 \frac{5}{24} \times 7 \frac{1}{2}$

7. To'g'ri to'rtburchakning bo'yi  $2 \frac{7}{8}$  dm, eni esa  $1 \frac{3}{4}$  dm ga teng. Shu to'g'ri to'rtburchakning perimetrini toping.

8. Ifodaning qiymatini toping.

a)  $2 \frac{2}{11} \times (a + b)$ , bunda  $a = 3 \frac{1}{3}$ ,  $b = 5 \frac{5}{6}$

b)  $5 \frac{4}{7} \times a - 6 \frac{1}{2} \times b$ , bunda  $a = 4 \frac{4}{13}$ ,  $b = 2 \frac{4}{13}$

c)  $5 \frac{5}{6} \times a - 4 \frac{7}{12} \times a + 2 \frac{1}{4} \times a$ , bunda  $a = 4$ ,  $\frac{2}{3}$

d)  $2 \frac{11}{15} \times a + 1 \frac{3}{5} \times a - \frac{14}{15} \times a$ , bunda  $a = 5$ ,  $4 \frac{1}{2}$

9. To'g'ri to'rtburchakning eni  $3 \frac{5}{12}$  dm, bo'yi esa enidan  $1 \frac{5}{6}$  dm ortiq. Uning perimetrini toping.

10. To'g'ri to'rtburchakning bo'yi  $5 \frac{3}{8}$  dm, eni esa undan  $1 \frac{4}{5}$  dm qisqa. Uning perimetrini toping.

11. Tenglikning to'g'riligini tekshiring.

a)  $\left( \frac{2}{5} \times \frac{3}{4} \right) \times \frac{7}{13} = \frac{2}{5} \times \left( \frac{3}{4} \times \frac{7}{13} \right)$

b)  $55 \times \left( \frac{3}{5} + \frac{7}{11} \right) = 55 \times \frac{3}{5} + 55 \times \frac{7}{11}$

12. Farg'onadan Toshkentgacha bo'lgan masofa 372 km. Jamshid shu masofaning  $\frac{1}{3}$  qismini bosib o'tdi. Manzilga yana necha kilometr masofa qoldi?



**Mustaqil ish: 13–15.**

13. Namuna asosida mos natijalarni toping.

1	$4 \times \left(5 + \frac{1}{4}\right)$
2	$7 \times \left(2 + \frac{3}{7}\right)$
3	$2 \times \left(3 - \frac{1}{2}\right)$
4	$\left(4 - \frac{7}{9}\right) \times 9$
5	$56 \times \left(\frac{9}{14} \times \frac{1}{2}\right)$
6	$\left(\frac{1}{2} \times \frac{3}{4}\right) \times 8$
7	$\left(\frac{24}{5} \times \frac{2}{3}\right) \times \frac{5}{4}$
8	$\frac{7}{3} \times \left(\frac{9}{7} \times 2\right)$

a	17
b	18
c	4
d	3
e	21
f	6
g	5
h	29

14. Hisoblang.

a)  $\frac{5}{8} \times \left(7 \times \frac{4}{5}\right)$

b)  $\left(\frac{2}{5} \times 7\right) \times \frac{15}{2}$

c)  $\left(5 + \frac{1}{3}\right) \times 6$

d)  $7 \times \left(5 - \frac{3}{7}\right)$

e)  $\left(8 - \frac{11}{13}\right) \times 13$

f)  $\left(\frac{2}{5} \times \frac{3}{4}\right) \times 2$

15. Hisoblang.

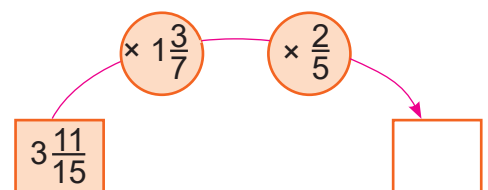
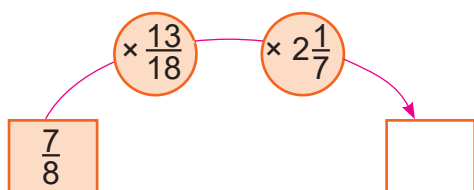

## O'ZARO TESKARI SONLAR



$$\begin{array}{c} \frac{3}{8} \\ \text{O'zaro teskari} \rightarrow \frac{8}{3} \end{array}$$

$$\begin{array}{c} \frac{a}{b} \\ \text{O'zaro teskari} \rightarrow \frac{b}{a} \end{array}$$

$$\frac{3}{8} \times \frac{8}{3} = 1$$

O'zaro teskari sonlarning ko'paytmasi 1 ga teng.

$$\frac{a}{b} \times \frac{b}{a} = 1$$

$$n \neq \frac{1}{n} \quad \cancel{0 = \frac{1}{0}}$$



## Guruhlarda ishlaymiz: 1–3.

1. Berilgan sonlarga teskari sonni toping:  $\frac{3}{4}$ ;  $\frac{5}{8}$ ;  $\frac{4}{15}$ ;  $1\frac{2}{3}$ ;  $2\frac{5}{6}$ ;  $\frac{15}{4}$ ;  $\frac{1}{7}$ ;  $\frac{1}{25}$ .

2. Quyidagi sonlarga teskari sonlarni toping.

a) 4    b) 5    c) 10    d) 150

3. Quyidagi sonlar o'zaro teskarimi?

a)  $\frac{5}{4}$  va  $\frac{4}{5}$     b)  $\frac{1}{12}$  va 12    c)  $\frac{9}{13}$  va  $1\frac{4}{9}$     d)  $\frac{8}{17}$  va  $2\frac{1}{8}$

e)  $\frac{4}{25}$  va  $6\frac{1}{4}$     f)  $3\frac{1}{2}$  va  $1\frac{3}{2}$     g)  $\frac{7}{16}$  va  $2\frac{2}{7}$     h) 9 va  $\frac{1}{9}$



## Mustahkamlash: 4–8.

4. Quyidagi sonlarga teskari sonlarni toping.

a) 2    b) 6    c) 40    d) 200    e)  $\frac{1}{50}$     f)  $\frac{1}{200}$

5. Kasrlarga o'zaro teskari kasrlarni toping va natijalarni taqqoslang.

a)  $4\frac{2}{3}$  va  $1\frac{3}{4}$     b)  $5\frac{1}{4}$  va  $5\frac{5}{6}$

6. Sonning qismini va unga teskari sonni toping.

a)  $15\frac{3}{4}$  sonining  $\frac{1}{9}$  qismi    b)  $32\frac{3}{5}$  sonining  $\frac{5}{17}$  qismi

7. Amallarni bajaring va natijaga teskari sonni toping.

a)  $2\frac{3}{5} + 3\frac{1}{4}$

b)  $8\frac{7}{12} - 5\frac{5}{9}$

c)  $\frac{3}{4} + \frac{7}{12}$

d)  $\frac{11}{34} + \frac{15}{17}$

e)  $2\frac{1}{4} \times 3\frac{1}{9}$

f)  $6\frac{5}{12} \times 2\frac{2}{11}$

8. 6 va  $\frac{5}{12}$  sonlari yig'indisi, ayirmasi va ko'paytmasiga teskari sonlarni toping.



### Qiziqarli matematika: 9–10.

9. O'zaro teskari sonlardan birini  $k$  marta ortirsak, ko'paytma o'zgarماسligi uchun ikkinchi sonni nechaga ko'paytirish (yoki bo'lish) kerak?

10. O'zaro teskari sonlar ko'paytmasi 1 ga tengligidan foydalanib A, B, C, D, E va F harflarning o'rnida bo'lishi kerak bo'lgan sonlarni toping.

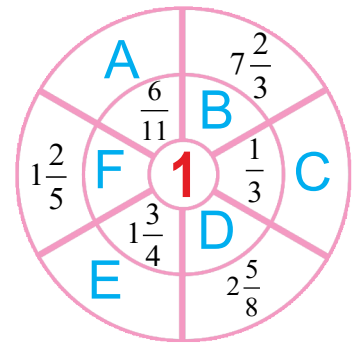

### Mustaqil ish: 11–13.

11. Berilgan sonlarga teskari sonni toping.

a)  $\frac{5}{7}$     b)  $\frac{9}{25}$     c)  $4\frac{3}{7}$     d)  $5\frac{2}{3}$     e)  $2\frac{5}{14}$     f)  $3\frac{7}{10}$

12.

a)  $4\frac{2}{3}$  va  $1\frac{3}{4}$  sonlariga teskari bo'lgan sonlarni taqqoslang.

b)  $5\frac{3}{4}$  va  $5\frac{5}{8}$  sonlariga teskari bo'lgan sonlarni taqqoslang.

13.

a)  $\frac{3}{4}$  va  $\frac{6}{13}$  sonlariga teskari sonlar yig'indisini toping.

b)  $\frac{5}{24}$  va  $\frac{15}{17}$  sonlariga teskari sonlar ayirmasini toping.

## KASRLARNI BO'LISH



1-usul:  $7 \div 3 = \frac{7}{3} = 2\frac{1}{3}$

2-usul:  $7 \div 3 = 7 \times \frac{1}{3} = \frac{7 \times 1}{3} = 2\frac{1}{3}$



## Guruhlarda ishlaymiz: 1-7.

1. Bo'sh kataklarni to'ldiring.

a)  $5 \div 2 = \frac{\square}{2} = \square \frac{\square}{\square}$

b)  $8 \div 7 = \frac{\square}{\square} = \square \frac{\square}{\square}$

c)  $19 \div 4 = \frac{\square}{\square} = \square \frac{\square}{\square}$

2. Bo'lishni bajaring.

a)  $14 \div 28$

b)  $5 \div 18$

c)  $21 \div 10$

d)  $25 \div 9$

3. Har bir stakanga necha litrdan suv quyish mumkin?



$3 \div 8 = \frac{\square}{\square} \text{ L}$



$1 \div 4 = \frac{\square}{\square} \text{ L}$



$\frac{1}{2}$  ta pitsani 2 bolaga teng taqsimlash mumkinmi?

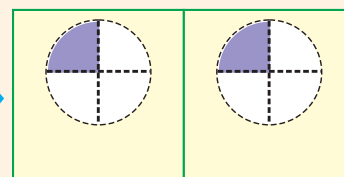
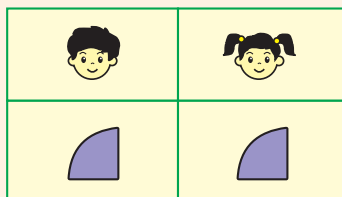
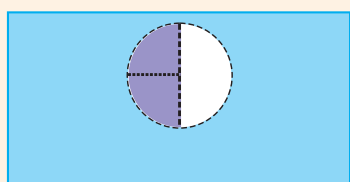

1-usul:  $\frac{2}{4} \div 2 = \frac{2 \div 2}{4} = \frac{1}{4}$

2-usul:  $\frac{1}{2} \div 2 = \frac{1}{2} \div \frac{2}{1} = \frac{1}{2} \times \frac{1}{2} = \frac{1}{4}$

4. Bo'sh kataklarni to'ldiring.

a)  $\frac{12}{25} \div 3 = \frac{\square}{25} \div 3 = \frac{\square}{25}$

b)  $\frac{15}{17} \div 3 = \frac{\square}{17} \div \frac{\square}{\square} = \frac{\square}{17}$

c)  $\frac{21}{29} \div 7 = \frac{\square}{\square} \div \frac{\square}{\square} = \frac{\square}{\square}$

5. Bo'lishni bajaring.

a)  $\frac{3}{4} \div 3$

b)  $\frac{4}{7} \div 2$

c)  $\frac{6}{13} \div 6$

d)  $\frac{10}{11} \div 2$

6. Hisoblang.

a)  $1 \div \frac{1}{3}$

b)  $1 \div \frac{1}{7}$

c)  $\frac{7}{9} \div 1$

d)  $\frac{3}{10} \div 1$



Kasrlarni bo'lish uchun ikkinchi kasr (bo'luvchi) teskari kasrga aylantiriladi va kasrlarni ko'paytirish qoidasiga rioya qilinadi.

$$\frac{1}{4} \div \frac{5}{4} = \frac{1}{4} \times \frac{4}{5} = \frac{1}{5}$$

7. Bo'lishni bajaring.

a)  $\frac{1}{2} \div \frac{2}{3}$

b)  $\frac{2}{5} \div \frac{3}{7}$

c)  $\frac{2}{9} \div \frac{1}{4}$

d)  $\frac{3}{11} \div \frac{1}{3}$

e)  $\frac{1}{6} \div \frac{2}{7}$

f)  $\frac{3}{4} \div \frac{15}{16}$

g)  $\frac{11}{18} \div \frac{11}{12}$

h)  $\frac{49}{68} \div \frac{21}{34}$



**Mustahkamlash: 8–14.**

8. Bir dona mevaning og'irligi qancha?

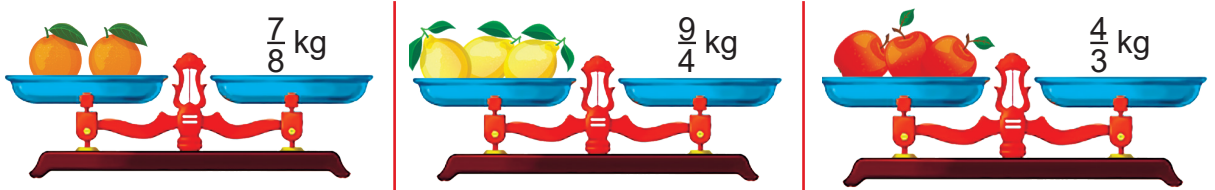

9. Hisoblang va natijalarni taqqoslang.

$6 \div \frac{3}{8}$	?	<input type="radio"/>	$6 \div \frac{8}{3}$	?
$12 \div \frac{4}{5}$	?	<input type="radio"/>	$12 \div \frac{5}{4}$	?
$5 \div \frac{7}{8}$	?	<input type="radio"/>	$5 \div \frac{8}{7}$	?
$7 \div \frac{3}{4}$	?	<input type="radio"/>	$7 \div \frac{4}{3}$	?

10. Rasm asosida masala tuzing va izohlang.

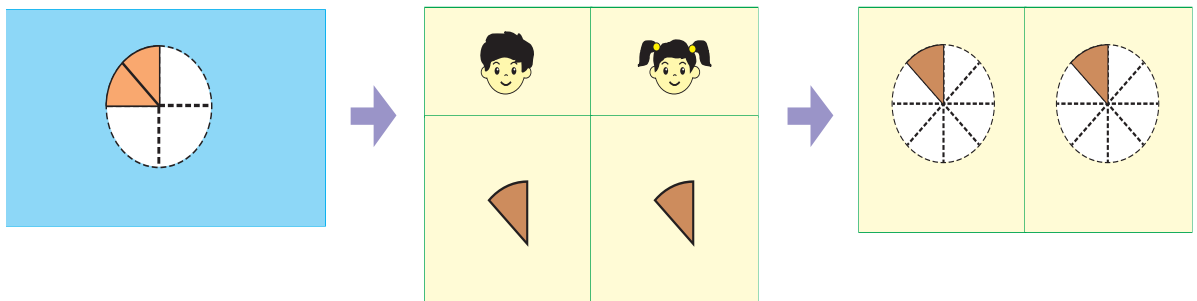

11. Hisoblang.

a)  $\frac{1}{2} \div \frac{3}{5}$

b)  $\frac{33}{36} \div 55$

c)  $\frac{7}{19} \div \frac{14}{19}$

d)  $\frac{17}{24} \div \frac{51}{56}$

12. Natijalarni toping. Qanday xulosaga keldingiz?

Bo'lish	Ko'paytirish
$\frac{3}{4} \div 4$	$\frac{3}{4} \times \frac{1}{4}$
$\frac{5}{8} \div 2$	$\frac{5}{8} \times \frac{1}{2}$
$\frac{2}{3} \div 4$	$\frac{2}{3} \times \frac{1}{4}$

13. Hisoblang.

a)  $\left(\frac{3}{4} \div \frac{1}{4}\right) \div \left(\frac{3}{10} \div \frac{1}{2}\right)$

b)  $\left(\frac{2}{3} \div \frac{6}{12}\right) \div \left(\frac{3}{4} \div \frac{3}{6}\right)$

c)  $\left(\frac{3}{7} \div \frac{4}{8}\right) \div \left(\frac{1}{7} \div \frac{2}{4}\right)$

14. Bolalarga 12 ta pitsa teng taqsimlab berildi. Har bir bola  $\frac{2}{3}$  bo'lak pitsa oldi. Pitsa nechta bolaga taqsimlab berilgan?



**Qiziqarli matematika: 15.**

15. Chizma asosida ifoda tuzing va natijani toping.

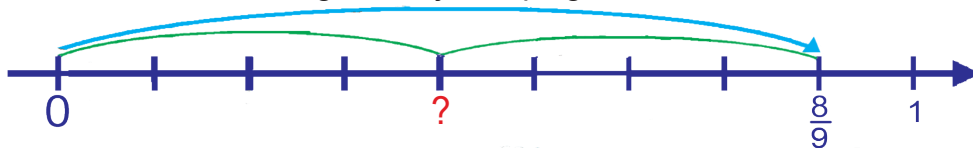

**Mustaqil ish: 16–18.**

16. Berilgan rasmlarga mos bo'lish amalini toping.

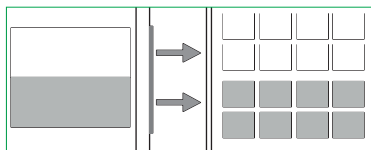

a)  $6 \div \frac{3}{4} = 8$

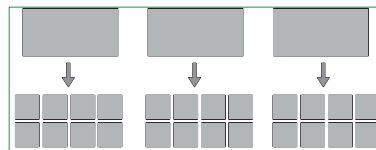

b)  $\frac{1}{2} \div \frac{1}{16} = 8$

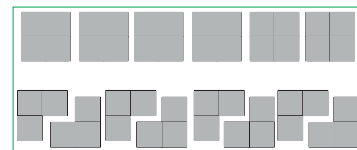

c)  $3 \div \frac{1}{8} = 24$

17. Hisoblang.

a)  $4 \div \frac{1}{5}$

b)  $6 \div \frac{1}{2}$

c)  $5 \div \frac{1}{4}$

d)  $10 \div \frac{5}{7}$

e)  $14 \div \frac{7}{8}$

f)  $25 \div \frac{5}{6}$

g)  $\frac{4}{5} \div 8$

h)  $\frac{9}{10} \div 27$

i)  $\frac{7}{9} \div 14$

g)  $\frac{12}{13} \div 6$

k)  $\frac{15}{16} \div 10$

## ARALASH SONLARNI BO'LISH



Aralash sonni kasrga bo'lish uchun aralash son noto'g'ri kasrga keltirilib, kasrlarni bo'lish qoidasiga rioya qilinadi.

$$1\frac{4}{5} \div \frac{3}{35} = \frac{9}{5} \div \frac{3}{35} = \frac{9}{5} \times \frac{35}{3} = \frac{3 \times 7}{1} = 21$$

$$2\frac{2}{3} \div 4 = \frac{8}{3} \div \frac{4}{1} = \frac{8}{3} \times \frac{1}{4} = \frac{2}{3}$$



O'zingiz xulosa qiling.



## Guruhlarda ishlaymiz: 1-2.

1. Bo'sh kataklarni to'ldiring.

a)  $1\frac{1}{5} \div 2 = \frac{\square}{5} \div \frac{2}{\square} = \frac{\square}{5} \times \frac{\square}{2} = \frac{\square}{5}$

b)  $2\frac{2}{3} \div 4 = \frac{\square}{\square} \div \frac{\square}{\square} = \frac{\square}{\square} \times \frac{\square}{\square} = \frac{\square}{\square}$

c)  $1\frac{5}{9} \div \frac{7}{18} = \frac{\square}{\square} \div \frac{\square}{\square} = \frac{\square}{\square} \times \frac{\square}{\square} = \frac{\square}{\square}$

2. Hisoblang.

a)  $\frac{5}{8} \div 3\frac{1}{2}$

b)  $\frac{7}{8} \div 2\frac{1}{5}$

c)  $\frac{5}{7} \div 3\frac{2}{3}$

d)  $\frac{7}{15} \div 3\frac{1}{7}$

e)  $3\frac{1}{2} \div 2\frac{1}{3}$

f)  $2\frac{5}{8} \div 1\frac{3}{4}$



## Mustahkamlash: 3-15.

3.  $6\frac{2}{5}$  gektar yerdan  $33\frac{3}{5}$  tonna hosil olindi. 1 gektar yerdan necha tonna hosil olingan?

4. Jadvalni to'ldiring.

$a$	$\frac{7}{9}$	$1\frac{3}{5}$		5	$1\frac{24}{25}$	$8\frac{1}{3}$	$\frac{7}{10}$	
$b$	$\frac{3}{7}$		$\frac{5}{14}$		$1\frac{2}{3}$			$5\frac{1}{3}$
$a \times b$		1		10		1	$3\frac{1}{3}$	
$a \div b$			$2\frac{1}{2}$					8



5. To'g'ri to'rtburchakning yuzi  $42\frac{2}{3}$  dm<sup>2</sup> ga, bo'yi  $8\frac{4}{9}$  dm ga teng. To'g'ri to'rtburchakning enini toping.
6. To'g'ri to'rtburchakning yuzi 52 dm<sup>2</sup> ga, balandligi  $6\frac{1}{2}$  dm ga teng. To'g'ri to'rtburchakning asosini toping.
7. Noma'lum bo'lak uzunligini toping.

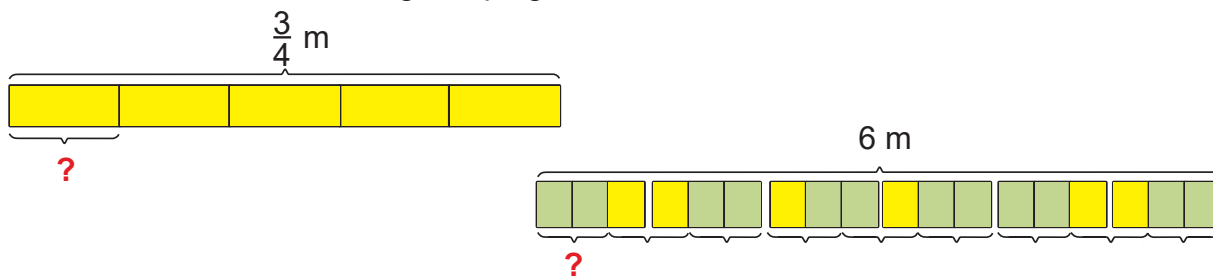

8. Sharlardagi amallarni bajarib, Abdullaning kiyimlariga mos ranglarni toping.

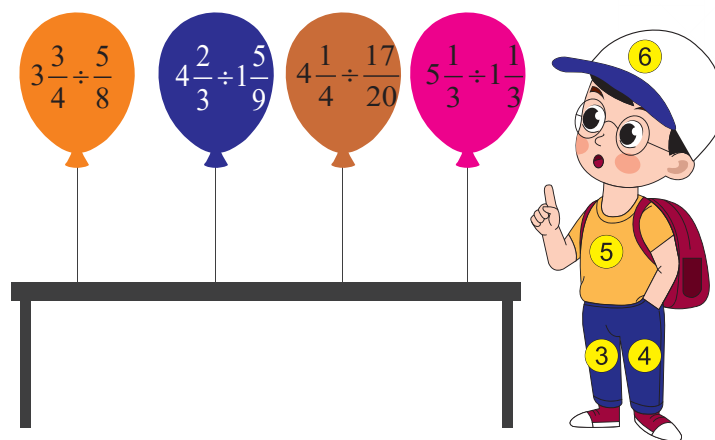

9. Ifodaning qiymatini toping:  $5\frac{1}{7} \div b$ , bunda  $b = 12; 48; \frac{9}{14}; \frac{18}{21}$ .

10\*. Tenglamani yeching.

a)  $x \times 5\frac{1}{6} = 62$

b)  $x \times 6\frac{2}{15} = 1\frac{8}{15}$

c)  $\frac{8}{9} \times x = 1\frac{1}{9}$

d)  $1\frac{6}{7} \times x = \frac{2}{3}$

11. Rasm asosida bo'lishga doir ifoda tuzing.

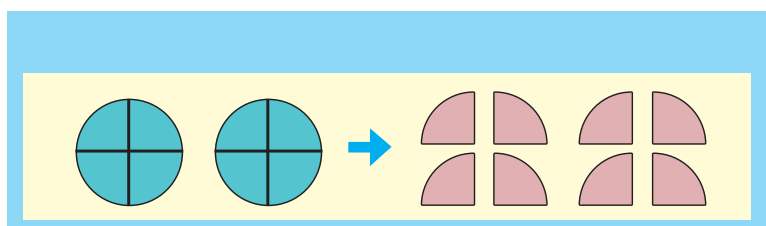

12. Yuzi  $5\frac{1}{4}$  m<sup>2</sup> bo'lgan to'g'ri to'rtburchakni yuzi  $\frac{1}{16}$  m<sup>2</sup> ga teng nechta kvadratlarga ajratish mumkin?
13. Velosipedchining tezligi  $11\frac{2}{5}$  km/h. U 19 km masofani necha soatda bosib o'tadi? 38 kilometrni-chi?

14. A, B va C harflarga mos keluvchi sonlarni toping.

$$\boxed{2\frac{2}{6}} \div \boxed{1\frac{2}{3}} \quad \boxed{\frac{7}{10}} \div \boxed{C}$$

$$\boxed{A} = \boxed{B}$$

15. Amallarni bajarib, natijani toping.

a)  $\left(12 \div 3\frac{3}{5} + \frac{2}{3}\right) \times \frac{2}{3}$

b)  $\left(\frac{19}{21} \div 1\frac{1}{21}\right) \div \left(\frac{38}{41} \div \frac{2}{41}\right)$

c)  $\left(13\frac{2}{7} - 5\frac{3}{14}\right) \div 2\frac{11}{51}$

d)  $\left(5\frac{1}{3} \div 3\frac{1}{5}\right) \div \left(6\frac{1}{2} \div 2\frac{1}{6}\right)$



**Mustaqil ish: 16–18.**

16. Jadvalni to'ldiring.

Misol	Bo'luvchiga teskari son	Bo'lishni ko'paytirishga almashtirish qadami	Bo'linma
$8 \div \frac{5}{6}$	?	$8 \times \frac{6}{5}$	?
$14 \div \frac{2}{3}$	?	$14 \times \frac{3}{2}$	?
$27 \div \frac{9}{13}$	$\frac{13}{9}$	?	?
$20 \div \frac{4}{77}$	$\frac{77}{4}$	?	?

17. Hisoblang.

a)  $6\frac{6}{9} \div 1\frac{5}{7}$

b)  $5\frac{5}{6} \div 7\frac{1}{6}$

c)  $7\frac{4}{5} \div 8\frac{1}{8}$

c)  $6\frac{1}{3} \div 1\frac{1}{18}$

d)  $9\frac{3}{4} \div 5\frac{2}{5}$

e)  $3\frac{7}{12} \div 4\frac{1}{2}$

18. Amallarni bajaring.

a)  $2\frac{2}{3} \div 1\frac{1}{7} \times 3\frac{3}{7} \times \frac{1}{4}$

b)  $\frac{3}{4} \times 1\frac{1}{7} \div \frac{2}{15} \times 12\frac{1}{4} \div 7\frac{1}{2}$

c)  $5\frac{5}{7} \div 2\frac{2}{5} \times 5\frac{1}{4} \div 1\frac{1}{6} \times \frac{2}{3}$

c)  $1\frac{8}{17} \times 3\frac{2}{5} \div \frac{11}{12} \times 2\frac{1}{5} \div \frac{4}{9}$

## QISMIGA KO'RA SONNI TOPISH



## Eslaymiz!

Bo'lish qanday bajarilgan?

$$150 \div \frac{1}{2} = \frac{150}{1} \div \frac{1}{2} = \frac{150}{1} \times \frac{2}{1} = \frac{300}{1} = 300$$



$\frac{1}{2}$  qismi 25 metrga teng bo'lgan kesmaning uzunligini toping.

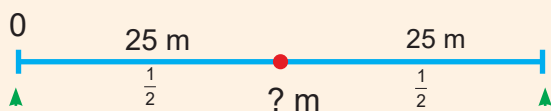

$$25 \div \frac{1}{2} = \frac{25}{1} \div \frac{1}{2} = \frac{25}{1} \times \frac{2}{1} = \frac{50}{1} = 50 \text{ m}$$



Qismiga ko'ra sonni topish uchun berilgan sonni qismni ifodalovchi kasrga bo'linadi.

$$a \div \frac{b}{c} = \frac{a}{1} \div \frac{b}{c} = \frac{a}{1} \times \frac{c}{b}$$



## Guruhlarda ishlaymiz: 1-4.

- Berilgan qismiga ko'ra sonlarni toping.
  - yarmi 70 ga teng
  - choragi 45 ga teng
  - nimchoragi 50 ga teng
  - $\frac{1}{2}$  qismi 50 ga teng
  - $\frac{1}{3}$  qismi 80 ga teng
  - $\frac{1}{5}$  qismi 40 ga teng
- Savollarga javob bering.
  - Qaysi sonning  $\frac{1}{5}$  qismi 10 ga teng?
  - Qaysi sonning  $\frac{1}{5}$  qismi 8 ga teng?
  - Qaysi sonning  $\frac{1}{9}$  qismi 7 ga teng?
  - Qaysi sonning  $\frac{2}{9}$  qismi 8 ga teng?
- Natijalarni taqqoslang.
  - Bir sonning  $\frac{4}{5}$  qismi 184 ga teng. Ikkinchi sonning  $\frac{12}{19}$  qismi 144 ga teng. Qaysi son katta?
  - Bir sonning  $\frac{5}{6}$  qismi 240 ga teng. Ikkinchi sonning  $\frac{20}{21}$  qismi 240 ga teng. Qaysi son katta? Qancha katta?
- To'g'ri to'rtburchak shaklidagi bog'ning 900 m<sup>2</sup> qismiga olma ko'chati ekilgan. Olmalar bog'ning  $\frac{18}{35}$  qismiga ekilgan bo'lsa, bog' necha m<sup>2</sup>?



### Mustahkamlash: 5–10.

5. Alisher o'zidagi pulning  $\frac{5}{8}$  qismiga kitob sotib oldi. Agar kitobning narxi 15 000 so'm bo'lsa, Alisherning qancha puli bo'lgan?
6. Noma'lum sonning  $\frac{2}{3}$  qismi 10 ga teng. Shu sonni toping.
7. Birinchi do'konda 1800 kg un sotildi. Bu shu do'konga keltirilgan unning  $\frac{12}{19}$  qismiga teng. Ikkinchi do'konda esa 1700 kg un sotildi. Bu shu do'konga keltirilgan unning  $\frac{34}{35}$  qismiga teng. Qaysi do'konga ko'p un keltirilgan?
8. Bolalar daryo bo'ylab sayohatga chiqishdi. Ular  $4\frac{4}{5}$  km yurishganidan so'ng hisoblab ko'rishsa, bosib o'tilgan yo'l jami yo'lning  $\frac{24}{35}$  qismini tashkil etar ekan. Ular daryo bo'ylab necha kilometr yo'l yurishni rejalashtirgan?
9. Qismga ko'ra sonlarni toping va natijalarni hisoblang.
  - a)  $\frac{7}{18}$  qismi 49 ga teng songa  $\frac{16}{21}$  qismi 64 ga teng sonni qo'shing.
  - b)  $\frac{2}{5}$  qismi 82 ga teng songa  $\frac{3}{4}$  qismi 99 ga teng sonni qo'shing.
  - c)  $\frac{5}{7}$  qismi 105 ga teng sondan  $\frac{4}{9}$  qismi 48 ga teng sonni ayiring.
  - d)  $\frac{3}{5}$  qismi 150 ga teng sondan  $\frac{7}{10}$  qismi 140 ga teng sonni ayiring.
10. Ahmad o'zidagi pulning  $\frac{5}{12}$  qismiga kitob,  $\frac{7}{18}$  qismiga katta daftar,  $\frac{5}{36}$  qismiga ruchka sotib oldi. Agar ruchka 5000 so'm bo'lsa, Ahmadning qancha puli bo'lgan? Ahmadning qancha puli qolgan?



### Mustaqil ish: 11–12.

11. Komil bobo nabiralariga bir nechta daftar olib keldi. Katta nabirasiga jami daftarlarning  $\frac{3}{7}$  qismini, o'rtanchasiga  $\frac{5}{14}$  qismini, qolgan 9 ta daftarni esa kichik nabirasiga berdi. Komil bobo nechta daftar olib kelgan?
12. Qotishmaning  $\frac{3}{8}$  qismi misdan,  $\frac{5}{12}$  qismi qalaydan va  $\frac{5}{24}$  qismi qo'rg'oshindan iborat. Agar qotishmadagi qo'rg'oshin 250 gramm bo'lsa, qotishmaning og'irligini toping. Qotishmada qancha mis va qancha qalay bor?

## KASRLAR USTIDA TOPSHIRIQLAR

1. Hisoblang.

$$a) \frac{15}{10} + \frac{16}{20} - \frac{12}{8}$$

$$b) \frac{17}{21} + \frac{19}{42} - \frac{12}{63}$$

$$c) \frac{2}{3} + 1\frac{1}{2} - \frac{1}{4}$$

$$d) 1\frac{4}{5} - \frac{3}{4} + \frac{7}{10}$$

$$e) \left(\frac{3}{6} - \frac{1}{4}\right) + \left(\frac{1}{2} - \frac{1}{3}\right)$$

$$f) \left(1\frac{3}{5} - \frac{3}{10}\right) + \left(\frac{1}{4} - \frac{1}{8}\right)$$

2. Ifodalarning qiymatini toping.

$$a) \frac{3}{2} - \frac{1}{2} \div \frac{3}{5} + 1\frac{1}{4} \times \frac{1}{3}$$

$$b) \left(\frac{5}{6} \div 3\frac{1}{3}\right) \div \left(\frac{1}{2} + 1\right)$$

$$c) \left(\frac{3}{2} + \frac{1}{2}\right) \times \frac{3}{4} + \left(\frac{1}{5} + \frac{2}{5}\right) \div \frac{4}{15}$$

$$d) \frac{5}{11} \div \frac{15}{22} \times 1\frac{1}{2}$$

$$e) \left(3\frac{3}{4} \div 6\frac{2}{3}\right) - \left(\frac{1}{3} \div 1\frac{1}{3}\right)$$

$$f) \frac{7}{10} + \left(1\frac{1}{3} - \frac{2}{9}\right) \div 1\frac{1}{9} + 2\frac{1}{2} \times \left(\frac{1}{3} + \frac{1}{6}\right)$$

3. O'quvchilar matematika fanidan yozma ish yozishdi. Ularning  $\frac{1}{8}$  qismi a'lo,  $\frac{1}{4}$  qismi yaxshi,  $\frac{1}{2}$  qismi qoniqarli va qolgan 4 o'quvchi qoniqarsiz baho oldi. Nechta o'quvchi yozma ish yozgan? Nechtadan o'quvchi a'lo, yaxshi va qoniqarli baho olgan?

4. Sinfda 48 nafar o'quvchining  $\frac{1}{4}$  qismi matematika to'garagiga,  $\frac{3}{8}$  qismi ingliz tili to'garagiga,  $\frac{5}{16}$  qismi fizika to'garagiga qatnaydi. Agar har bir o'quvchi bittadan fan to'garagiga kirishi ma'lum bo'lsa, nechta o'quvchi uchala fan to'garagiga kirmaydi?

5. Madina  $6\frac{2}{3}$  ni  $5\frac{1}{4}$  ga ko'paytirishni, Muslima esa  $6\frac{2}{3}$  ni  $3\frac{3}{4}$  ga ko'paytirishni bajardi. Muxlisa dugonalarining natijalarini qo'shdi. Muxlisa qanday sonni hosil qilgan?

6. Bo'sh kataklarni to'ldiring.

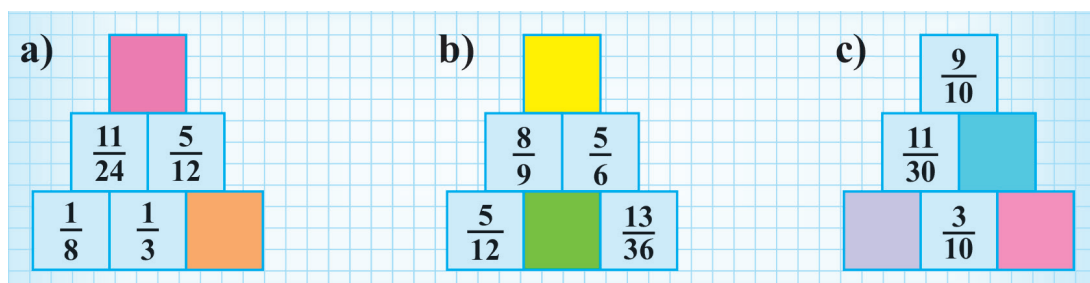

7. Ahmad  $10\frac{3}{5}$  ni  $9\frac{3}{17}$  ga ko'paytirishni, Avaz esa  $4\frac{3}{17}$  ni  $10\frac{3}{5}$  ga ko'paytirishni bajardi. Komil Ahmadning natijasidan Avazning natijasini ayirdi. Komilning natijasini toping.
8. Akmal  $8\frac{7}{13}$  ni  $6\frac{3}{5}$  ga ko'paytirishni, Aziz esa  $8\frac{7}{13}$  ni  $6\frac{2}{5}$  ga ko'paytirishni bajardi. Akbar do'stlarining natijalarini qo'shdi. Akbar qanday sonni hosil qilgan.
9. Hisoblang.
- a)  $45 \times \left(2\frac{3}{5} + 4\frac{11}{15}\right)$                       b)  $38 \times \left(2\frac{3}{19} + 2\frac{3}{38}\right)$
- c)  $105 \times \left(5\frac{2}{3} - 2\frac{5}{15}\right)$                       d)  $85 \times \left(17\frac{5}{17} - 6\frac{37}{85}\right)$
- e)  $\left(1 - \frac{1}{10}\right) + \left(1 - \frac{2}{5}\right) \div \frac{1}{5}$                       f)  $\frac{3}{4} \times \frac{4}{5} \times \frac{5}{6} \times \frac{6}{7} \times \frac{7}{8} \times \frac{8}{9}$
10. To'g'ri to'rtburchakning bo'yi  $5\frac{5}{13}$  dm, eni esa undan  $2\frac{7}{13}$  dm qisqa. To'g'ri to'rtburchakning perimetrini toping.
11. Sayyoh  $9\frac{1}{7}$  km yo'l bosdi. Bu masofa butun yo'lning  $\frac{3}{7}$  qismini tashkil etadi. Sayyoh yana necha kilometr masofani bosib o'tishi kerak?
12. Taksoparkda 64 ta avtomobil bor. Dushanba kuni haydovchilarning  $\frac{3}{4}$  qismi buyurtma qabul qildi. Necha avtomobil buyurtma qabul qilgan?
13. Bir kunda  $3\frac{1}{4}$  km uzunlikdagi yo'l ta'mirlandi. Shunday ishlansa, 8 kunda qancha yo'l ta'mirlanadi?
14. Ifodaning qiymatini toping.
- a)  $2 \times \frac{1}{3} \div 6 + \frac{2}{3} - \frac{5}{18} \div 2\frac{1}{2}$                       b)  $\left(85\frac{1}{3} - 84\frac{1}{4}\right) \div \frac{1}{12}$
- c)  $\left(1 + \frac{1}{2}\right) \times \left(1 + \frac{1}{3}\right) \times \left(1 + \frac{1}{4}\right) \times \left(1 + \frac{1}{6}\right) \times \left(1 + \frac{1}{7}\right) \times \left(1 + \frac{1}{8}\right) \times \left(1 + \frac{1}{9}\right)$
- d)  $2 \div \left(1 + \left(\frac{1}{2} + 1\right) \div 1\frac{1}{3}\right)$
15. Sonning  $\frac{4}{7}$  qismidan uning  $\frac{1}{4}$  qismi ayrilgan edi, natija 18 ga teng bo'ldi. Shu sonni toping.

**16.** Sonning qismini toping va amallarni bajaring.

1) 6300 ning  $\frac{5}{9}$  qismiga  $\frac{2}{3}$  qismi 400 ga teng bo'lgan sonni qo'shing.

2) 6000 ning  $\frac{3}{4}$  qismidan  $\frac{3}{5}$  qismi 900 ga teng bo'lgan sonni ayiring.

**17.** Qismga ko'ra sonni toping va amallarni bajaring.

1)  $\frac{5}{7}$  qismi 200 ga teng bo'lgan sonni 360 ning  $\frac{4}{15}$  qismiga teng sonni ko'paytiring.

2)  $\frac{11}{16}$  qismi 484 ga teng bo'lgan sonni 242 ning  $\frac{4}{11}$  qismiga teng songa bo'ling.

**18.** Ikkita chavandoz bir-biriga qarab ikki qishloqdan bir vaqtda yo'lga chiqdi. Birinchi chavandoz  $\frac{2}{3}$  soatda 12 km, ikkinchisi  $\frac{3}{4}$  soatda 15 km yo'l yurdi. Agar ular  $2\frac{1}{2}$  soatdan keyin uchrashgan bo'lsa, qishloqlar orasidagi masofani toping.

**19.** Misollarni ketma-ket, bir-biriga bog'liq holda yeching.

$$1) \frac{2}{3} \times \frac{3}{4} + \frac{1}{3} \times \frac{3}{4} = \bullet$$

$$2) \bullet \times 1\frac{2}{5} + 1\frac{2}{5} \times 4\frac{1}{4} = \blacktriangle$$

3) Sarvar 35 sonining  $\frac{1}{\blacktriangle}$  qismini topdi va  $\blacksquare$  natijaga erishdi.  $\blacksquare$  sonini toping.

**20.** Sayyoh butun yo'lning  $\frac{7}{20}$  qismini o'tgach, manzilgacha 52 km qolgani ma'lum bo'ldi. Sayyoh necha kilometr yo'l yurgan?

**21.** Sayyoh butun yo'lning  $\frac{5}{14}$  qismini yurdi. Hisoblasa, qolgan yo'l bosib o'tgan yo'lidan 24 km ko'p ekan. Sayyoh yana qancha yo'l yurishi kerak?

**22.** 49 sonining  $\frac{3}{7}$  qismi qaysi sonning  $\frac{7}{11}$  qismiga teng?

**23.** 18 kg tuz  $\frac{3}{4}$  kg dan qilib xaltachalarga solindi. Necha xaltacha kerak bo'lgan?

**24.** Do'konga bir nechta qopda shakar keltirildi. Birinchi kuni  $\frac{4}{9}$  qismi, ikkinchi kuni  $\frac{2}{5}$  qismi sotildi. Shundan so'ng do'konda 14 qop shakar qoldi. Dastlab do'konga necha qop shakar keltirilgan?

**25\***. Elbek o'zidagi yong'oqlarning  $\frac{1}{3}$  qismini Alisherga, qolgan yong'oqlarning  $\frac{1}{3}$  qismini Dilyorga, qolgan yong'oqlarning  $\frac{1}{3}$  qismini Javlonga berdi. O'zida esa 8 ta yong'oq qoldi. Elbekda qancha yong'oq bo'lgan?

**26\***. Kitobning birinchi bo'limi uning  $\frac{5}{13}$  qismini, ikkinchi bo'limi esa  $\frac{2}{13}$  qismini tashkil etadi. Agar birinchi bo'lim ikkinchi bo'limdan 45 bet ko'p bo'lsa, kitob necha betdan iborat?

**27\***. To'g'ri to'rtburchakning eni 48 dm ga teng bo'lib, u perimetrning  $\frac{3}{16}$  qismini tashkil etadi. To'g'ri to'rtburchakning bo'yi va perimetrini toping.

**28\***. Hisoblang.

$$a) \left(\frac{1}{2} + \frac{3}{4}\right) + \left(\frac{5}{6} + \frac{5}{8}\right) + \left(1\frac{1}{2} + 1\frac{1}{4}\right) + \left(1\frac{1}{6} + 1\frac{3}{8}\right) - 5\frac{1}{6}$$

$$b) 4 + \left(\frac{3}{4} + \frac{2}{3} + \frac{1}{2}\right) + \left(\frac{5}{6} + \frac{4}{5} + \frac{6}{7}\right) + \left(\frac{1}{2} + \frac{1}{3} + \frac{1}{4}\right) + \left(\frac{1}{5} + \frac{1}{6} + \frac{1}{7}\right) - 2\frac{97}{2017}$$

$$c) 1\frac{4}{5} \div \left( \left( 4\frac{2}{5} \times 6\frac{1}{3} - 5\frac{19}{21} \div \frac{5}{22} \right) \times \frac{5}{22} \right)$$

$$d) \frac{1}{2 \times 3} + \frac{1}{3 \times 4} + \frac{1}{4 \times 5} + \frac{1}{5 \times 6} + \frac{1}{6 \times 7} + \frac{1}{7 \times 8} + \frac{1}{8 \times 9} + \frac{1}{9 \times 10} + \frac{1}{10 \times 11} + \frac{1}{11 \times 12}$$

$$e) \frac{1 \times 2 \times 3 + 3 \times 6 \times 9 + 5 \times 10 \times 15}{2 \times 4 \times 6 + 6 \times 12 \times 18 + 10 \times 20 \times 30}$$

$$f) \frac{2}{1 + \frac{1}{1 + \frac{1}{2}}} - \frac{2}{1 + \frac{1}{1 - \frac{1}{2}}}$$

$$g) 1\frac{7}{15} \times 1\frac{4}{11} + 2\frac{8}{17} \div 1\frac{8}{34} - \frac{1}{2} \div \left( 1\frac{2}{3} - 1\frac{1}{6} \right)$$

$$h) 8\frac{1}{7} \div 1\frac{5}{14} + 11 \div \left( 2\frac{3}{4} - 1\frac{3}{8} \right) - 3 \times \left( 1\frac{4}{5} + 1\frac{1}{5} \right)$$



29\*. Tenglamani yeching.

$$a) \left(2\frac{4}{5} \times x - 50\right) \div \frac{2}{3} = 51$$

$$b) \left(4\frac{1}{2} - 2x\right) \times 3\frac{2}{3} = \frac{11}{15}$$

$$c) 2\frac{3}{5} \div \left(x + 1\frac{3}{14}\right) - 1\frac{2}{5} = \frac{1}{3}$$

$$d) \left(x - \frac{3}{8}\right) \times \frac{8}{35} + 2\frac{2}{7} = 2\frac{3}{5}$$

30. Hisoblang.

$$a) \frac{15}{20} + \frac{42}{30} - \frac{56}{40}$$

$$b) \left(\frac{1}{2} - \frac{1}{3}\right) + \left(\frac{1}{3} - \frac{1}{4}\right)$$

$$c) \frac{3}{8} \times \frac{4}{9} \div \frac{1}{3}$$

$$d) \left(1\frac{4}{5} + 2\frac{9}{10} - 2\frac{17}{20}\right) \div \frac{13}{20} + 2\frac{3}{5} \times 1\frac{2}{13}$$

33. Kitobning narxi 18000 so'm edi. Uning narxi  $\frac{1}{18}$  qismicha arzonlashdi. Ma'lum vaqtdan so'ng yangi narxining  $\frac{1}{10}$  qismicha qimmatlashdi. Kitobning hozirgi narxi qancha bo'ldi?

31. Hisoblang.

$$a) 63 \times \left(3\frac{5}{21} + 4\frac{1}{3}\right)$$

$$c) \left(\left(3 - \frac{1}{2}\right) + \left(2 - \frac{1}{3}\right)\right) \div \left(\left(1 - \frac{1}{4}\right) + \left(2 - \frac{1}{4}\right)\right)$$

$$b) 52 \times \left(19\frac{10}{13} - 17\frac{19}{26}\right)$$

$$d) 1\frac{1}{2} \times 1\frac{1}{3} \times 1\frac{1}{4} \times 1\frac{1}{5} \times 1\frac{1}{6} \times 1\frac{1}{7}$$

32. To'g'ri to'rtburchakning bo'yi  $6\frac{3}{5}$  cm, eni esa bo'yidan  $2\frac{1}{5}$  cm qisqa. Uning perimetrini toping.

33. Ma'mura opaning yoshi 40 da. Qizining yoshi onasi yoshining  $\frac{3}{10}$  va buvisi yoshining  $\frac{6}{31}$  qismini tashkil etadi. Buvining yoshini toping.

34. So'roq belgisi o'rniga qaysi son mos keladi?

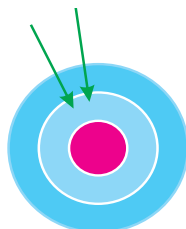

14

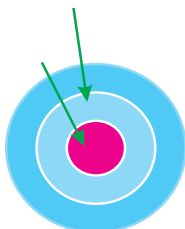

16

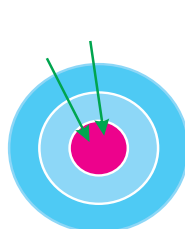

?

# III bob

## O'NLI KASRLARNI KO'PAYTIRISH VA BO'LISH

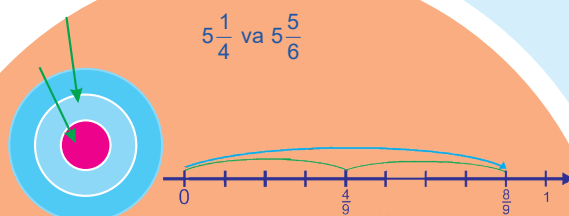

$$\frac{4}{5} \times \left( \frac{15}{16} + \frac{20}{64} \right) = \left( \frac{4}{5} \times \frac{15}{16} \right) + \left( \frac{4}{5} \times \frac{20}{64} \right) = \frac{3}{4} + \frac{4}{16} = \frac{12+4}{16} = \frac{16}{16} = 1$$

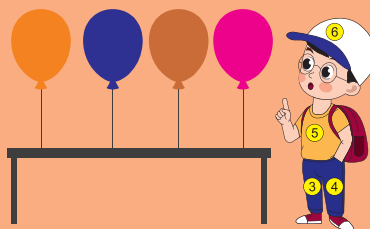

## O'NLI KASRNI NATURAL SONGA KO'PAYTIRISH



Eslaymiz!

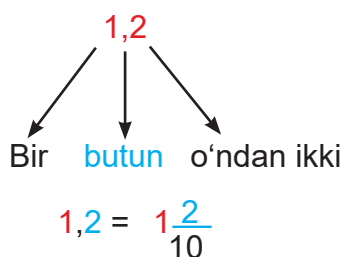

$$1\frac{1}{5} = 1\frac{1 \times 2}{5 \times 2} = \frac{2}{10} = 1,2$$

$$1,2 + 1,2 + 1,2 + 1,2 = ?$$



O'qli kasrdagi vergulga e'tibor bermay, natural sonlarni ko'paytirish qoidasiga rioya qilinadi.

O'qli kasrning kasr qismidagi raqamlar nechta bo'lsa, natijaning o'ng tomonidan shuncha raqam ajratilib, vergul qo'yiladi.

$$\begin{array}{r} 4 \\ \times 1,2 \\ \hline 4,8 \end{array}$$

Jami verguldan keyingi raqamlar soni

0 ta raqam

+ 1 ta raqam

1 ta raqam



Guruhlarda ishlaymiz: 1-6.

1. Hisoblang.

a)  $\begin{array}{r} 30,5 \\ \times 3 \\ \hline \end{array}$

b)  $\begin{array}{r} 8,8 \\ \times 7 \\ \hline \end{array}$

c)  $\begin{array}{r} 15,14 \\ \times 15 \\ \hline \end{array}$

d)  $\begin{array}{r} 17,25 \\ \times 11 \\ \hline \end{array}$

2. Ko'paytmalarni toping.

a)  $5 \times 0,21$

b)  $8,1 \times 4$

c)  $5,05 \times 10$

d)  $12 \times 8,8$

e)  $127 \times 15,8$

f)  $27,9 \times 12$



O'qli kasr kasr ko'rinishiga keltiriladi, kasrlarni natural songa ko'paytirish qoidasiga rioya qilinadi.

$$1,3 \times 8 = \frac{13}{10} \times 8 = \frac{13 \times 8}{10} = \frac{104}{10} = 10,4$$

$$2,13 \times 3 = \frac{213}{100} \times 3 = \frac{213 \times 3}{100} = \frac{639}{100} = 6,39$$

3. Bo'sh kataklarni to'ldiring.

$$a) 0,45 \times 5 = \frac{\square}{100} \times \square = \frac{\square \times \square}{100} = \frac{\square}{100} = \square, \square$$

$$b) 1,4 \times 6 = \frac{\square}{\square} \times \square = \frac{\square \times \square}{\square} = \frac{\square}{\square} = \square, \square$$

4. Hisoblang.

a)  $12,2 \times 99$

b)  $27,1 \times 8$

c)  $12,5 \times 82$

d)  $99 \times 0,99$

e)  $77,7 \times 33$

f)  $41,1 \times 2$

5. Stol tennisining to'pi 2,73 g massaga ega. 8 ta stol tennis to'pining massasi qancha?

6. Futbol maydoni uchun 2 ta darvoza yasash kerak. Darvoza o'lchamlari: uzunligi 7,32 m va bo'yi 2,44 m. Ustaga jami necha metr truba kerak bo'ladi?



### Mustahkamlash: 7–17.

7. Hisoblang.

a)  $2 \times 0,99$

b)  $3 \times 8,9$

c)  $5 \times 0,82$

d)  $9 \times 0,91$

e)  $7 \times 0,33$

f)  $5 \times 0,2$

8. Natijalarga vergulni to'g'ri qo'yamiz.

a)  $7,1 \times 5 = 355$

b)  $3,12 \times 6 = 1872$

c)  $15,466 \times 3 = 46398$

d)  $1,408 \times 5 = 7040$

e)  $2,005 \times 8 = 16040$

f)  $8,25 \times 4 = 3300$

Hisoblash to'g'ri bajarilganmi?

$$15 \times 6,5 = 15 \times (6 + 0,5) = \\ = (15 \times 6) + (15 \times 0,5) = 90 + 7,5 = 97,5$$

9. 5 ta yashil qutida 1,26 kg, 6 ta qizil qutida esa 1,026 kg shakar bor. Qaysi qutida ko'proq shakar bor?

10. Maydonlarning har birining yuzasini hisoblang. Qanday munosabat mavjud?

a)  $82 \times 5,3$

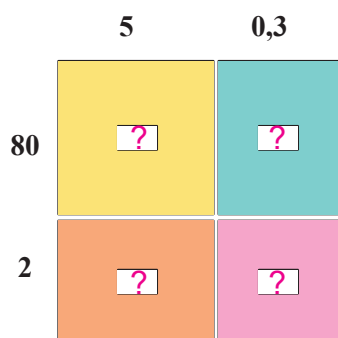

b)  $54 \times 3,2$

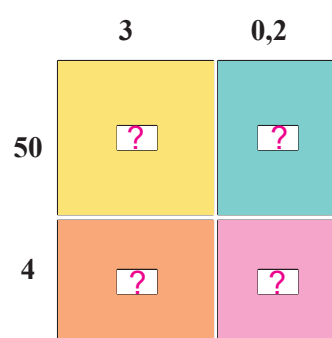

11. Berilgan to'g'ri to'rtburchaklarning yuzini toping.

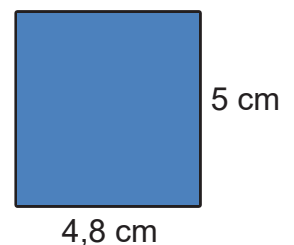
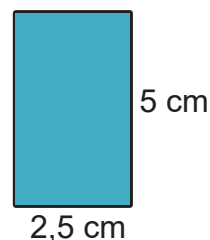
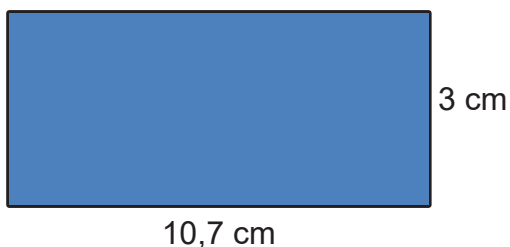

12. Bir dona ustun qurish uchun 7,84 qop sement va 14,3 metr temir kerak bo'ladi. 12 ta beton ustun uchun qancha sement va temir kerak bo'ladi?
13. Bir dona beton ustunini 3,5 soat ichida qurish mumkin. Xuddi shunday 12 ta beton ustunni quruvchilar jamoasi necha soat ichida bitiradi?
14. Bir dona beton ustun o'lchamlari 0,5×0,5×4 metr bo'lsa, 12 ta ustun hajmi qancha bo'ladi? 1 m<sup>3</sup> beton ustunni qurish narxi 75 000 so'm bo'lsa, jami ustunlar uchun qancha pul sarflanadi?

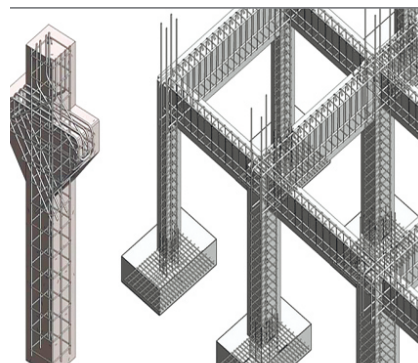

15. Chap tomonda joylashgan sonlarni 2 ga ko'paytirib, moslarini belgilang.

2,3	18,2	5,2	18,8
7,5	15	6,7	13,4
1,8	6,8	8,9	18,8
4,6	4,6	2,7	10,4
9,1	9,2	6,2	12,4
3,4	3,6	9,4	5,4

16. O'nli kasrlarni ustun shaklida ko'paytiring.

- a)  $0,5 \times 4$       b)  $3,5 \times 2$       c)  $4 \times 0,15$       d)  $0,4 \times 1,16$   
 e)  $0,7 \times 8$       f)  $2,3 \times 4,5$       g)  $2,85 \times 4$       h)  $3,012 \times 15$   
 i)  $104 \times 2,75$       j)  $3,41 \times 101$       k)  $3,8 \times 5$       l)  $11,12 \times 1,1$

17. Bo'sh kataklar o'rniga qaysi raqamlar mos keladi?

$\begin{array}{r} \boxed{4} \boxed{4} \\ \times \quad \boxed{\phantom{0}} \\ \hline 17,6 \end{array}$	$\begin{array}{r} \boxed{5} \boxed{8} \\ \times \quad \boxed{\phantom{0}} \\ \hline 52,2 \end{array}$	$\begin{array}{r} \boxed{3} \boxed{2} \\ \times \quad \boxed{\phantom{0}} \\ \hline 19,2 \end{array}$	$\begin{array}{r} \boxed{2} \boxed{6} \\ \times \quad \boxed{\phantom{0}} \\ \hline 15,6 \end{array}$	$\begin{array}{r} \boxed{\phantom{0}} \boxed{\phantom{0}} \\ \times \quad \boxed{9} \\ \hline 19,8 \end{array}$	$\begin{array}{r} \boxed{4} \boxed{\phantom{0}} \\ \times \quad \boxed{3} \\ \hline 13,5 \end{array}$	$\begin{array}{r} \boxed{3} \boxed{9} \\ \times \quad \boxed{\phantom{0}} \\ \hline 1 \boxed{\phantom{0}},6 \end{array}$
---	---	---	---	---	---	--



### Mustaqil ish: 18.

18. "?" belgisi o'rniga mos sonlarni qo'ying.

	10	10,2
10	100	?
3	30	?

	0,4	1,07
8		?
?		?

## O'NLI KASRNI 10 GA, 100 GA, 1000 GA KO'PAYTIRISH



Eslaymiz!

Ko'paytirish  
qanday bajarilganini  
tushuntiramiz.

$$1,45 \times 10 = \frac{\square}{100} \times 10 = \frac{\square \times \square}{100} = \frac{145}{\square} = 14,5$$

$$1,457 \times 100 = \frac{1457}{1000} \times 100 = \frac{1457 \times \square}{\square} = \frac{1457}{\square} = 145,7$$



O'nli kasrni 10, 100, 1000 ga ko'paytirish uchun:

$$3,25 \times 10 = 32,5$$

10 sonida 1 ta nol borligi uchun vergul o'ngga bir xona siljiriladi;

$$3,25 \times 100 = 325$$

100 sonida 2 ta nol borligi uchun vergul o'ngga ikki xona siljiriladi;

$$3,25 \times 1000 = 3250$$

1000 sonida 3 ta nol borligi uchun vergul o'ngga uch xona siljiriladi.



Guruhlarda ishlaymiz: 1-3.

1. Jadvalni to'ldiring.

×	0,5	2,12	0,02	14,4	8,008	54,1	0,7	4,45	5,741
10									
100									
1000									

2. Yetishmayotgan sonlarni toping.

a)  $1000 \times \underline{\quad} = 26280$

b)  $\underline{\quad} \times 90,3 = 903$

c)  $10 \times \underline{\quad} = 395$

d)  $\underline{\quad} \times 90,6 = 906$

e)  $81,26 \times \underline{\quad} = 81260$

f)  $\underline{\quad} \times 77,6 = 77600$

3. Modellar asosida hisoblang.

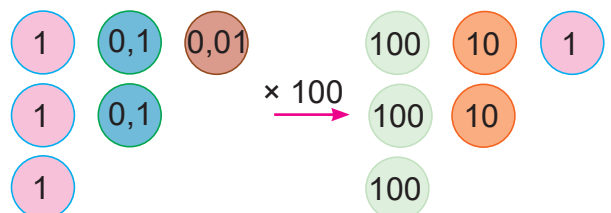
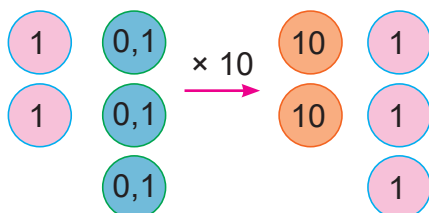



### Mustahkamlash: 4–8.

4. Fermer xo'jaligidagi 5,6 ha yer maydoniga bodring ko'chatlari ekilgan. Pomidor ko'chatlari uchun 4,35 ha ajratilgan va qolgan maydon bo'sh. Fermer jami 12,56 ha yerga egalik qilsa, ekilmagan yer maydoni qancha?

5. Sonlarni avval 10 ga ko'paytiring, keyin esa o'sib borish tartibida yozing.

a) 4,56; 4,39; 8,79; 3,3                      b) 4,14; 0,27; 97,2; 99,6

c) 5,54; 46,5; 9,23; 4,16                      d) 97,1; 67,5; 2,13; 6,21

6. Hisoblang.

a)  $0,5 \times 10$

b)  $3,5 \times 10$

c)  $10 \times 0,15$

d)  $10 \times 1,16$

e)  $0,7 \times 100$

f)  $2,3 \times 100$

g)  $2,85 \times 100$

h)  $3,012 \times 100$

i)  $1\ 000 \times 2,75$

j)  $3,41 \times 1\ 000$

k)  $3,8 \times 1\ 000$

l)  $11,12 \times 1\ 000$

7. Hisoblang.

$$\begin{array}{r} 30,5 \\ \times 10 \\ \hline \end{array}$$

$$\begin{array}{r} 2,05 \\ \times 10 \\ \hline \end{array}$$

$$\begin{array}{r} 170,05 \\ \times 100 \\ \hline \end{array}$$

$$\begin{array}{r} 84,84 \\ \times 1000 \\ \hline \end{array}$$

8. Hisoblang.

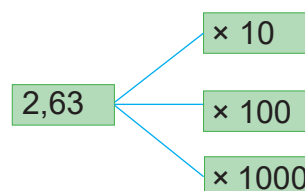
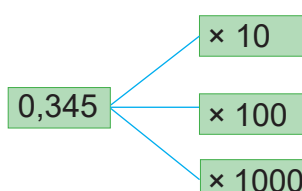
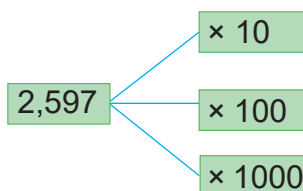

### Mustaqil ish: 9–11.

9. Moslarini belgilang.

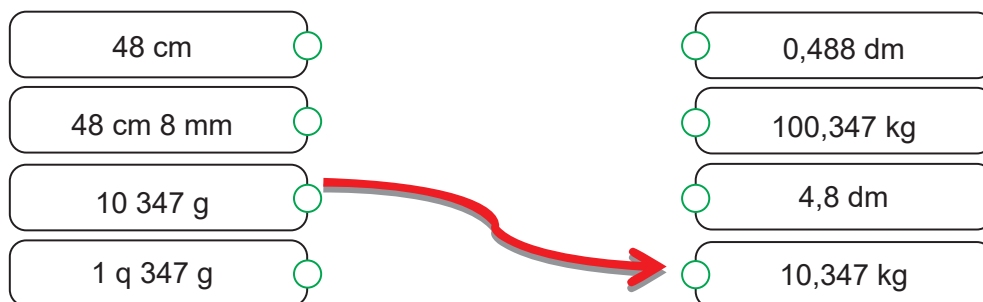

10. Hisoblang.

a)  $2,5 \times 10$

b)  $33,7 \times 10$

c)  $10 \times 0,10$

d)  $10 \times 1,5$

e)  $0,07 \times 100$

f)  $20,3 \times 100$

g)  $0,01 \times 100$

h)  $21,02 \times 100$

11. Bo'sh kataklarni to'ldiring.

0,5	×		=	5
×		×		×
	×	5,5	=	
=		=		=
50	×	55	=	

10	×	1,7	=	
×		×		×
	×		=	
=		=		=
27	×	17	=	



O'nli kasrlardagi vergulga e'tibor bermay, natural sonlarni ko'paytirish qoidasiga rioya qilinadi.

O'nli kasrlarning kasr qismidagi raqamlar nechta bo'lsa, natijaning o'ng tomonidan shuncha raqam ajratilib, vergul qo'yiladi.

Verguldan keyingi jami raqamlar soni

$$\begin{array}{r} 3,77 \rightarrow 2 \text{ ta raqam} \\ \times 2,8 \rightarrow 1 \text{ ta raqam} \\ \hline 3016 \\ + 754 \\ \hline 10,556 \rightarrow 3 \text{ ta raqam} \end{array}$$



### Guruhlarda ishlaymiz: 1-4.

#### 1. Hisoblang.

a)  $6,3 \times 2,5$

b)  $9,7 \times 4,8$

c)  $5,96 \times 2,5$

d)  $3,6 \times 8,3$

e)  $32,8 \times 7,3$

f)  $42,9 \times 5,6$

g)  $87,3 \times 5,3$

h)  $18,72 \times 9,6$

#### 2. Hisoblang.

a) 
$$\begin{array}{r} 3,50 \\ \times 2,5 \\ \hline \end{array}$$

b) 
$$\begin{array}{r} 2,6 \\ \times 1,2 \\ \hline \end{array}$$

c) 
$$\begin{array}{r} 3,4 \\ \times 2,4 \\ \hline \end{array}$$

d) 
$$\begin{array}{r} 7,5 \\ \times 2,3 \\ \hline \end{array}$$

#### 3. Shakllarning yuzi va perimetrini toping.

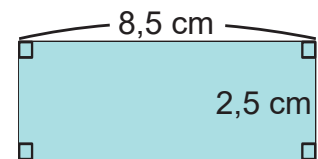
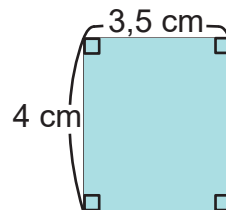
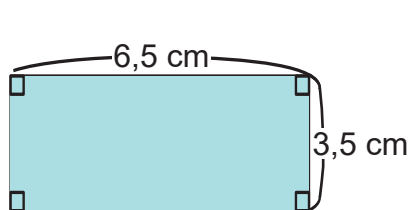

#### 4. Mevalarning umumiy massasi qancha?

Jami			
? kg	10,5 kg	 dan 2,5 marta ko'p	 dan 2 marta ko'p



### Mustahkamlash: 5-19.

#### 5. Namuna asosida ko'paytirishlarni bajaring.

$$0,4 \times 0,09 = \frac{4}{10} \times \frac{9}{100} = \frac{4 \times 9}{10 \times 100} = \frac{36}{1000} = 0,036$$

a)  $0,08 \times 0,05$

b)  $0,006 \times 0,31$

c)  $0,007 \times 0,5$

d)  $0,009 \times 0,78$

e)  $0,05 \times 0,5$

f)  $0,700 \times 0,05$



6. Mutaxassislarning hisob-kitobiga ko'ra, dunyo aholisi soni yildan yilga ko'payib, 2100-yilda 11,2 mlrd ga yetadi.

1. Qaysi yillar oralig'ida aholi soni eng yuqori darajada ko'payadi?
2. 1990-yildan 2100-yilgacha aholi soni qanchaga ko'payadi?
3. Rasm asosida ustunli diagramma tuzing.

Dunyo aholisi	
1990	5,3 mlrd
2015	7,3 mlrd
2030	8,5 mlrd
2050	9,7 mlrd
2100	11,2 mlrd

7. A va B shaharlar orasidagi masofa qancha?

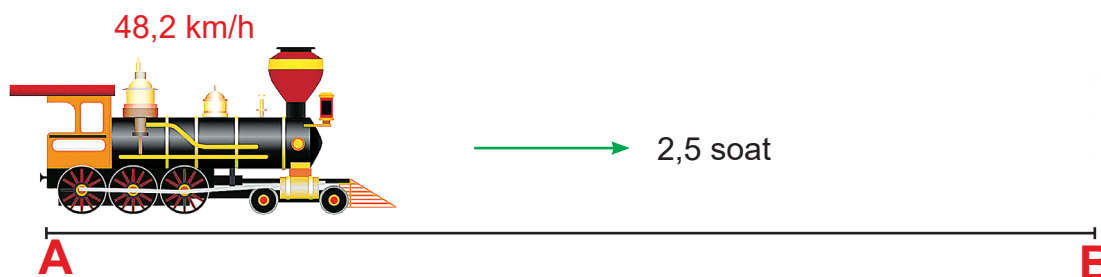

8. Ko'paytmalarni bajarung.

- a)  $0,03 \times 0,03$       b)  $0,8 \times 0,8$       c)  $0,03 \times 0,8$   
d)  $0,08 \times 0,4$       e)  $0,5 \times 0,01$       f)  $0,08 \times 0,3$

9. Ifodani ko'paytma shaklida tasvirlang va natijani toping.

- a)  $3,6k + 1,4k$ ;  $k = 4$       b)  $15,8y + 9,2y$ ;  $y = 8$   
c)  $24,52x - 15,42x$ ;  $x = 1,2$       d)  $5,8a - 0,8a$ ;  $a = 0,8$

10. Meva sotuvchisi 23,5 kg mango, 67,25 kg tarvuz, 12,75 kg qulupnay va 56,25 kg apelsin soddi. Dastlab mevalari 185,75 kg bo'lsa, sotuvchida qancha meva qoldi?

**!** Ko'paytirish xossalari

1)  $3,4 \times 2,1 = 2,1 \times 3,4 = 7,14$   
2)  $0,5 \times 6,7 \times 4 = (0,5 \times 4) \times 6,7 = 13,4$   
3)  $2,5 \times 8,7 + 0,5 \times 8,7 = (2,5 + 0,5) \times 8,7 = 26,1$

11. Qulay usulda hisoblang.

- a)  $3,4 \times 1,6 + 2,3 \times 1,6 + 4,3 \times 0,7 + 4,3 \times 0,9$   
b)  $5,6 \times 3,8 + 5,6 \times 1,6 + 2,7 \times 4,6 + 2,9 \times 4,6$   
c)  $0,7 \times 2,3 - 0,7 \times 1,5 + 0,8 \times 1,2 - 0,8 \times 0,5$   
d)  $6,5 \times 2,5 - 1,6 \times 6,5 + 0,9 \times 0,7 + 0,8 \times 0,9$

12. Shakllarning perimetrini toping.

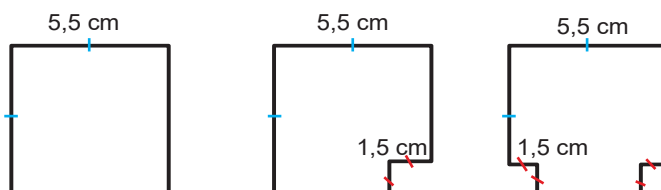

**!** Pul munosabatlari

$$5\ 500 \text{ so'm} = 5000 + 500 = \frac{5000}{1000} + \frac{500}{1000} = 5 + 0,5 = 5,5 \text{ ming so'm}$$

$$78,5 \text{ ming so'm} = 78,5 \times 1000 = 78\ 500 \text{ so'm}$$

- 13.** Quruvchi soatiga 45,0 ming so'mga ishlaydi, lekin u tushlik vaqti uchun pul olmaydi. U tushlikkacha 3,5 soat, 1 soatli tushlikdan keyin 4,5 soat ishladi. Quruvchi 1 kunda qancha pul oladi?
- 14.** 1 kg "Alanga" guruchining narxi 13,5 ming so'm. 17,5 kg shunday guruchning narxini toping.
- 15.** Malika mahalladagi do'kondan 5 quti sut sotib oldi. Sutning har bir qutisi narxi 5,50 ming so'mni tashkil qiladi. Malika sut sotib olish uchun qancha pul sarfladi?
- 16.** Karim Milliy kutubxonada yordamchi sifatida ishlaydi. U soatiga 9,75 ming so'm pul oladi. Agar haftasiga 40 soat ishlasa, u 1 haftada qancha pul oladi?
- 17.** Agar 1 m matoning narxi 33,90 ming so'm bo'lsa, 47,2 m matoning narxini toping.
- 18.** Shuhrat 290,5 ming so'mga sumka sotib oldi. U sotuvchiga 100 ming so'mlik 3 ta banknota berdi. U qancha qaytim oladi?
- 19.** Ko'paytirishni bajarib, jadvalni to'ldiring.
- a)  $0,6 \times 10$       b)  $15,9 \times 10$       c)  $85,85 \times 100$       d)  $48,045 \times 10$

Yuzlik	O'nlik	Birlik	,	O'ndan bir	Yuzdan bir	Mingdan bir



### Mustaqil ish: 20–22.

- 20.** Hisoblang.
- a)  $7,73 \times 0,45$       b)  $109,7 \times 18,7$       c)  $1,007 \times 22,33$       d)  $307,01 \times 5,1$   
 e)  $55,66 \times 8,7$       f)  $42,7 \times 7,06$       g)  $807,7 \times 5,17$       h)  $18,72 \times 10,07$
- 21.** 400 gektarga sholi ekildi. Agar bu butun ekin maydonining 0,25 qismini tashkil etsa, jami ekin maydoni qancha?
- 22.** Piyoda 4 km/h tezlik bilan 2,5 soat, 6 km/h tezlik bilan 1,5 soat yo'l yurdi. Jami bosib o'tilgan masofa qancha?

## O'NLI KASRNI NATURAL SONGA BO'LISH



## 1-usul

O'qli kasrdagi vergulga e'tibor berilmaydi va natural sonlarni bo'lish qoidasiga rioya qilinadi.

O'qli kasrning kasr qismidagi raqamlar nechta bo'lsa, natijaning chap tomonidan shuncha raqam ajratilib, vergul qo'yiladi.

$$\begin{array}{r} 9,6 \quad | \quad 2 \\ \underline{8} \quad | \quad 4,8 \\ 16 \\ \underline{16} \\ 0 \end{array}$$



## Guruhlarda ishlaymiz: 1-9.

1. Hisoblang.

- a)  $7,6 \div 2$                       b)  $4,8 \div 4$                       c)  $14,49 \div 7$                       d)  $12,8 \div 4$   
 e)  $6,3 \div 3$                       f)  $3,9 \div 3$                       g)  $17,9 \div 3$                       h)  $111,6 \div 9$

2. Baykal ko'li chuqurligi 1,61 km, Ladoga ko'lining chuqurligi esa undan 7 marta kam. Ladoga ko'lining chuqurligi qancha?

3. Hisoblang.

- a)  $16,4 \overline{)4}$                       b)  $4,52 \overline{)4}$                       c)  $35,5 \overline{)5}$                       d)  $9,75 \overline{)5}$



## 2-usul

O'qli kasr oddiy kasr ko'rinishiga keltiriladi, kasrlarni natural songa bo'lish qoidasiga rioya qilinadi.

$$62,72 \div 8 = \frac{6272}{100} \div 8 = \frac{6272 \div 8}{100} = \frac{784}{100} = 7,84$$

$$2,13 \div 3 = \frac{213}{100} \div 3 = \frac{213}{100} \times \frac{1}{3} = \frac{71}{100} = 0,71$$

4. Arqonning uzunligi 11,6 cm. Uni 4 ta teng bo'lakka bo'lish mumkinmi?

5. Hisoblang.

- a)  $1,4 \div 7$                       b)  $0,30 \div 5$                       c)  $0,66 \div 3$                       d)  $2,5 \div 2$   
 e)  $8,9 \div 5$                       f)  $1,8 \div 9$                       g)  $0,45 \div 9$                       h)  $0,21 \div 7$

6. Bir dona mevaning og'irligi qancha?

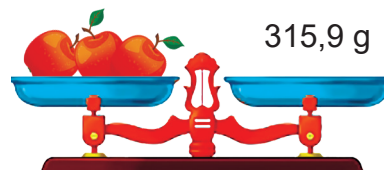
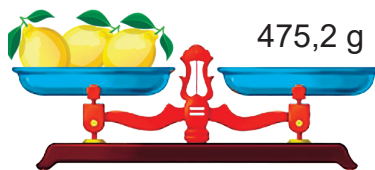
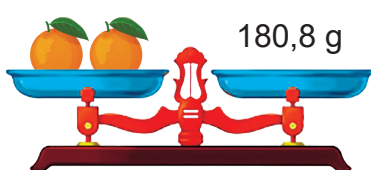

O'qli kasrning butun qismi bo'luvchidan kichik bo'lsa, bo'linmaning butun qismi 0 dan iborat bo'ladi.

$$\begin{array}{r} 0,646 \quad | \quad 38 \\ \underline{0} \quad | \quad 0, \\ 0 \end{array} \qquad \begin{array}{r} 0,646 \quad | \quad 38 \\ \underline{0} \quad | \quad 0,017 \\ 0,64 \\ \underline{38} \\ 266 \\ \underline{266} \\ 0 \end{array}$$

7. Jamilaning bo'yi 1,64 m. Singlisining bo'yi esa 2 marta past. Singlisining bo'yini metrda ifodalang.
8. Bo'lishni bajaring.
- a)  $3,6 \div 4$                       b)  $1,08 \div 6$                       c)  $3,15 \div 9$                       d)  $5,6 \div 8$   
 e)  $4,2 \div 7$                       f)  $1,16 \div 4$                       g)  $2,56 \div 8$                       h)  $2,52 \div 3$
9. Bo'lishni bajaring.
- a)  $6,48 \overline{)9}$                       b)  $3,84 \overline{)6}$                       c)  $4,41 \overline{)7}$                       d)  $2,08 \overline{)8}$



### Mustahkamlash: 10-14.

10. Bo'lishni bajaring.
- a)  $7,41 \div 3$                       b)  $5,26 \div 2$                       c)  $12,75 \div 3$                       d)  $35,44 \div 4$   
 e)  $55,38 \div 6$                       f)  $21,06 \div 6$                       g)  $21,36 \div 6$                       h)  $30,6 \div 6$
11. Orifjon 14,4 mln so'mlik mototsiklni 12 oyga teng bo'lib to'lash sharti bilan sotib oldi. Orifjon har oy qancha pul to'laydi?
12. Teng taqsimlang.

17,84  
kg

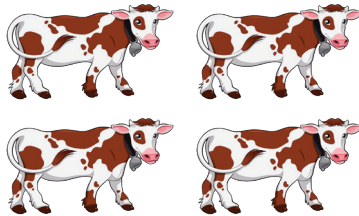
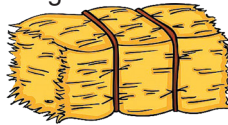

38,82  
kg

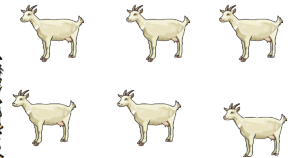
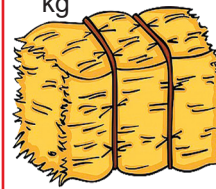

13. Hisoblang.
- a)  $6,30 \div 7$                       b)  $316,84 \div 8$                       c)  $1020,102 \div 51$                       d)  $24,66 \div 12$   
 e)  $0,007 \div 14$                       f)  $798,3 \div 36$                       g)  $1,21 \div 11$                       h)  $191,5 \div 5$
14. Bo'sh kataklarni to'ldiring.

$$9,78 \div 6 = \frac{\square}{100} \div \square = \frac{\square}{100} \div \frac{\square}{100} = \frac{\square}{100} = \square, \square$$

$$4,52 \div 4 = \frac{\square}{100} \div \square = \frac{\square}{100} \div \frac{\square}{100} = \frac{\square}{100} = \square, \square$$



### Mustaqil ish: 15-16.

15. Hisoblang.
- a)  $10,5 \div 5$                       b)  $0,002 \div 2$                       c)  $10,4 \div 13$   
 d)  $34,2 \div 100$                       e)  $549 \div 600$                       f)  $9 \div 1000$
16. Hisoblang.
- a)  $0,8 \div 200$                       b)  $1,6 \div 400$                       c)  $4,8 \div 600$   
 d)  $12 \div 6000$                       e)  $65 \div 5000$                       f)  $324 \div 1000$

## O'NLI KASRNI 10 GA, 100 GA, 1000 GA BO'LISH



## Eslaymiz!

Bo'lish  
qanday bajarilganini  
tushuntiramiz.

$$8,7 \div 10 = \frac{\square}{10} \div \frac{10}{1} = \frac{\square}{10} \times \frac{1}{\square} = \frac{87}{100} = 0,875$$

$$145,7 \div 100 = \frac{1457}{\square} \div \frac{100}{\square} = \frac{1457}{\square} \times \frac{1}{\square} = \frac{1457}{\square} = 1,457$$



O'ni kasrni 10, 100, 1000 ga bo'lish uchun:

$$8,45 \div 10 = 8,45$$

10 sonida 1 ta nol borligi uchun vergul chapga bir xona siljiriladi;

$$8,45 \div 100 = 0,0845$$

100 sonida 2 ta nol borligi uchun vergul chapga ikki xona siljiriladi;

$$8,45 \div 1000 = 0,00845$$

1000 sonida 3 ta nol borligi uchun vergul chapga uch xona siljiriladi.



## Guruhlarda ishlaymiz: 1-3.

1. Jadvalni to'ldiring.

÷	0,5	2,2	0,2	144	8,8	54,1	0,7	4,45	574,1
10	5								
100									
1000									

2. Hisoblang va xulosa qiling.

a)  $8 \div 10$

$0,8 \div 10$

$0,08 \div 10$

$0,008 \div 10$

b)  $2 \div 100$

$0,2 \div 100$

$0,02 \div 100$

$0,002 \div 100$

c)  $60 \div 1000$

$0,60 \div 1000$

$0,060 \div 1000$

$0,0060 \div 1000$

3. Hisoblang.

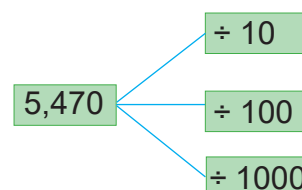
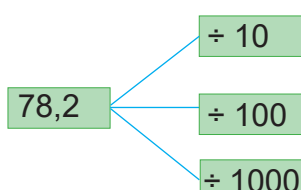
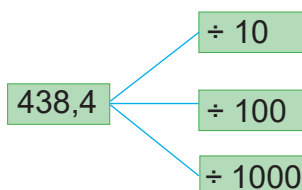



### Mustahkamlash: 4–8.

4. Hisoblang.

a)  $4,3 \div 1000$

b)  $0,9 \div 1000$

c)  $3,1 \div 10$

d)  $4,2 \div 10$

e)  $7,3 \div 10$

f)  $6,7 \div 10$

g)  $4,6 \div 100$

h)  $8,1 \div 10$

5. Bo'sh joylarni to'ldiring.

a)  $\underline{\quad} \div 100 = 4,58$

b)  $422 \div \underline{\quad} = 4,22$

c)  $637 \div \underline{\quad} = 6,37$

d)  $\underline{\quad} \div 100 = 6,26$

e)  $672 \div \underline{\quad} = 67,2$

f)  $898 \div \underline{\quad} = 89,8$

6. Modellar asosida hisoblang.

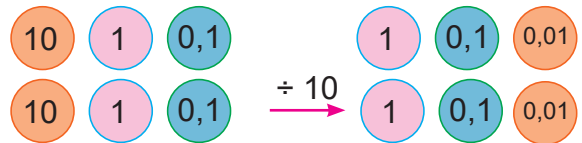
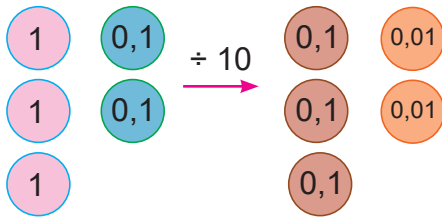

7. Bo'sh kataklarni to'ldiring.

0,5	÷		=	0,05
÷		÷		÷
	÷		=	
=		=		=
0,005	÷		=	0,005

25,5	÷		=	2,55
÷		÷		÷
10	÷		=	
=		=		=
	÷	10	=	0,255

8. Bo'luvchilar nimaga teng? Bo'linma-chi?

$2,8 \div \text{○} = 0,28$

$2,8 \div \text{○} = 0,028$

$2,8 \div \text{○} = 0,0028$

$4,08 \div \text{○} = 0,408$

$4,08 \div \text{○} = 0,00408$

$4,08 \div 1000 = \text{○}$



### Mustaqil ish: 9-11.

9. Hisoblang.

a)  $5,3 \div 1000$

b)  $0,09 \div 1000$

c)  $30,100 \div 10$

d)  $14,8 \div 10$

e)  $70,02 \div 100$

f)  $60,1 \div 10$

g)  $14,74 \div 100$

h)  $44,8 \div 100$

10.  $2010 \div 10 + 2010 \div 201 + 2010 \times 0$  ifodada bitta yoki ikkita qavsni shunday qo'yingki, uning qiymati eng kichik bo'lsin.

11. Bo'sh kataklarni to'ldiring.

a)  $25,25 \div 10 = \frac{\text{□}}{\text{□}} \div \frac{10}{1} = \frac{\text{□}}{100} \times \frac{1}{\text{□}} = \frac{\text{□}}{1000} = \text{□}, \text{□}$

b)  $0,07 \div 100 = \frac{7}{\text{□}} \div \frac{100}{\text{□}} = \frac{\text{□}}{\text{□}} \times \frac{1}{\text{□}} = \frac{7}{\text{□}} = \text{□}, \text{□}$

## O'NLI KASRLARNI BO'LISH



Bo'luvchining kasr qismidagi raqamlar nechta bo'lsa, berilgan bo'linuvchidagi vergul shuncha xona o'ngga suriladi.

O'nli kasrni natural songa bo'lish qoidasiga rioya qilinadi.

$$12,1,6 \div 3,2 = 3,8$$

$$12,16 \div 3,2 = \frac{1216}{100} \div \frac{32}{10} = \frac{1216}{100} \times \frac{10}{32} = \frac{38}{10} = 3,8$$

$$\begin{array}{r} 12,1,6 \overline{) 3,2} \\ \underline{96} \phantom{0} \\ 256 \\ \underline{256} \\ 0 \end{array}$$



## Guruhlarda ishlaymiz: 1-6.

1. O'nli kasrlarni bo'ling.

a)  $2,6 \div 6,5$

b)  $27,56 \div 5,2$

c)  $43,2 \div 4,5$

d)  $45,6 \div 8$

e)  $17,05 \div 5,5$

f)  $41,34 \div 5,3$

g)  $25,84 \div 3,4$

h)  $15,39 \div 1,9$

2. Hisoblang.

a)  $6,45 \overline{) 12,9}$

b)  $1,98 \overline{) 0,33}$

c)  $11,48 \overline{) 0,82}$

d)  $72,76 \overline{) 42,8}$

3. Ikki sonning ko'paytmasi 42,63 ga teng. Agar birinchi son 2,1 bo'lsa, ikkinchisini toping.



Agar bo'lish jarayonida qoldiqda 0 hosil bo'lmasa, bo'linuvchining o'ng tomoniga istalganicha 0 yozish mumkin.

$$\begin{array}{r} -16,30 \overline{) 5} \\ \underline{15} \phantom{0} \\ -13 \\ \underline{10} \\ -30 \\ \underline{30} \\ 0 \end{array}$$

4. Sonlarni bo'ling.

a)  $17 \div 2$

b)  $17 \div 4$

c)  $17 \div 8$

d)  $17 \div 10$

e)  $170 \div 2$

f)  $170 \div 4$

g)  $170 \div 8$

h)  $170 \div 10$

5. Bo'sh kataklarni to'ldiring.

a)  $2,52 \div 0,42 = \frac{252}{100} \div \frac{\square}{\square} = \frac{\square}{\square} \times \frac{\square}{\square} = \square$

b)  $6,72 \div 0,56 = \frac{\square}{100} \div \frac{\square}{100} = \frac{\square}{\square} \times \frac{\square}{\square} = \square$

c)  $8,65 \div 1,73 = \frac{\square}{\square} \div \frac{173}{100} = \frac{\square}{\square} \times \frac{\square}{\square} = \square$

d)  $20,85 \div 1,39 = \frac{\square}{\square} \div \frac{\square}{100} = \frac{\square}{\square} \times \frac{\square}{\square} = \square$

6. Bo'sh joylarni to'ldiring.

a)  $\square \div 2 = 0,5$

b)  $1,2 \div \square = 0,2$

c)  $0,3 \div \square = 0,1$

d)  $1,0 \div \square = 0,5$

e)  $\square \div 2 = 0,2$

f)  $1,64 \div \square = 0,41$



### Mustahkamlash: 7–10.

7. To'g'ri to'rtburchakning yuzasi  $300,9 \text{ m}^2$ , bo'yi  $20 \text{ m}$ . Uning perimetrini toping.

8. Hisoblang.

a)  $2,5 \div 0,5$

b)  $3,2 \div 4$

c)  $3 \div 0,15$

d)  $2,56 \div 1,6$

e)  $3,25 \div 2,5$

f)  $3,25 \div 0,5$

g)  $2,56 \div 0,64$

h)  $2 \div 0,025$

$2,15 \div 0,01 = 2,15 \times 100 = 215$



O'nli kasrni  $0,1$  ga,  $0,01$  ga,  $0,001$  ga bo'lish uchun shu sonni mos ravishda  $10$  ga,  $100$  ga,  $1000$  ga ko'paytirish kifoya.

9. Hisoblang.

a)  $258,12 \div 0,001$

b)  $259,26 \div 0,001$

c)  $25,23 \div 0,1$

d)  $2,9 \div 0,001$

e)  $155,15 \div 0,01$

f)  $256,23 \div 0,1$

g)  $0,025 \div 0,01$

h)  $16 \div 0,001$

i)  $0,27 \div 0,001$



O'nli kasrni  $0,1$  ga,  $0,01$  ga,  $0,001$  ga ko'paytirish uchun shu sonni mos ravishda  $10$  ga,  $100$  ga,  $1000$  ga bo'lish kifoya.

$1,52 \times 0,01 = 1,52 \div 100 = 0,0152$ .

10. Hisoblang.

a)  $2,24 \times 0,1$

b)  $1,84 \times 0,1$

c)  $365,4 \times 0,1$

d)  $181,3 \times 0,01$

e)  $97,6 \times 0,01$

f)  $86,1 \times 0,01$

g)  $12,23 \times 0,001$

h)  $7,56 \times 0,001$

i)  $756,01 \times 0,01$



### Qiziqarli matematika: 11–13.

11. Qog'ozning uzunligi  $20 \text{ cm}$ . Uning har bir uchida  $1,5 \text{ cm}$  qalinlikdagi yopishqoq qism mavjud. To'rtta tasmali qog'oz yopishtirildi hamda yopishqoq qismlar bir-birining ustiga to'liq tushganda qog'ozli halqa hosil bo'ldi. Halqaning uzunligi qancha?

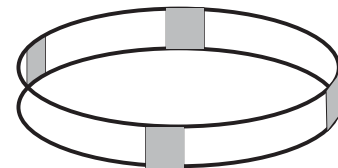
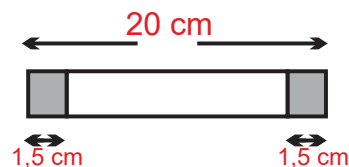

12. 16-blokdan 24-blokkacha masofa qancha? Har bir blok necha santimetr?

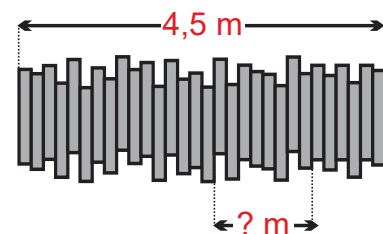

13. Javoblarni toping.

a) 10 sonini shunday ikki songa ajratingki, ularning ayirmasi 5 bo'lsin.

b) 23 sonidagi 2 bilan 3 soni orasiga qanday belgi qo'yilsa, 2 dan katta, lekin 3 dan kichik son hosil bo'ladi?

c) 1 ta tugma  $1,5$  gramm chiqsa, 1 milliontasi necha tonna bo'ladi?





### Mustahkamlash: 14–26.

14. Noma'lum sonni toping.

a)  $\square \times \frac{3}{10} = \frac{1}{12}$       b)  $\square \times \frac{5}{6} = \frac{7}{9}$       c)  $\square \times \frac{3}{5} = \frac{2}{15}$       d)  $\square \times \frac{5}{12} = \frac{3}{8}$

15. Bo'sh ustunni to'ldiring.

Oilalar	Oila a'zolari soni	1 oylik o'rtacha daromad (mln so'mda)	1 kishiga to'g'ri keladigan summa
Mahkamovlar oilasi	5	1,75	
Shomahmudovlar oilasi	3	1,25	

16. Masalalarni yeching.

- a) 5 ta ruchkaning narxi 14,50 ming so'm. 1 ta ruchkaning narxi qancha?  
 b) Bir qutining og'irligi 150,09 kg. 27 ta shunday qutining og'irligi qancha bo'ladi?  
 c) Idishda 13,5 L sharbat bor. Uni 3 ta bankaga teng quyildi. Har bir bankada qancha sharbat bo'ldi?

17. Sonlarning qaysi biri eng katta?

- a)  $10 \times 0,001 \times 100$       b)  $10000 \times 100 + 10$       c)  $0,1 \times 0,01 \times 10000$

18. Noma'lum tomonlarni toping. Umumiy shakl tomoni va yuzasi qancha?

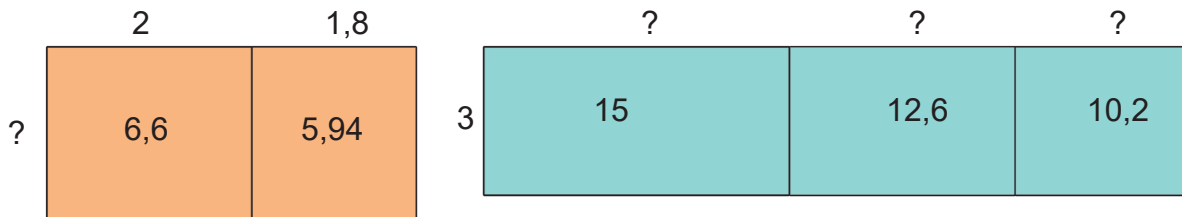

19. Hisoblang.



20. Bo'sh joylarni to'ldiring.

- a)  $1,8 \div \underline{\quad} = 0,2$       b)  $0,48 \div \underline{\quad} = 0,24$       c)  $\underline{\quad} \div 4 = 0,1$   
 d)  $\underline{\quad} \div 6 = 0,02$       e)  $0,3 \div \underline{\quad} = 0,1$       f)  $0,42 \div \underline{\quad} = 0,14$

21\*. Tenglamani yeching.

- a)  $8,32x - 4,25x + 3 = 19,28$       b)  $5,74x - 5,728x + 2 = 3,56$ ;  
 c)  $11,1x - 3,7x + 7,4 = 14,8$       d)  $62,5x + 0,5x - 21 = 42$ .  
 e)  $(x - 15,43) \times 0,4 = 3,73$       f)  $(2,86 - x) \div 2,2 = 0,76$

22. Vohid har kuni 3 minut davomida tishlarini tozalaydi. U tozalashning barcha qoidalariga amal qiladi. Afsuski, u bir safar suvni o'chirishni unutdi. Jo'mrakdagi suv oqimining tezligi 4,5 L/min bo'lsa, Vohid qancha suvni behuda ishlatdi? Hafta davomida shunday bo'lsa-chi?

23. Ifodalarning qiymatini toping.

a)  $(20 - 22,05 \div 2,1) - 6,4 + 9,2$

b)  $6,4 \times (13,3 - 12,8)$

c)  $50 - (22,95 \div 2,7 + 3,4) \times 2,8$

d)  $8,4 \times (18,4 - 17,9)$

24. Namuna asosida hisoblang:  $1,6 \div 20 = (1,6 \div 10) \div 2 = 0,16 \div 2 = 0,08$ .

a)  $4,8 \div 60$

b)  $0,51 \div 30$

c)  $3,44 \div 80$

d)  $1,6 \div 8000$

e)  $4,8 \div 300$

f)  $714 \div 7000$

25. Hisoblang: *Namuna:*  $2,9 \times 0,0001 = 2,9 \div 10000 = 0,00029$

a)  $2155,15 \times 0,001$

b)  $256,23 \times 0,1$

c)  $2,3 \times 0,001$

d)  $2,15 \times 0,01$

e)  $258,12 \times 0,001$

f)  $259,26 \times 0,0001$

26. Natijalarni taqqoslang.

Bo'lish	Ko'paytirish
$2 \div 0,2$	$2 \times \frac{5}{1}$
$3 \div 0,75$	$3 \times \frac{4}{3}$
$4 \div \frac{2}{3}$	$4 \times \frac{3}{2}$



### Mustaqil ish: 27-31

27. Noma'lumlarni toping.

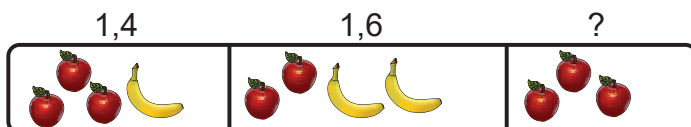
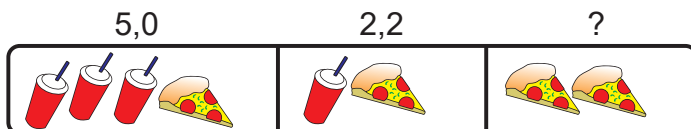

28. Ikki sonning ko'paytmasi 151,32 ga teng. Agar bittasi 7,8 bo'lsa, ikkinchisini toping.

29. Jamila 425,50 ming so'mga 9,25 metr mato sotib oldi. Bir metr matoning narxi qancha?

30. Bir kilogramm mahsulotning narxi 43,75 so'm. 17 kg mahsulot necha pul bo'ladi?

31. So'roq belgisi o'rniga qaysi amal belgisi qo'yilsa, tenglik to'g'ri bo'ladi?

a)  $8,8 ? 10 = 88$

b)  $44,55 ? 10 = 4,455$

c)  $0,36 ? 100 = 36$

d)  $7,5 ? 100 = 750$

e)  $10,5 ? 10 = 1,05$

f)  $3,78 ? 100 = 0,0378$

g)  $3,3 ? 100 = 0,033$

h)  $0,37 ? 10 = 3,7$

i)  $5,18 ? 100 = 0,0518$

## KASRNI O'NLI KASRGA KELITIRISH

## Eslaymiz!

Tengliklar to'g'rimi?

$$\frac{25}{100} = 0,25$$

$$\frac{8}{10} = 0,8$$

$$\frac{276}{1000} = 0,276$$

$$0,81 = \frac{81}{100}$$



Kasrni o'nli kasrga keltirish uchun kasrning asosiy xossasidan foydalanib maxraji 10 ning darajalaridan iborat bo'lgan teng kasr hosil qilinadi. Hosil bo'lgan o'nli kasr vergul bilan ajratib yoziladi.

$$\frac{1}{2} = \frac{1 \times 5}{2 \times 5} = \frac{5}{10} = 0,5$$

$$7\frac{1}{4} = 7\frac{1 \times 25}{4 \times 25} = 7\frac{25}{100} = 7,25$$



## Guruhlarda ishlaymiz: 1–5.

1. Namunadan foydalanib jadvalni to'ldiring.

a)	$\frac{13}{20}$	$\frac{65}{100}$	0,65
b)			0,3
c)			0,75
d)			0,2
e)			0,36

f)	0,75	$\frac{75}{100}$	$\frac{3}{4}$
g)	0,01		
h)	0,05		
i)	0,1		
j)	0,125		

2. Kasrlarni o'nli kasrga keltiring.

$$\frac{7}{25}$$

$$\frac{17}{50}$$

$$\frac{107}{125}$$

$$\frac{3}{12}$$

$$\frac{3}{250}$$

$$\frac{1}{40}$$

3. Bo'linmani kasr ko'rinishida yozing va o'nli kasrga keltiring.

a)  $5 \div 2$

b)  $11 \div 2$

c)  $9 \div 5$

d)  $13 \div 4$

4. Bo'sh kataklarni to'ldiring.

a)  $7 \div 2 = \frac{7}{2} = \frac{7 \times \square}{2 \times \square} = \frac{\square}{\square} = \square$

b)  $19 \div 20 = \frac{\square}{\square} = \frac{\square}{\square} \times \frac{\square}{\square} = \frac{\square}{\square} = \square$



Kasrni o'nli kasr ko'rinishiga keltirishda suratni maxrajga bo'lish usuli bilan ham amalga oshirish mumkin.

$$\begin{array}{r} 16 \quad | \quad 5 \\ - 15 \quad | \quad 3,2 \\ \hline - 10 \\ - 10 \\ \hline 0 \end{array}$$

$$\frac{16}{5} = 16 \div 5 = 3,2$$

5. O'nli kasr ko'rinishida yozing.

$$\frac{14}{8}$$

$$\frac{15}{12}$$

$$\frac{33}{50}$$

$$\frac{27}{25}$$

$$\frac{19}{20}$$

$$\frac{11}{8}$$



### Mustahkamlash: 6–13.

6. Halima xola 2,6 kg shakar sotib oldi. U 1,3 kg pishiriq tayyorlash uchun 325 g shakar ishlatgan. U jami shakardan necha kg pishiriq tayyorlay oladi?

7. Bo'yalgan sohaning yuzini toping va taqqoslang.

Qanday xulosaga keldingiz?

(Rasmda 2 ta katak 1 santimetr).

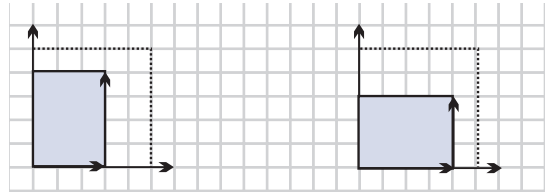

8. Jadvalni to'ldiring.

Kasr	$\frac{7}{2}$	$\frac{6}{5}$		$\frac{3}{25}$		$\frac{11}{20}$	$\frac{3}{8}$		
O'nli kasr			2,1		4,5			0,16	0,08

9. O'nli kasr ko'rinishida yozing.

a)  $\frac{3}{12}$

b)  $\frac{58}{100}$

c)  $8\frac{7}{40}$

d)  $17\frac{1}{125}$

e)  $10\frac{17}{25}$

10.  $\frac{7}{15}$  dan katta, lekin  $\frac{8}{15}$  dan kichik shunday kasr topingki, uning maxraji berilgan kasr maxrajidan kichik bo'lsin.

11. O'nli kasrlarni oddiy kasrga aylantiring.

a) 21,72

b) 54,972

c) 0,000893

d) 71,002

e) 811,56

12. Zohid haftada 4 kun 1,5 soatdan jang san'ati bilan shug'ullanadi. Bir hafta 7 kun ekanini hisobga olsak, uning haftada kunlik o'rtacha mashg'ulot vaqti qancha bo'ladi?

13. Abdurahmonning muzlatkichida 1,5 litr apelsin sharbati va 2,25 litr uzum sharbati bor. Abdurahimning muzlatkichida esa 1,15 litr apelsin sharbati va 0,62 litr uzum sharbati bor. Abdurahmonda Abdurahimga qaraganda qancha ko'p sharbat bor?



### Mustaqil ish: 14–15.

14. Mos o'nli kasrlarni toping.

Kasr	$\frac{3}{2}$	$\frac{99}{100}$	$\frac{2}{5}$	$\frac{9}{4}$	$\frac{49}{40}$	$\frac{3}{8}$	$\frac{3}{15}$	$\frac{18}{90}$
O'nli kasr								

15. 2022-yilda 4 dollar 3 yevroga teng edi. O'sha yili 6 yevro 324,36 hind rupiyasiga teng bo'ldi. O'shanda 1 dollarga necha hind rupiyasi olish mumkin bo'lgan?

## DAVRIY O'NLI KASRLAR



$$\begin{array}{r} 1 \overline{) 3} \\ \underline{0} \\ 10 \\ \underline{9} \\ 10 \\ \underline{9} \\ 10 \\ \underline{9} \\ 10 \\ \underline{9} \\ \dots \end{array}$$

$$\frac{1}{3} = 1 \div 3 = 0,333\dots$$

$$\begin{array}{r} 47 \overline{) 90} \\ \underline{0} \\ 470 \\ \underline{450} \\ 200 \\ \underline{180} \\ 200 \\ \underline{180} \\ 200 \\ \underline{180} \\ \dots \end{array}$$

$$\frac{47}{90} = 47 \div 90 = 0,5333\dots$$

0,333... → kasr qismida 3 takrorlanmoqda

0,5333... → kasr qismida 3 takrorlanmoqda

Davriy (takrorlanuvchi) o'nli kasrlar.

Qisqacha yozilishi:  $0,333\dots = 0,(3)$ ;  $0,5333\dots = 0,5(3)$

O'qilishi:  $0,(3)$  → 0 butun davrda 3

$0,5(3)$  → 0 butun o'ndan 5, davrda 3

$0,(3)$  → Davriy o'nli kasrning vergulidan keyin darhol takrorlanuvchi son boshlansa, **sof davriy o'nli kasr** deyiladi.

$0,5(3)$  → Davriy o'nli kasrdagi davr darhol emas, balki takrorlanmaydigan sonlardan keyin boshlansa, bunday o'nlik kasr **aralash davriy o'nli kasr** deyiladi.



## Guruhlarda ishlaymiz: 1-3.

1. Davriy o'nli kasrni qisqa ko'rinishda yozing.

a) 0,66666666666666...      b) 0,33333333333333...      c) 0,68181818181818...

2. Davriy o'nli kasr ko'rinishida ifodalang.

a)  $\frac{1}{3}$       b)  $\frac{2}{3}$       c)  $\frac{4}{9}$       d)  $\frac{7}{9}$       e)  $\frac{1}{6}$       f)  $\frac{5}{6}$

g)  $\frac{3}{11}$       h)  $\frac{8}{15}$       i)  $\frac{5}{22}$       j)  $\frac{1}{7}$       k)  $\frac{1}{30}$       l)  $\frac{6}{7}$

3. Oddiy kasrga mos davriy kasrlarni tutashtiring.

$$\frac{9}{33}$$

$$0,(148)$$

$$\frac{1}{30}$$

$$0,0(3)$$

$$\frac{5}{27}$$

$$0,(27)$$

$$\frac{6}{33}$$

$$0,(272)$$

$$\frac{8}{54}$$

$$0,(186)$$

$$\frac{15}{55}$$

$$0,(18)$$

## O'NLI KASR TURLARI

$$\frac{17}{25} = 17 \div 25 = 0,68$$

→ chekli o'nli kasr

$$\frac{2}{27} = 12 \div 18 = 0,074074074\dots$$

→ cheksiz davriy o'nli kasr

$$3,141592653\dots$$

→ cheksiz davriy bo'lmagan o'nli kasr



## Mustahkamlash: 4–7.

4. Davriy o'nli kasrni qisqa ko'rinishda yozing.

- a) 1,555...      b) 1,45454545...      c) 1,24444...      d) 2,0717171...  
 e) 1,3599999...      f) 3,8123123...      g) 0,0152152...      h) 0,123333...

5. Davriy o'nli kasrlarni cheksiz o'nli kasr ko'rinishida yozing.

- a) 0,(05)      b) 1,(17)      c) 0,(85)      d) 2,(14)  
 e) 1,4(3)      f) 3,(001)      g) 0,41(01)      h) 0,12(3)

6. Aralash sonlarni o'nli kasr ko'rinishida yozing.

$$1\frac{4}{33} \quad 1\frac{5}{9} \quad 2\frac{2}{11} \quad 2\frac{41}{333} \quad 3\frac{82}{666}$$

7. Noma'lum massani toping.

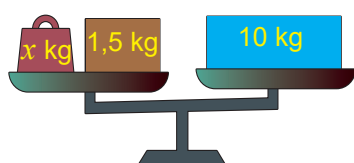

## Mustaqil ish: 8–10.

8. Davriy o'nli kasrni qisqa ko'rinishda yozing.

- a) 8,999...      b) 4,767676...      c) 2,14444...      d) 3,19171171...  
 e) 5,7544444...      f) 7,1123123...      g) 0,0142142...      h) 6,185555...

9. Davriy o'nli kasrlarni cheksiz o'nli kasr ko'rinishida yozing.

- a) 0,(06)      b) 2,(14)      c) 0,(45)      d) 1,(25)  
 e) 3,5(3)      f) 4,(007)      g) 0,35(04)      h) 0,18(2)

10. Davriy o'nli kasr ko'rinishida ifodalang.

- a)  $\frac{1}{2}$       b)  $\frac{3}{4}$       c)  $\frac{7}{9}$       d)  $\frac{2}{5}$       e)  $\frac{1}{3}$       f)  $\frac{6}{7}$   
 g)  $\frac{4}{11}$       h)  $\frac{9}{14}$       i)  $\frac{6}{24}$       j)  $\frac{1}{5}$       k)  $\frac{1}{40}$       l)  $\frac{2}{7}$

## O'NLI KASRLARNI YAXLITLASH



O'nli kasrni yaxlitlashda ma'lum qoidalarga rioya qilish kerak.

**Mingdan birlar xonasigacha yaxlitlash**

O'zgarmaydi 5 dan kichik

$$6,505 \overset{\downarrow}{\underset{\downarrow}{|}}{47} \approx 6,505$$

**Yuzdan birlar xonasigacha yaxlitlash**

O'zgaradi 5 ga teng

$$6,50 \overset{\downarrow}{\underset{\downarrow}{|}}{547} \approx 6,51$$

Yaxlitlamoqchi bo'lgan xonadan o'ngda 0, 1, 2, 3, 4 raqamlari bo'lsa, bu xonadagi raqam o'zgarmaydi.

Yaxlitlamoqchi bo'lgan xonadan o'ngda 5, 6, 7, 8, 9 raqamlari bo'lsa, bu xonadagi raqamga 1 soni qo'shiladi.

Eng yaqin butun songa yaxlitlash

5,636

5 raqami 6 ga o'zgaradi



$$5,636 \approx 6$$

6 raqami 5 dan katta bo'lgani uchun

O'ndan birlar xonasigacha yaxlitlash

5,636

6 raqami o'zgarmaydi



$$5,636 \approx 5,6$$

3 raqami 5 dan kichik bo'lgani uchun

Yuzdan birlar xonasigacha yaxlitlash

5,636

3 raqami 4 ga o'zgaradi



$$5,636 \approx 5,64$$

6 raqami 5 dan katta bo'lgani uchun



**Guruhlarda ishlaymiz: 1–3.**

1. O'nli kasrni o'ndan birlar xonasigacha yaxlitlang.

a) 87,52

b) 26,23

c) 95,01

d) 63,95

e) 96,873

f) 74,231

g) 745,96

h) 652,50

2. O'nli kasrni birlar xonasigacha yaxlitlang.

a) 6,9

b) 3,7

c) 5,2

d) 4,5

e) 7,1

f) 6,4

g) 28,6

h) 14,9

3. Quyidagi sonlarni yuzdan birlar xonasigacha yaxlitlang.

- a) 7,1417                      b) 4,5885                      c) 10,05175  
d) 19,9186                      e) 0,9975                      f) 89,706



### Mustahkamlash: 4–10.

4. Quyidagi o'nlik kasrni yuzdan birlar xonasigacha yaxlitlang.

- a) 2,999                      b) 17,891                      c) 9,786                      d) 4,567                      e) 99,999                      f) 25,398

5. Eng yaqin songa yaxlitlashda qaysi raqamlarni yaxlitlash mumkin?

- a) 35                                      b) 46                                      c) 72

6. Supermarketda 10 kg uzum 24,799 ming so'm turadi. Bu summa ikki do'st o'rtasida teng taqsimlanishi kerak. Shunda har biri qanchadan to'laydi?

7. Natijalarni butun songacha yaxlitlang.

- a)  $(0,008 + 0,992) \times (5 \times 0,6 - 1,4)$                       b)  $(0,93 + 0,07) \div (0,93 - 0,805)$   
c)  $(50\,000 - 1397,3) \div (20,4 + 33,603)$                       d)  $(2779,6 + 8027,4) \div (1,98 + 2,02)$

8. Yetishmayotgan raqamlarni toping.

- a)  $2,78 \underline{\quad} \approx 2,78$                       b)  $0,074 \underline{\quad} \approx 0,075$                       c)  $14,55 \underline{\quad} \approx 15$   
d)  $1,3 \underline{\quad} \approx 1,4$                       e)  $14,50 \underline{\quad} \approx 14,50$                       f)  $17,07 \underline{\quad} \approx 17,08$   
g)  $1,3456 \underline{\quad} \approx 1,34$                       h)  $10,001 \underline{\quad} \approx 10,001$                       i)  $76,544 \underline{\quad} \approx 76,545$

9. Berilgan sonni yaxlitlang.

- a) 8,525 ni eng yaqin butun songacha  
b) 8,525 ni eng yaqin o'ndan bir qismiga  
c) 8,525 ni yuzdan bir xonasigacha

10. To'g'ri javobni tanlang.

- a) 5,385 o'ndan birlar xonasigacha yaxlitlanganda 5,3; 5,4; 5,5 ga teng.  
b) 4,62 butun songa yaxlitlanganda 4,7; 4; 5 ga teng.  
c) 6,652 o'ndan birlar xonasigacha yaxlitlanganda 6,5; 6,6; 6,7 ga teng.  
d) 4,106 yuzdan birlar xonasigacha yaxlitlanganda 4,10; 4,11; 4,12 ga teng.



### Mustaqil ish: 11.

11. Bolalarning bo'yi va og'irligini o'ndan birlar xonasigacha, yoshini butun sonlarda yaxlitlang.

Ismi	Bo'yi (m)	Og'irligi (kg)	Yoshi
Adiba	1,076	34,57	11 yil-u 11 oy
Feruza	1,65	47,83	12 yil-u 8 oy
Ma'mura	1,43	39,55	13 yil-u 4 oy
Umida	0,97	27,07	9 yil-u 3 oy
Alimardon	1,07	32,65	10 yil-u 1 oy



## O'NLI KASRLAR USTIDA AMALLARGA DOIR TOPSHIRIQLAR

1. Surxondaryo viloyatidagi Hazrati Sulton, Markaziy Qizilqum (Navoiy viloyati)da joylashgan Muruntov, Jizzax viloyatida joylashgan Turalas tog'lari O'zbekistonning eng baland nuqtalaridan biridir. Tog'larni tartib bilan joylashtiring. Qaysi tog' eng baland, qaysi biri eng past.



Hazrat Sulton (4,688 km)



Muruntov (0,816 km)



Turalas (3,560 km)

2. Mirobod va Olmazor tumanlari orasidagi masofani toping.

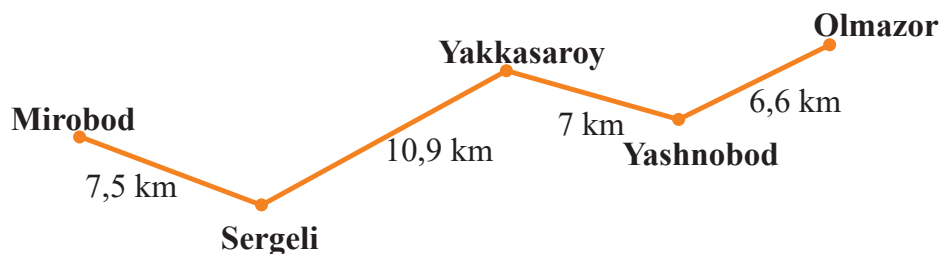

3. Harfiy ifodalarning qiymatini toping.

- a)  $0,13p + 0,47p$ ; agar  $p = 0,14$  bo'lsa      b)  $0,07b - 0,4b$ ; agar  $b = 5,4$  bo'lsa  
 c)  $3,8a + 1,7a - 5,4a$ ; agar  $a = 0,6$  bo'lsa      d)  $8,6c - 3,5c - 0,1c$ ; agar  $c = 0,58$  bo'lsa

4. Tenglamalarni yeching.

- a)  $9x + 6x - 0,15 = 6,15$       b)  $17x - x + 5x - 1,9 = 17$   
 c)  $1,7x + 88,42 = 94,2$       d)  $14,63x + 3,37x - 0,48 = 2,4$   
 e)  $16x - 7x + 0,96 = 2,22$       f)  $2,6x + 5,04 = 5,3$

5. Poyezd 2,8 soatda 135,8 km masofani bosib o'tdi. U shunday tezlikda 6,2 soat harakatlansa necha kilometr masofani bosib o'tadi?
6. Qizlar 1,8 kg pechenyega 45,36 ming so'm to'lashdi. 4,5 kg shunday pechenye uchun qancha pul kerak?
7. Jahongir maktabga avtobusda borib, piyoda qaytib kelsa, jami 3 soat yo'lda bo'ladi. Agar maktabga avtobusda borib kelsa, 1 soat vaqt sarflaydi. U maktabga piyoda borib, piyoda uyiga qaytsa, qancha vaqt sarflaydi?
8. Natijalarni yaxlitlang.
- a)  $0,372 + 3,649 + 4,8463$  yig'indi qiymatini yuzdan birlar xonasigacha  
 b)  $12,37267 - 8,674$  ayirma qiymatini mingdan birlar xonasigacha

9. Hisoblang.

a)  $13,5 \times 5,8 - 8,3 \times 4,2 - 5,8 \times 8,3 + 4,2 \times 13,5$

b)  $12,7 \times 64 + 173 \times 3,6 + 12,7 \times 36 + 17,3 \times 64$

10. CD masofa qancha?

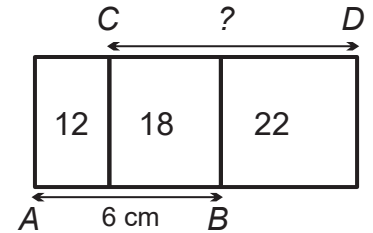

11. Tenglamalarni yeching.

a)  $(1,8 + x) - 21 = 71,4$

b)  $16(4x - 3,4) = 6,08$

c)  $(x - 1,25) - 4,5 = 27$

12. Ifodaning qiymatini toping.

a)  $1,6a + 1,6b$ , agar  $a + b = 100$  bo'lsa

b)  $2,5x - 2,5y$ , agar  $x - y = 4$  bo'lsa

13. Taqqoslang.

a) 1,36 kg va 589,6 g

b) 2396,4 kg va 2,278 kg

c) 28,4 mm va 2,84 cm

d) 92,6 cm va 9,24 dm

14. Oltinchi sinfda 100 nafar o'quvchi bor. Shundan 75 nafari nemis tilini, 85 nafari fransuz tilini, 10 nafari esa bu tillarning hech birini bilmaydi. Nechtadan o'quvchi faqat fransuz va faqat nemis tilini biladi?

15. Ali bilan Vali uylaridan chiqib, 0,2 soatdan so'ng uchrashdi. Agar ularning uylari orasidagi masofa 1,236 km va Vali 51 m/min tezlik bilan yurishi ma'lum bo'lsa, Alining tezligini toping?

16. Ikki velosipedchi bir nuqtani qarama-qarshi yo'nalishda tark etdi. Biri 12,4 km/h tezlikda, ikkinchisi 13,2 km/h tezlikda ketayotgan edi. Ular orasidagi masofa qancha vaqtdan keyin 133,12 km bo'ladi?

17. Piyoda va velosipedchi qishloqdan bir paytda yo'lga chiqdi va bir yo'nalishda piyoda 4,8 km/h, velosipedchi esa 12,4 km/h tezlikda harakatlandi. Qancha vaqtdan keyin ular orasidagi masofa 22,8 km ga teng bo'ladi?

18. Hisoblang.

a)  $84 \div 0,35 - 4,64 \div 5,8 - 60:48 + 2,9 \div 0,58$

b)  $40 - (2,0592 \div 0,072 - 19,63)$

c)  $7,67 \div 0,65 - (0,394 + 0,7688) \div 0,57$

19. Rasm asosida noma'lumni toping.

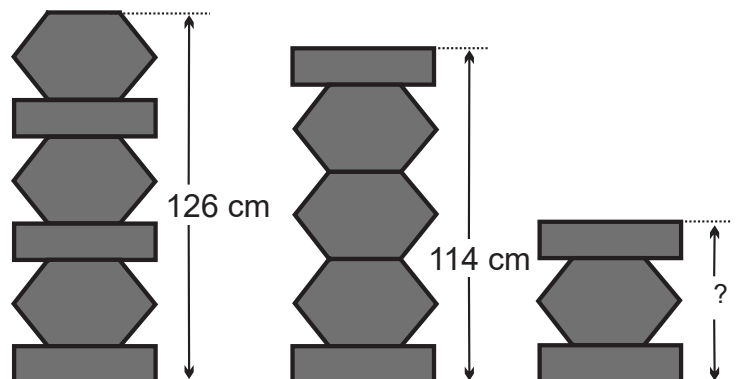

20. Tenglamani yeching.

a)  $9x + 3,9 = 31,8$

b)  $7x + 2,4 = 34,6$

c)  $(y + 4,5) \div 7 = 1,2$

d)  $(y - 1,8) \div 0,7 = 5,8$

21. Muhayyo kechki ovqatdan keyin jo'mrakni ochib 11 minut davomida idishlarni yuvadi. Suvning oqim tezligi 7,5 L/min.

Uzoq vaqtdan beri pulni tejash odat tusiga kirgan Umidaning oilasida esa idishlar kechki ovqatdan keyin hajmi 8,5 litrli rakovinada ikki marta suv bilan to'ldirilib yuviladi. Agar u suv hisoblagich o'rnatasa va bir kubometr suvning o'rtacha narxi 2000 so'm bo'lsa, bir oy ichida qancha pul tejaydi?

Muhayyo Umidaning odatini o'rganishi kerakmi?

22. Tahlilchilarning aytishiga qaraganda, 2020-yilda dunyo bo'ylab insonlar qo'lida 4 mlrd dona smartfon bo'lgan. Ayni damda Yer sayyorasi aholisi 7,6 mlrd ni tashkil qiladi. 1 kishiga to'g'ri keladigan smartfonlar soni nechta? Sonlarni o'ndan birlar xonasigacha yaxlitlang.

23. Agar savdogar molning 1 kilogrammini 16,5 so'mdan sotsa, 81,4 so'm zarar ko'radi. Agar 19,8 so'mdan sotsa, 162,8 so'm foyda ko'radi. Savdogarda necha kilogramm mol bor?

### Tarixiy ma'lumot

G'iyosiddin Jamshid al-Koshiy (taxminan 1430-yilda Samarqandda vafot etgan) – atoqli matematik va astronom. Asli Eronning Koshon shahridan bo'lib, boshlang'ich matematik ma'lumotni shu yerda olgan va XV asr boshida Mirzo Ulug'bekning taklifi bilan Samarqandga kelgan. Bu yerda Qozizoda Rumiy bilan birga Ulug'bek rasadxonasi va madrasasi qurilishiga rahbarlik qilgan. Koshiy astronomiyaga oid "Ziji Hoqoniy dar takmili ziji Elxoniy" ("Elxoniy astronomik jadvalini takomillashtirishda Hoqoniy astronomik jadvalining ahamiyati"), "Sullam us-samo" ("Osmon narvoni"), "No'zhat ul-xadoiq" ("Bog'lar sayri") va matematikaga oid "Risola al-muhitiyya" ("Aylana haqida risola"), "Risola ul-atvor nal-jayb" ("Vatarlar va sinus haqida risola"), "Miftoh ul-hisob" ("Arifmetika kaliti") asarlarini yozgan.



O'nli kasrlar va ular ustida amallar to'g'risida G'iyosiddin Koshiyning 1427-yilda yozilgan "Arifmetika" kaliti ("Miftoh ul-hisob") asarida birinchi marta bayon qilingan.

## Eratosfen g'alviri

Eratosfen g'alviri (Eratosfen elagi) —  $n$  natural songacha bo'lgan barcha tub sonlarni topish algoritmi bo'lib, qadimiy grek matematigi Eratosfen Kireniy sharafiga nomlangan. Eratosfen elagi algoritmi kichik (odatda 10 milliondan kichik bo'lgan) tub sonlarni topishning eng tez usuli hisoblanadi.

Avvalambor tub son nimaligini esimizga solib olaylik: faqat 1 ga va o'ziga bo'linadigan natural sonlar tub sonlar deyiladi.

Quyida  $n = 30$  uchun Eratosfen g'alvirini qo'llab tub sonlarni toping.

1. Buning uchun, 2 dan 30 gacha bo'lgan barcha butun sonlarni tartib bo'yicha yozib chiqamiz:

2. 2 dan 30 gacha bo'lgan sonlardan  $2^2 = 4$  dan boshlab 2 ga bo'linadiganlarni (2 dan tashqari, chunki 2 tub son) o'chirib chiqamiz.

3. Keyingi o'chirilmagan son 3. Ro'yxatdan  $3^2 = 9$  dan boshlab 3 ga bo'linadiganlarini (3 dan tashqari, chunki 3 tub son) o'chirib chiqamiz.

4. Ro'yxatdan endi  $5^2 = 25$  dan boshlab 5 ga bo'linadiganlarini (5 dan tashqari, chunki 5 tub son) o'chirib chiqamiz.

5. Jarayonni shu yerda to'xtatamiz. Chunki  $7^2 > 30$ .

	②	③	4	⑤	6	7	8	9	10
11	12	13	14	15	16	17	18	19	20
21	22	23	24	25	26	27	28	29	30

Demak bo'yalmay qolgan sonlar: 2; 3; 5; 7; 11; 13; 17; 19; 23; 29.

## Topshiriq.

1. 1000 gacha bo'lgan sonlarni Eratosfen g'alviridan o'tkazing. Qaysi sonlar g'alviridan o'tmaydi?

## Tarixiy ma'lumot

ERATOSFEN (mil.av. taxm. 276, Kirena, hozirgi Liviya – 194, Aleksandriya, Misr) – qadimiy yunon olimi. Aleksandriya (Iskandariya) va Afina shaharlarida tahsil olgan. Iskandariya kutubxonasining boshlig'i bo'lgan. Matematika fanida tub sonlarni topish usulini taklif etgan. Matematik geografiyaga asos solgan, jumladan, yer yuzining obod qismi (oykumena) ning xaritasini tuzgan. Birinchi bo'lib yer meridiani yoyi uzunligini hisoblagan. Fanga "geografiya", "kenglik", "uzunlik" tushunchalarini kiritgan. Eratosfen xronologiya, astronomiya, tilshunoslik, falsafa va musiqa bilan ham shug'ullangan. Eratosfen asarlarining ayrim qismlarigina bizgacha yetib kelgan.

# IV bob

## BUTUN SONLAR

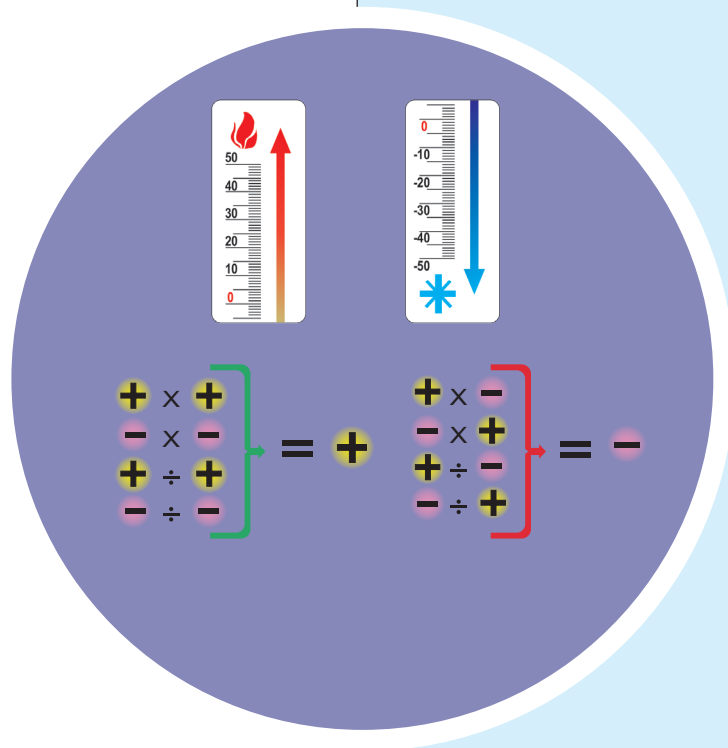

## MUSBAT VA MANFIY SONLAR. BUTUN SONLAR HAQIDA TUSHUNCHA



Eslaymiz!



Sonlar qatorini o'qiymiz. Ular qanday sonlar?

1; 2; 3; 4; 5; 6; 7; 8; 9; 10; 11; 12; 13; ...

0 soni-chi?

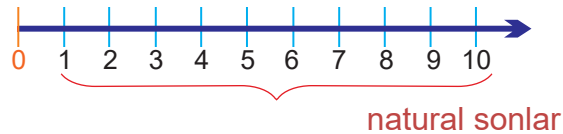

Kundalik hayotda yana qanday sonlarni uchratamiz?



Ob-havo



+4° -4°

+4°C → 4 daraja issiqni, -4°C → 4 daraja sovuqni bildiradi.

Sonlar oldida "+" ishorasi bo'lsa, ular **musbat sonlar** deyiladi. Odatda bu sonlar oldidagi "+" ishorasi yozuvda tushib qoladi. Demak, 1; 2; 3; 4; 5; 6; 7; 8; 9; 10; 11; 12; 13; ... → **musbat sonlar**.

Sonlar oldida "-" ishorasi bo'lsa, ular **manfiy sonlar** deyiladi.

-1; -2; -3; -4; -5; -6; -7; -8; -9; -10; -11; -12; -13; ... → **manfiy sonlar**.

Bir-biridan faqat ishorasi bilan farq qiladigan sonlar **qarama-qarshi sonlar** hisoblanadi.

**0 → musbat ham, manfiy ham emas.**

Natural sonlar, ularga qarama-qarshi bo'lgan sonlar va nol **butun sonlar** deyiladi.

{ ..., -7; -6; -5; -4; -3; -2; -1; 0; 1; 2; 3; 4; 5; 6; 7; ... }

0; 7; 212 va -1023 → butun sonlar.  $\frac{1}{2}$ ; 1,1 va -5,2 → butun sonlar emas.



Guruhlarda ishlaymiz: 1-2.

1. Berilgan sonlar bilan jadvalni to'ldiring.

-8; -2; 0; 2; 8; -7; -1; -0,(2); -2,2(1);  
 0,5; 12; -15; -9; 11; 21; -10;  $\frac{1}{4}$ ;  $-\frac{7}{9}$ ;  
 -3; 0; 9; 14; -6; -4; 0,7.

Butun sonlar	
Musbat butun sonlar	
Manfiy butun sonlar	

2. Rasmdagi termometrlar yordamida haroratning o'zgarishini tushuntiring.

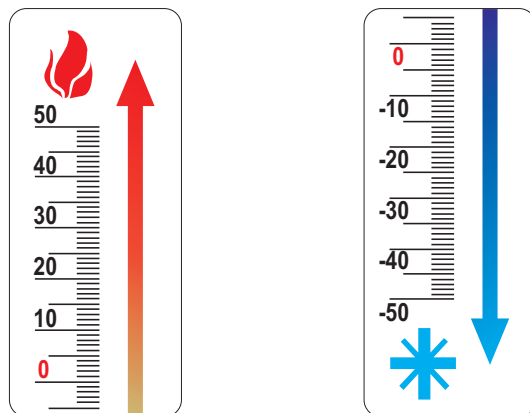



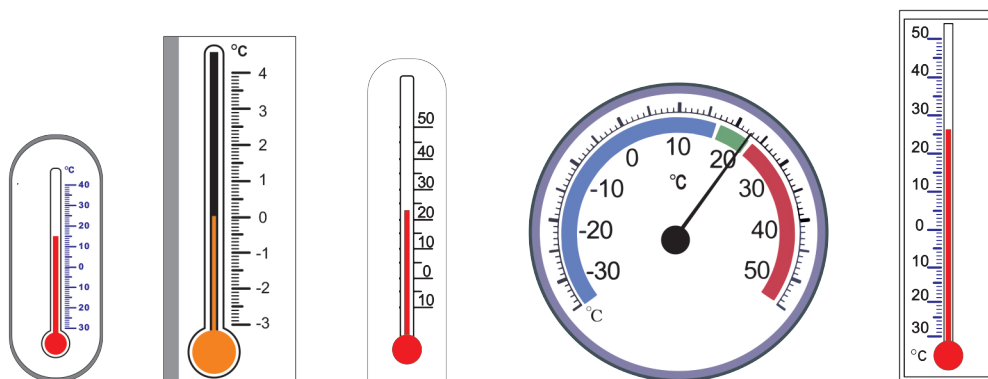

### Mustahkamlash: 3–9.

3. Termometrlardagi ob-havo harorati ko'rsatkichini aniqlang.



4. Bank plastik kartasiga tushgan pul miqdori musbat sonlarda, plastik hisob raqamidan olingan pul mablag'lari esa manfiy sonlarda ifodalanadi. Quyidagi jadval asosida monitoringni o'qing.

	MA'MURAXON YUSUPOVA	⌚ 09:37 31.10.2021 -23 000.00 UZS
	OCHILOVA ZAMIRA	⌚ 14:27 28.10.2021 +30 000.00 UZS
	MOHIRJONOV USMONJON	⌚ 12:25 10.10.2021 +15 000.00 UZS
	Davlat Test Markazi (DTM)	⌚ 14:55 20.07.2021 -124 195.75 UZS
	Ucell	⌚ 08:02 20.07.2021 -4 000.00 UZS
	Gaz. Toshkent shahri	⌚ 15:24 19.07.2021 -50 000.00 UZS
	Sovuq suv va kanalizatsiya	⌚ 15:23 19.07.2021 -50 000.00 UZS
	Elektroenergiya	⌚ 15:22 19.07.2021 -29 000.00 UZS

5. Kunduzgi va kechki ob-havoni tahlil qiling.



6. Tavsiflarga mos keladigan butun sonlarni yozing.
- Elektr energiyasidan haqdorlik 40 ming so'm, gazdan qarzdorlik esa 225 ming so'm.
  - Hazrati Sulton cho'qqisi dengiz sathidan 4648 m balandlikda, Chirchiq daryosi sohili dengiz sathidan 380 m pastda.
  - Haroratning  $40^{\circ}\text{C}$  ga isishi,  $10^{\circ}\text{C}$  ga sovishi.
  - Kit okean sathidan 100 metr pastda.
  - Aysberg dengiz sathidan 125 metr balandlikda joylashgan.

7. Jadvalda shaharlardagi 2022-yil 1-yanvarga oid harorat ko'rsatilgan.

Shaharlar	Harorat
Qohira	$15^{\circ}\text{C}$
Kopengagen	$1^{\circ}\text{C}$
Helsinki	$-9^{\circ}\text{C}$
Liverpul	$3^{\circ}\text{C}$
Moskva	$-14^{\circ}\text{C}$
Sidney	$20^{\circ}\text{C}$

- Eng past harorat ko'rsatilgan shahar qaysi?
  - Kopengagen va Qohiradagi harorat qanchaga farq qiladi?
  - 2003-yil 2-yanvarda Moskvada havo harorati  $4^{\circ}\text{C}$  ga ko'tarilgan. Moskvadagi yangi haroratni hisoblang.
8. Smartfonning ob-havo ilovasida harorat Londonda  $-7^{\circ}\text{C}$ , O'zbekistonda esa  $+2^{\circ}\text{C}$  ni ko'rsatdi. Londondagi harorat O'zbekistondagidan necha gradus farq qilmoqda?

9. Quyidagi savollarga javob bering.
- Qanday sonlar "musbat sonlar" deyiladi? Musbat butun sonlar-chi?
  - Qanday sonlar "manfiy sonlar" deyiladi? Manfiy butun sonlar-chi?
  - Qanday sonlar musbat ham, manfiy ham emas?
  - Barcha natural sonlarni butun sonlar deyish mumkinmi? Musbat natural son deyish-chi?
  - Do'stingiz: "Kasrlar butun sonlardir", – deb aytdi. Uning fikriga qo'shilasizmi?



### Mustaqil ish: 10–12.

10. Sotuvchi Salima xola bir xil miqdordagi 4 xil mahsulot sotib olib, keyinchalik ularni sotdi. Jadval asosida foyda yoki zararni aniqlang.

	Sotib olish narxi (so'm)	Sotish narxi (so'm)	Foyda (so'm)	Zarar (so'm)	Savdo natijasi (so'm)
1	95 500	100 000			
2	124 000	123 000			
3	142 000	156 000			
4	173 000	171 500			
Jami					

11. Ob-havo harorati ko'rsatkichini "+" va "-" ishoralaridan foydalanib yozing.

- $36^{\circ}\text{C}$  issiq
- $17^{\circ}\text{C}$  issiq
- $7^{\circ}\text{C}$  sovuq
- $18^{\circ}\text{C}$  sovuq
- $1^{\circ}\text{C}$  sovuq
- $1^{\circ}\text{C}$  iliq

12. Termometr yordamida ob-havo haroratini hafta davomida kuzating va yozib boring. Xulosa tayyorlang.



## MUSBAT VA MANFIY BUTUN SONLARNI SON O'QIDA TASVIRLASH



Musbat va manfiy butun sonlar son o'qida quyidagicha tasvirlanadi:

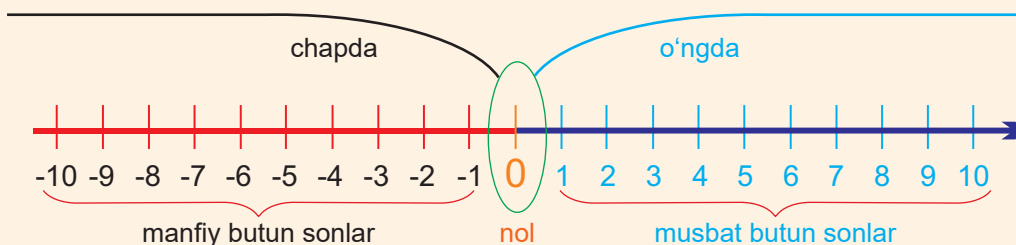

2 soni A nuqtaning koordinatasi:  $A(2)$

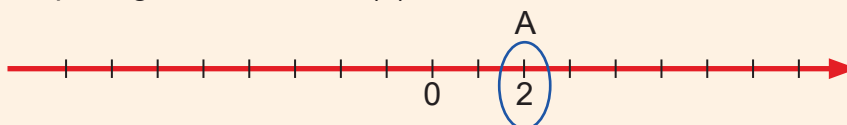

-6 soni B nuqtaning koordinatasi:  $B(-6)$

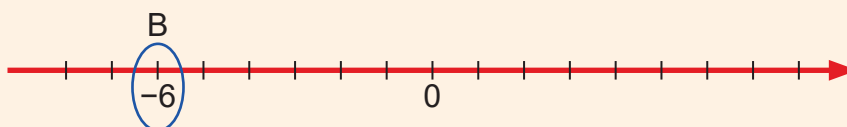

### Guruhlarda ishlaymiz: 1-5.

1. Sonlarning 0 soniga nisbatan joylashuvini aniqlang.

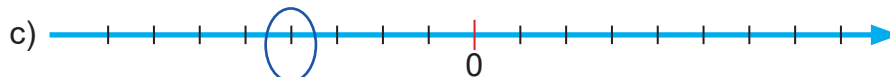

2. Sonlar o'qida belgilang.



3. Sonlar o'qida harflarga mos keladigan sonlarni toping.



4.  $A(0)$ ,  $B(4)$ ,  $C(-2)$ ,  $D(-7)$ ,  $K(-3)$ ,  $M(6)$  nuqtalarni sonlar o'qida belgilang.

5. Tushirib qoldirilgan sonlarni toping.

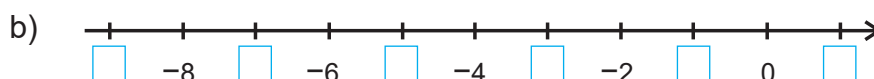



### Mustahkamlash: 6–10.

6. Bo'sh kataklar o'rnidagi sonlarni toping.

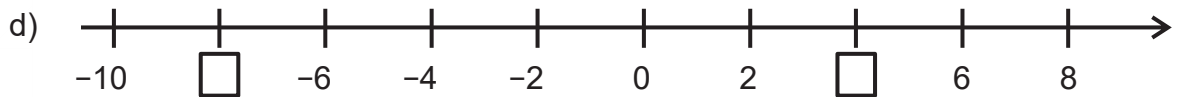
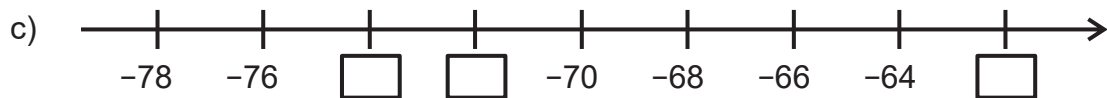
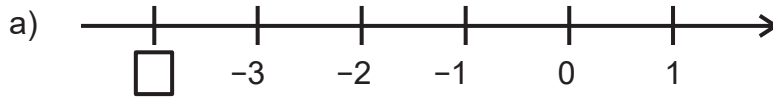

7. Sonlar o'qini chizing va  $-7$  nuqtadan  $+7$  nuqttagacha nechta butun son,  $-7$  nuqtadan  $+7$  nuqttagacha nechta natural son borligini toping.

8. Jadvalni o'qing va tushuntiring.

Jo'natuvchi	Oluvchi	Amaliyot sanasi	Summa
860031*****4672	860033*****7225	22.12.2021 21:43	-8 712 000.00
860031*****4672	860004*****4672	22.12.2021 15:25	10 900 000.00
860049*****4756	986035*****5723	21.12.2021 13:44	100 000.00
860031*****4672	986035*****5723	19.12.2021 17:02	-98 000.00
860031*****4672	986035*****5723	16.12.2021 11:17	-500 000.00
986035*****5723	860049*****4756	15.12.2021 21:49	-100 000.00
860031*****4672	986035*****5723	15.12.2021 17:52	-167 000.00
986035*****5723	860031*****4672	15.12.2021 14:33	101 000.00

9. Birlik kesmani 10 ga teng deb olib, sonlar o'qida berilgan sonlarni belgilang.

-20      0      10      15      -25      -35      -5      5

10. So'roq belgisi o'rnidagi sonlarni toping.

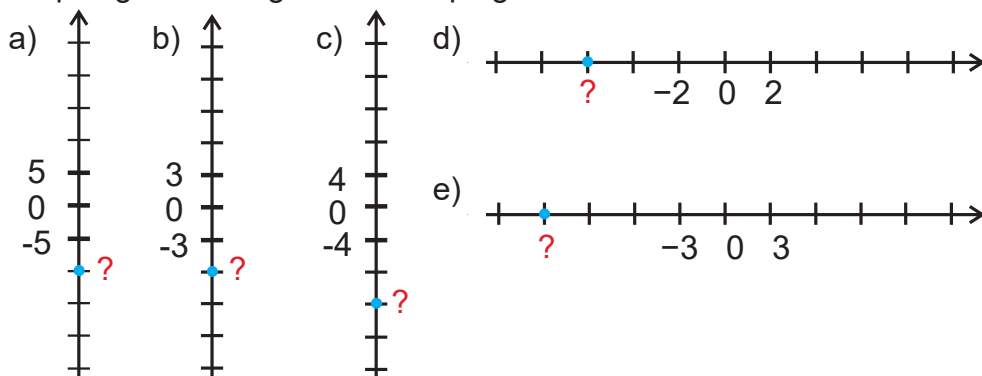



### Mustaqil ish: 11–12.

11. Nuqtalarning koordinatalarini yozing.

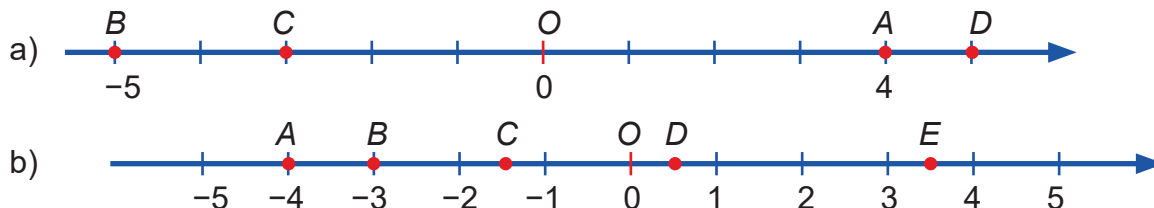

12. Jadvaldan foydalanib son o'qida nuqtalarni belgilang.

Nuqta	A	B	C	D	E	F	P	Q
Koordinatasi	2	-3	4	-2	1	3	-5	5

## SONNING MODULI



### Eslaymiz!

$-3$  va  $3$ ;  $4,6$  va  $-4,6$ ;  $\frac{3}{4}$  va  $-\frac{3}{4}$  Sonlar nimasi bilan farq qiladi?



**Sonning moduli** uning son o'qida 0 sonidan qancha uzoqligini bildiradi.

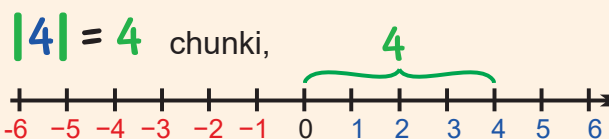

U  $|a|$  kabi belgilanadi va

“a sonning moduli” deb o'qiladi.

Sonning moduli **sonning absolyut qiymati** ham deyiladi.

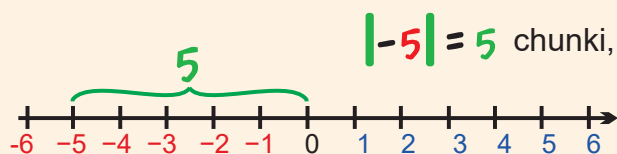

### Guruhlarda ishlaymiz: 1–5.

1. So'roq belgisi o'rnidagi sonlarni modulda ifodalang.

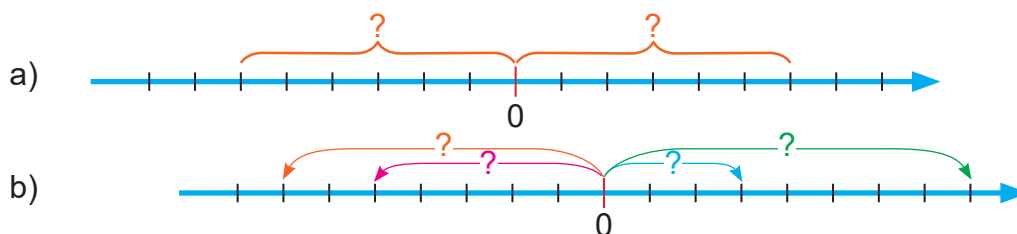

2. Modulli sonlarni dastlab o'qing, keyin modulini toping.

- a)  $|-23|$       b)  $-|-23|$       c)  $|23|$       d)  $-|23|$   
 e)  $|-|-23||$       f)  $|-|23||$       g)  $||-23||$       h)  $||23||$

Qarama-qarshi sonlarning modullari o'zaro teng bo'ladi:

$$|4| = |-4| = 4$$

$$|a| = |-a|$$

0 sonining moduli 0 ga teng:

$$|0| = 0$$

3. Sonlarning modulini toping.

-15	-222	0	107	108	-61	-190
0,8	122	-45	-97	1111	20	-457
-47	119	901	256	-603	-4,7	0,05

4. Son o'qida belgilangan sonlarga modullari teng sonlarni toping.

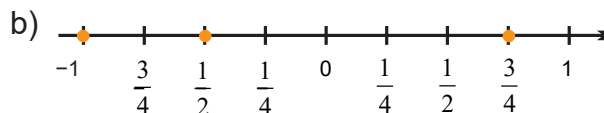
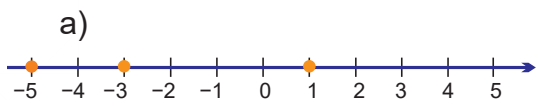

Modulli sonlar ustida arifmetik amallarni bajarish tartibi quyidagicha:

$$|-45| + |25| = 45 + 25 = 70$$

$$|-9| \times |15| = 9 \times 15 = 135$$

$$|3,8| - |-1,7| = 3,8 - 1,7 = 2,1$$

$$|306| \div |-3| = 306 \div 3 = 102$$



5. Hisoblang.

a)  $|-37| + |-25|$

b)  $|519| + |-150|$

c)  $|-123| + |453| - |-4| \times |-5|$

d)  $|-99| + |-77|$

e)  $|-20| \times |90|$

f)  $|1800| \div |-30|$



Mustahkamlash: 6-10.

6. Sonlar o'qini chizamiz va O(0) nuqtadan quyidagi nuqtalargacha bo'lgan masofani toping.

A(-4)

B(4)

C(-4,5)

D(5,5)

E(-2)

F(-1/2)

7. So'roq belgisiga mos keluvchi modullarni toping.

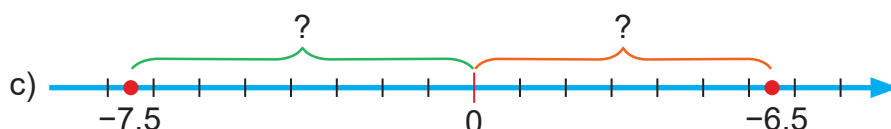
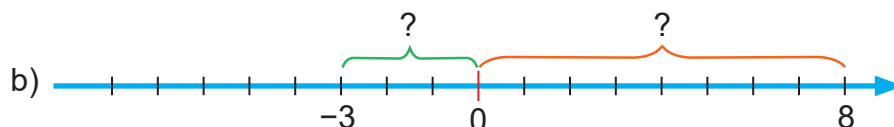
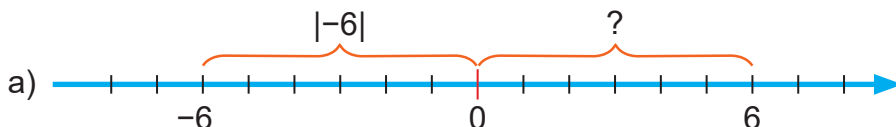

8. Modullari teng sonlarni tutashtiring.

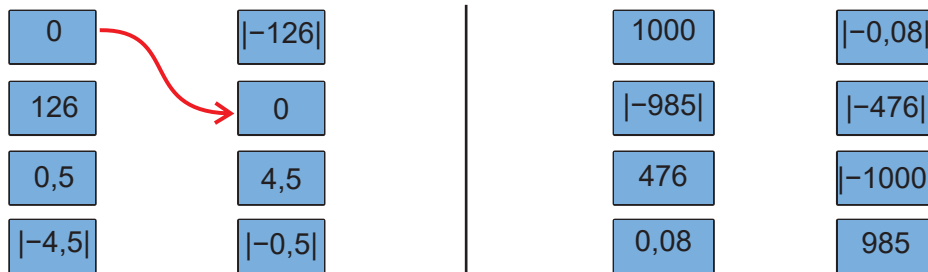

9. Hisoblang.

a)  $|240| \div |-80|$

b)  $|-710| + |-290|$

c)  $|2,3| + |-3,7|$

d)  $|0,1| \times |-10|$

e)  $|\frac{4}{5}| - |\frac{2}{3}|$

f)  $|-2\frac{1}{3}| \times |\frac{9}{14}|$

g)  $|-8\frac{1}{3}| \div |\frac{5}{9}|$

h)  $|\frac{3}{8}| + |\frac{4}{5}|$

10. Moskvada qishki harorat  $-10\text{ }^{\circ}\text{C}$ , yozgi harorat  $+23\text{ }^{\circ}\text{C}$  bo'ladi. Bu haroratlarning qaysi biri suvning muzlash darajasiga yaqinroq?



### Qiziqarli matematika: 11

11. Maryam g'ishtlarga musbat butun sonlarni yozmoqda. Agar har bir g'ishtdagi son uning pastki qismida turgan 2 ta g'ishtdagi sonlar yig'indisiga teng bo'lsa, Maryam eng ko'pi bilan nechta toq son yoza oladi?

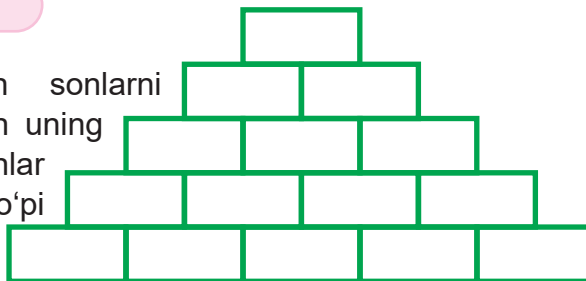

### Mustaqil ish: 12-13.

12. Jadvalni to'ldiring.

$a$	-4		-7		-6		28		67	
$-a$		0,8		-24		-13		-180		19
$ a $										

13.  $5|b| + |a| - |-6|$  ifodaning qiymatini hisoblang.

a)  $a = 17$  va  $b = 21$

b)  $a = -45$  va  $b = 27$

c)  $a = -21$  va  $b = -17$

14. Berilgan sonlarga qarama-qarshi sonni toping.

-12

-122

0

17

18

-71

-19

-37

117

91

146

-63

-4,7

0,008

15. Har bir vaziyatning aksini ifodalovchi sonni yozing. So'z bilan qarama-qarshi ma'noni yozing.

a) 25 000 so'm haqdor

b) dengiz sathidan 3 500 metr pastda

c)  $21\text{ }^{\circ}\text{C}$  issiq

d) 13 kilogramm vazn yo'qotish

## BUTUN SONLARNI TAQQOSLASH



## Eslaymiz!

$$\dots > 10 > 9 > 8 > 7 > 6 > 5 > 4 > 3 > 2 > 1 > 0$$

$$0 < 1 < 2 < 3 < 4 < 5 < 6 < 7 < 8 < 9 < 10 < \dots$$

Har bir son o'zidan oldingi sonlardan katta, o'zidan keyingi sonlardan kichik.

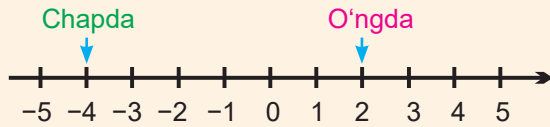

$$-4 < 2$$

Butun sonlarni taqqoslashda o'ngdagi son chapdagi sondan katta bo'ladi. Yoki aksincha, chapdagi son o'ngdagi sondan kichik bo'ladi.

Har qanday musbat son ixtiyoriy manfiy sondan katta.  
0 soni ixtiyoriy manfiy sondan katta, musbat sondan esa kichik.



## Guruhlarda ishlaymiz: 1-3.

1. Son o'qi yordamida taqqoslang.

- a) -8 va 1                      b) -6 va 6                      c) 6 va 8                      d) -10 va -6

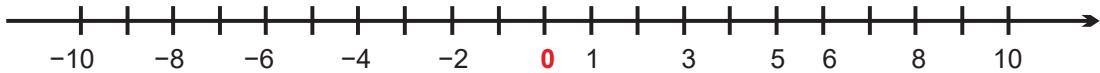

2. Taqqoslang.

- a) 2 va 87      b) 10 va -10      c) -22 va -102      d) 3 va -1      e) -4 va 2  
f) -4 va 8      g) -2 va -8      h) -15 va -7      i) -7 va 1      j) 2 va -3

3. Meteorolog dunyoning to'rtta shahridagi haroratni qayd etdi. Bu shaharlarni harorat bo'yicha o'sish tartibida ayting.

Eng issiq va eng sovuq shaharlarni belgilang.

Shaharlar	Harorat
London	+5 °C
Anqara	-6 °C
Moskva	-7 °C
Berlin	-9 °C
Toshkent	+12 °C



## Mustahkamlash: 4-9.

4. Son o'qidagi sonlarni o'sish va kamayish tartibida yozing.

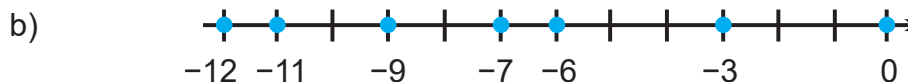

5. Savollarga javob bering.

- a) Qaysi ifodada 85 va 19 sonlari to'g'ri taqqoslangan?  
A)  $85 < 19$                       B)  $19 = 85$                       C)  $85 > 19$                       D)  $19 > 85$
- b) Qaysi son katta, 71 yoki 710?  
A) 71                      B) 710

c) Qaysi son kichik,  $-17$  yoki  $-11$ ?

A)  $-17$

B)  $-11$

d) Dehqon bu yil 2350 ta qovoq yetishtirdi. O'tgan yili u 1988 ta qovoq yetishtirgan edi. Shu ikki miqdorni taqqoslovchi ifodani yozing.

A)  $2350 > 1988$

B)  $2350 < 1988$

C)  $1988 = 2350$

D)  $1988 > 2350$

6. Son o'qida belgilangan sonlarni taqqoslang.

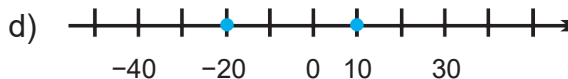
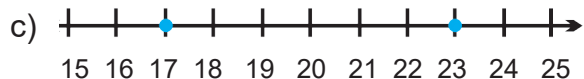
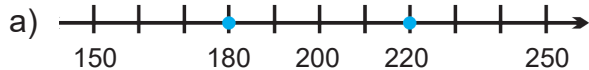

7. Berilgan sonlarni taqqoslang va " $>$ ", " $<$ " yoki " $=$ " belgilaridan mosini qo'ying.

a)  $+7 \dots +17$

b)  $+53 \dots -53$

c)  $0 \dots -25$

d)  $-108 \dots -108$

e)  $-12 \dots +14$

f)  $-26 \dots 0$

g)  $+5 \dots -60$

h)  $-10 \dots 0$

8. Har bir juft termometrni taqqoslang.

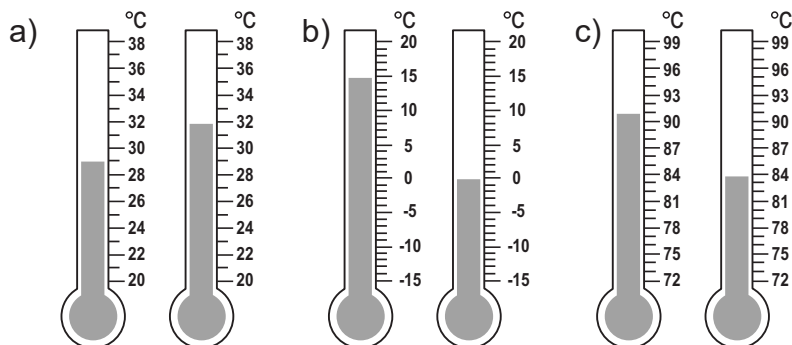

9. Berilgan butun sonlardan oldin va keyin keladigan butun sonlarni yozing.

a) \_\_\_\_\_  $-7$  \_\_\_\_\_

b) \_\_\_\_\_  $-1000$  \_\_\_\_\_

c) \_\_\_\_\_  $24$  \_\_\_\_\_

d) \_\_\_\_\_  $-665$  \_\_\_\_\_

e) \_\_\_\_\_  $-39$  \_\_\_\_\_

f) \_\_\_\_\_  $0$  \_\_\_\_\_



**Mustaqil ish: 10–11.**

10. Sonlar nurida taqqoslang.



a) A va B

b) B va P

c) D va F

d) C va Q

e) E va F

11. Bo'sh kataklarni to'ldiring.

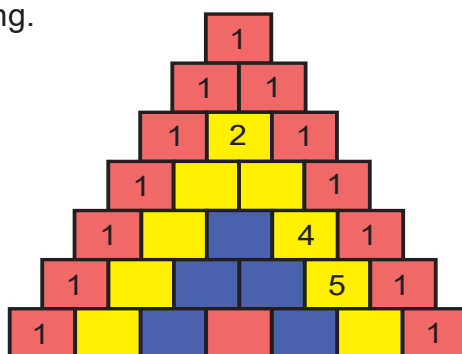



$$+2 + (+4) = +6$$

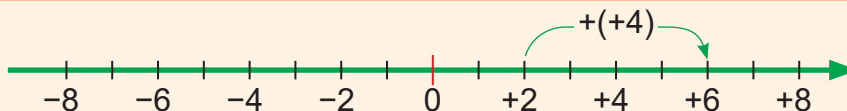

$$-2 + (-4) = -6$$



Bir xil ishorali butun sonlarni qo'shish uchun ikkinchi qo'shiluvchi musbat bo'lsa, o'ng tomonga, manfiy bo'lsa, chap tomonga shuncha birlik siljitamiz.



### Guruhlarda ishlaymiz: 1-6.

1. Sonlar o'qidan foydalanib musbat butun sonlarni qo'shing.

a)  $(+7) + (+5)$

b)  $0 + (+9)$

c)  $(+6) + (+3)$

d)  $(+1) + 0$

e)  $(+5) + (+8)$

f)  $(+5) + (+3)$

g)  $(+8) + 0$

h)  $(+3) + (+8)$

2. Sonlar o'qidan foydalanib manfiy butun sonlarni qo'shing.

a)  $(-3) + (-7)$

b)  $(-2) + (-6)$

c)  $(-8) + (-4)$

d)  $0 + (-1)$

e)  $(-1) + 0$

f)  $(-5) + (-3)$

g)  $(-8) + (-1)$

h)  $(-4) + (-9)$

3. Butun sonlar yordamida savollarga javob toping.

a) Harorat  $+4\text{ }^{\circ}\text{C}$  dan  $15\text{ }^{\circ}\text{C}$  ga ko'tarildi. Endi harorat qancha bo'ldi?

b) Harorat  $-3\text{ }^{\circ}\text{C}$  dan  $16\text{ }^{\circ}\text{C}$  ga ko'tarildi. Endi harorat qancha bo'ldi?

c) Harorat  $0\text{ }^{\circ}\text{C}$  dan  $4\text{ }^{\circ}\text{C}$  ga pasaydi. Endi harorat qancha bo'ldi?

d) Harorat  $-8\text{ }^{\circ}\text{C}$  dan  $4\text{ }^{\circ}\text{C}$  ga ko'tarildi. Endi harorat qancha bo'ldi?



Bir xil ishorali butun sonlarni quyidagi tartibda ham qo'shish mumkin:

- ularning modullari qo'shiladi;

- qo'shiluvchilar musbat bo'lsa,

yig'indi oldiga "+", manfiy bo'lsa,

"-" ishorasi qo'yiladi.

$$46 + (+17) = |46| + |+17| = 46 + 17 = 63$$

$$-69 + (-79) = -(|-69| + |-79|) = -(69 + 79) = -148$$

$$n + 0 = n$$

$$-n + 0 = -n$$

4. Hisoblang.

a)  $-12 + (-13)$

b)  $0 + (-6)$

c)  $47 + (+131)$

d)  $-16 + (-14)$

5. Ifodaning qiymatini toping.

a)  $|x| + |-25|$ , bu yerda  $x = -25$

c)  $|a| - |b|$ , bu yerda  $a = -150$ ,  $b = -138$

b)  $|a| + |-15|$ , bu yerda  $a = -33$

d)  $|a| - |b| + |c|$ , bu yerda  $a = 27$ ,  $b = 87$ ,  $c = 95$

6. Abror 1 668 000 so'm va 2 454 000 so'mga ikkita kompyuter sotib oldi. U jami qancha pul sarfladi?





### Mustahkamlash: 7–11.

7. Hisoblang.

a)  $-13 + (-19)$

b)  $-26 + (-76)$

c)  $100 + 300$

d)  $-143 + (-155)$

e)  $-314 + (-112)$

f)  $-55 + (-29)$

8. Sonlar o'qidan foydalanib qo'shing.

a)  $(+6) + (+2)$

b)  $(-10) + (-1)$

c)  $(+9) + 0$

d)  $(-2) + (-8)$

$(-6) + (-2)$

$(+10) + (+1)$

$(-9) + 0$

$(+2) + (+8)$

9. O'yindagi o'zaro qarama-qarshi sonlarning barchasini toping.



10. 2021-yilda bir mamlakat aholisi 906 450 600 kishi bo'lgan bo'lsa, keyingi yili 9 889 700 kishiga ko'paydi. 2022-yilda bu davlatning aholisi qancha bo'ladi?

11. Bir xil ishorali sonlarni ustun shaklida qo'shing.

$(-492)$   
 $+( -614)$

$(-939)$   
 $+( -301)$

$(-291)$   
 $+( -992)$

$(-782)$   
 $+( -488)$

$(-526)$   
 $+( -625)$

$(-388)$   
 $+( -883)$



$(-6) + 4 = -2$

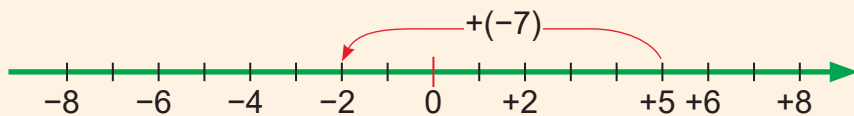
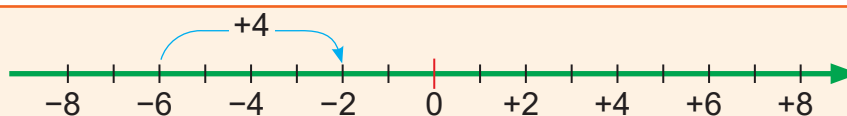

$5 + (-7) = -2$

Turli ishorali butun sonlarni qo'shish uchun ikkinchi qo'shiluvchi musbat bo'lsa, o'ng tomonga, manfiy bo'lsa, chap tomonga qo'shiluvchining moduli miqdoricha birlik siljitamiz.



### Guruhlarda ishlaymiz: 12–16.

12. Sonlar o'qidan foydalanib qo'shing.

a)  $7 + (-5)$

b)  $0 + (-9)$

c)  $(-8) + 3$

d)  $(-1) + 0$

e)  $(-1) + 7$

f)  $3 + (-6)$

g)  $(-10) + 5$

h)  $0 + (-11)$

13. Bir kunlik aholi soni bo'yicha statistik ma'lumot tayyorlandi. 368 427 nafar aholisi bor tumanda shu kuni 17 ta tug'ilish va 4 ta o'lim qayd etildi. Bir kunda tuman aholisi soni qanchaga o'zgardi?



Turli ishorali butun sonlarni quyidagi tartibda ham qo'shish mumkin:

- moduli kattasidan moduli kichigi ayriladi;
- ayirmaning oldiga moduli katta butun sonning ishorasi qo'yiladi.

$$-38 + (+28) = |-38| - |+28| = -10$$

$$146 + (-80) = |146| - |-80| = 66$$

$$-123 + (+24) = |-123| - |+24| = -99$$

14. Hisoblang.

a)  $12 + (-4)$

b)  $-27 + 29$

c)  $-79 + 19$

d)  $16 + (-81)$

e)  $44 + (-55)$

f)  $-77 + (-77)$

15. Qaysi ifodalarning natijasi manfiy yoki musbat ekanini hisoblamasdan toping.

a)  $122 + (-4)$

b)  $-270 + 209$

c)  $-709 + 109$

d)  $(-33) + (-7)$

e)  $(-212) + (-66)$

f)  $(-88) + (-40)$



$$145 + (-41) = -41 + 145$$

$$-87 + (-57) = -57 + (-87)$$

$$-144 + (-15) + (-85) = -144 + (-15 + (-85)) = -144 + (-100) = -244$$

$$77 + (-17) + (-10) = (77 + (-17)) + (-10) = 60 + (-10) = 50$$

16. Hisoblang.

a)  $-15 + (-15) + (-15) + (-15)$

b)  $-12 + 19 + (-18) + (-11)$

c)  $-39 + (-12) + 12 + 21$

d)  $16 + 12 + 12 + (-14)$



**Qiziqarli matematika: 17.**

17. Beshta 5 raqami, arifmetik amallar va qavsdan foydalanib  $-555$ ,  $-55$ ,  $-5$ ,  $0$ ,  $5$ ,  $55$ ,  $555$  sonlarini hosil qila olasizmi?

**5, 5, 5, 5, 5**



**Mustahkamlash: 18-23.**

18. Sonlar o'qiga mos ifodalarni toping va hisoblang.

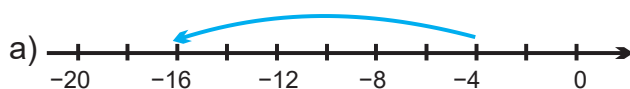

$-16 + (4)$

$-4 + (-12)$

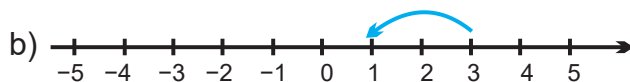

$3 + (-2)$

$3 + (-1)$

19. Bo'sh joylarni to'ldiring.

a)  $(-16) + \underline{\quad} = -13$

b)  $13 + \underline{\quad} = -16$

c)  $(-18) + \underline{\quad} = -14$

d)  $18 + \underline{\quad} = 0$

e)  $\underline{\quad} + (-19) = -17$

f)  $(-16) + \underline{\quad} = -18$

20. Ifodalar qiymatini  $x = 5$ ,  $y = -3$  va  $z = 7$  bo'lganda toping.

a)  $(-y) + 20$

b)  $(-z) + x + (-16)$

c)  $x + 15 + (-x)$

21. Barcha temperaturalar  $8^\circ$  ga ko'tarilsa, ko'rsatkichlar qanday o'zgaradi?

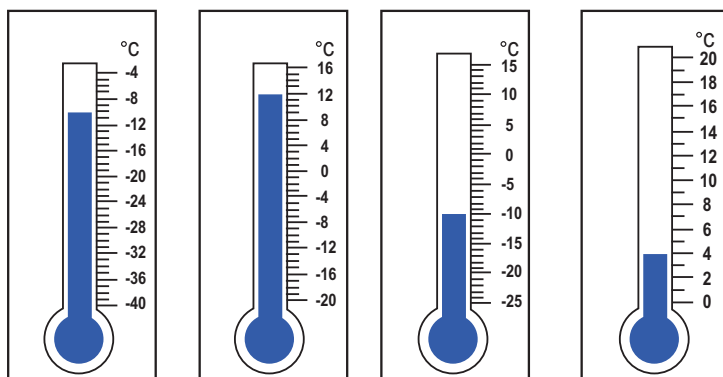

22. Butun sonlarni qo'shing.

$$\begin{array}{r} (-814) \\ +(-974) \\ \hline \end{array}$$

$$\begin{array}{r} (-423) \\ +(-433) \\ \hline \end{array}$$

$$\begin{array}{r} 399 \\ +(-931) \\ \hline \end{array}$$

$$\begin{array}{r} 390 \\ +(-991) \\ \hline \end{array}$$

$$\begin{array}{r} 966 \\ + 348 \\ \hline \end{array}$$

23. Qulay usullarda hisoblang.

a)  $-14 + (-9) + (-11)$

b)  $-21 + (-19) + 13$

c)  $-11 + (-18) + (-19)$

d)  $-18 + 15 + 12$

e)  $12 + (-15) + (-10)$

f)  $-15 + (-18) + (-15)$



### Mustaqil ish: 24-27.

24. Yig'indilar nimaga teng?

a)  $0 + (-44)$

b)  $-55 + (-55)$

c)  $-88 + (-22)$

d)  $-145 + (-145)$

25. Hisoblang.

a)  $112 + 144$

b)  $125 + 100$

c)  $-16 + 0$

d)  $-99 + (-100)$

e)  $-33 + (-37)$

f)  $-754 + (-99)$

g)  $-17 + (-77)$

h)  $-37 + (-25)$

26. Jadvallarni to'ldiring.

1	+	-12	6
	-3		
	7		

2	+	5	-2
	-9		
	24		

3	+	-14	-8
	14		
	1		

4	+	-16	-5
	-10		
	-17		

27. Qulay usul bilan hisoblang.

a)  $1 + (-2) + 3 + (-4) + 5 + (-6) + 7 + (-8)$

b)  $-37 + (-22) + (-13)$

c)  $-3 + 5 + (-7) + 9 + (-11) + 12 + (-18) + 26$

d)  $42 + (-45) + (-12)$



$$+5 - (+2) = 3$$

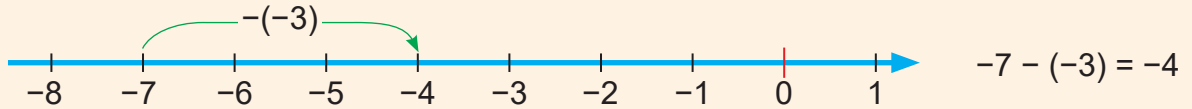
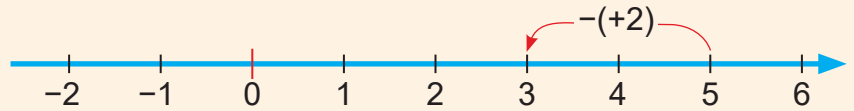

Bir xil ishorali butun sonlarni ayirish uchun ayriluvchi musbat bo'lsa, chap tomonga, manfiy bo'lsa, o'ng tomonga ayriluvchining moduli miqdoricha birlik siljitamiz.



### Guruhlarda ishlaymiz: 1-3.

1. Sonlar o'qidan foydalanib ayiring.

a)  $(+10) - (+3)$

b)  $(+9) - (+1)$

c)  $(+6) - 2$

d)  $(+4) - (+2)$

e)  $(-7) - (-1)$

f)  $(-8) - (-5)$

g)  $(-2) - 0$

h)  $(-10) - (-10)$

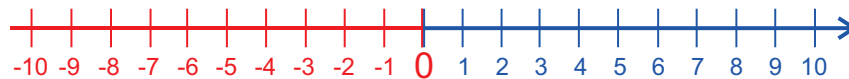

2. Bo'sh joylarni to'ldiring.

a)  $-16 + \dots = 0$

b)  $28 + \dots = 0$

c)  $45 - 45 = \dots$

d)  $-3 + \dots = -2$

e)  $\dots - 6 = -4$

f)  $-9 - \dots = -2$

3. Solihaning telefoni 27 000 so'mlik tarifda. Uning telefon hisob raqamiga otasi 15 000 so'm o'tkazdi. Telefon tarifi uchun yana qancha to'lash kerak?



### Mustahkamlash: 4-6.

4. Butun sonlarni ayiring.

a)  $-81 - (-18)$

b)  $-13 - (-44)$

c)  $-12 - (-77)$

d)  $+26 - (+22)$

e)  $-16 - (-71)$

f)  $-18 - (-28)$

g)  $-24 - (-33)$

h)  $-10 - (-41)$

5. Butun sonlarni qo'shing.

a)  $-13 + 5 + (-4) + (-5)$

b)  $12 + 7 + (-13) + 18$

c)  $-13 + 8 + 11 + (-13)$

d)  $1 + (-20) + (-16) + 4$

e)  $20 + (-6) + (-5) + 17$

f)  $-12 + (-19) + (-5) + (-4)$

6. Jadvalni to'ldiring.

$a$	$b$	$a + b$	$a - b$
-4	-2	-6	
-9	-3		
-8		-16	
-20			-15



### Qiziqarli matematika: 7.

7. Ixtiyoriy 9 ta manfiy sonni shunday joylashtiringki, ustuni va satrlarining yig'indisi a)  $-6$ ; b)  $-15$ ; c)  $-20$  ga teng bo'lsin. Sonlar takrorlanishi mumkin.

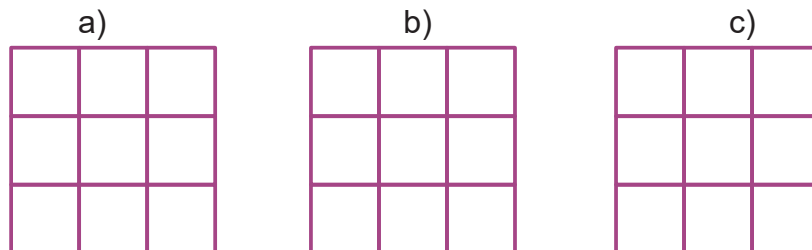

Turli ishorali butun sonlarni ayirish uchun kamayuvchiga ayriluvchiga qarama-qarshi sonni qo'shish kerak.

$$k - n = k + (-n)$$

$$k - (-n) = k + n$$



$$-74 - 84 = -74 + (-84) = -158$$

$$66 - (-45) = 66 + 45 = 111$$

$$n - 0 = n$$

$$-n - 0 = -n$$

$$0 - n = -n$$



### Guruhlarda ishlaymiz: 8-11.

8. Ayirmalar nimaga teng?

a)  $-6 - 5$

b)  $-3 - 8$

c)  $-5 - 19$

d)  $-6 - 30$

e)  $-4 - 3$

f)  $-24 - 22$

g)  $-29 - 24$

h)  $-12 - 24$

9. Hisoblang.

a)  $-7 - (+13)$

b)  $-5 - (+8)$

c)  $-29 - (+21)$

d)  $-8 - (+5)$

e)  $8 - (-8)$

f)  $14 - (-19)$

g)  $3 - (-14)$

h)  $12 - (-24)$

10. Modellarga mos ifodalar tuzib, qiymatini toping.

a)



b)

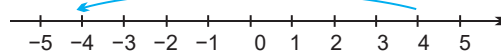

c)

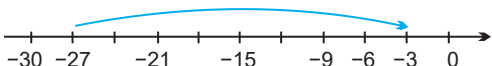

d)

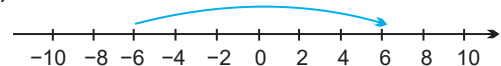

11. Ifodalarni taqqoslang.

a)  $8 - (-18) \bigcirc -3 - (-4)$

b)  $-12 - 7 \bigcirc 26 - (-22)$

c)  $6 - (-7) \bigcirc -8 - (-28)$

d)  $24 - (-3) \bigcirc -10 - (-1)$



### Qiziqarli matematika: 12–13.

12. Qanday qonuniyatlar berilgan? Xulosangizni tushuntiring.

$$+ - - = +$$

$$- - - = +$$

$$- - + = -$$

$$+ - + = -$$

$$+ - + = +$$

$$- - - = -$$

13.  $2 * 4 * 6 * 8 * 10 * 12 * 14 * 16$  ifodadagi yulduzchalar o'rniga "+" yoki "-" ishoralarini qo'yib,  $-80, 15, 10, -16$  sonlaridan qaysilarini hosil qilish mumkin?



### Mustahkamlash: 14–19.

14. Bo'sh joylarni to'ldiring.

a)  $-3 + \underline{\quad} + 7 = -2$

b)  $4 + (-7) + \underline{\quad} = 5$

c)  $\underline{\quad} + (-1) + (-9) = -20$

d)  $\underline{\quad} + (-5) + (-3) = -4$

e)  $\underline{\quad} + (-6) + (-8) = -4$

f)  $(-2) + (-3) + \underline{\quad} = 1$

15. Savollarga javob yozing.

1-savol. Yarim tunda Toshkentda havo harorati  $-2^\circ\text{C}$  edi. Ertalab soat 9 da  $5^\circ\text{C}$  bo'ldi. Harorat necha darajaga ko'tarildi?

2-savol. Odilning telefon hisob raqamida  $-2750$  so'm bor. Agar u  $10000$  so'm to'lasa, hisobida qancha pul bo'ladi?

16. Bo'sh kataklarni to'ldiring.

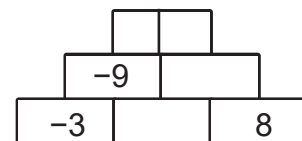
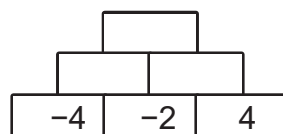
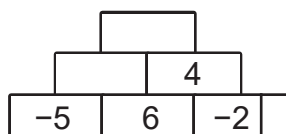

17. Nuqtalar orasidagi masofani toping.

a) A(-7) va B(-3)

b) C(-12) va D(+12)

c) E(0) va G(+8)

d) K(-16) va L(-9)

e) F(-10) va M(+6)

f) N(0) va P(-5)

18. Hisoblang.

a)  $-6 + 7 - 8 + 9 - 10 + 11 - 12 + 13 - 14 + 15 - 16 + 17 - 18 + 19 - 20$

b)  $22 - 23 + 23 - 24 + 24 - 25 + 25 - 26 + 26 - 27 + 27 - 28 + 28$

c)  $1 - 2 + 3 - 4 + 5 - 6 + 7 - 8 + 9 - 10 + \dots + 99 - 100$

19. Bo'sh joylarni to'ldiring.

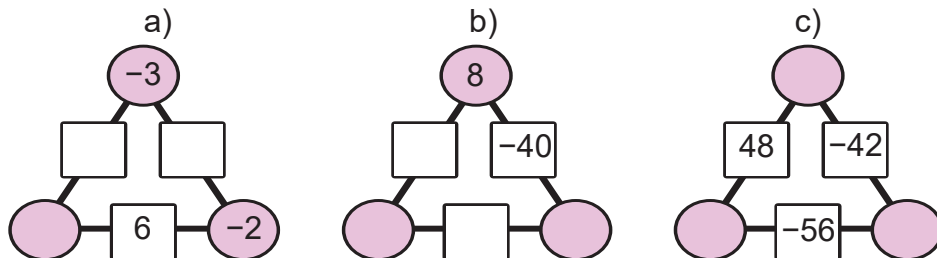

Mustaqil ish: 20–24.

20. Mos sonlarni qo'yib natijani tenglang.

a)  $\square + \square = -2$   
 $\square - \square = 10$   
 $\square + \square = 2$

$\{-6, -4, -4, 4, 6, 6\}$

b)  $\square - \square = 0$   
 $\square + \square = -5$   
 $\square - \square = -3$

$\{-4, -3, -3, -1, 2, 5\}$

21. Quyidagilarni ayiring.

- a) +10 dan +15 ni      b) +1 dan -9 ni      c) -33 dan +27 ni      d) -20 dan -16 ni  
 e) -21 dan -8 ni      f) -12 dan +6 ni      g) 0 dan -8 ni      h) -3 dan -6 ni

22. Bo'sh kataklarni to'ldiring.

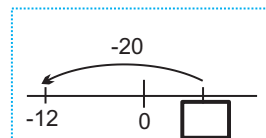
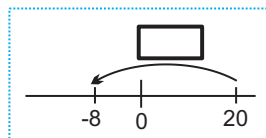
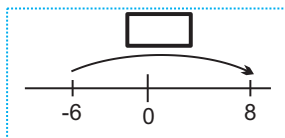
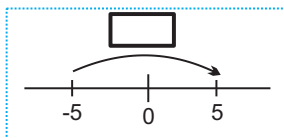

23. Hisoblang.

- a)  $(2 - 4) + (6 - 8) + (10 - 12) + (14 - 16) + (18 - 20) + \dots + (98 - 100)$   
 b)  $(1 + 3) - (5 + 7) - (9 + 11) - \dots - (97 + 99)$

24. Son o'qidan foydalanib hisoblang.

- a)  $6 + (-3)$       b)  $+4 - (+2)$       c)  $8 + (+1)$       d)  $-2 + (+4)$       e)  $-3 - (-4)$   
 f)  $-10 + (+10)$       g)  $6 - (+6)$       h)  $-3 + (-2)$       i)  $-1 + (+2)$       j)  $-7 - (+4)$

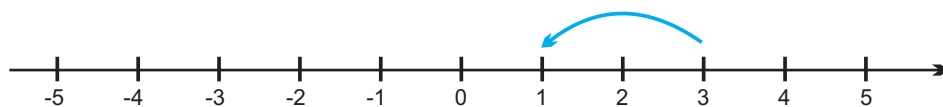

$+3 - (+2) = ?$

$+3 + (+2) = ?$

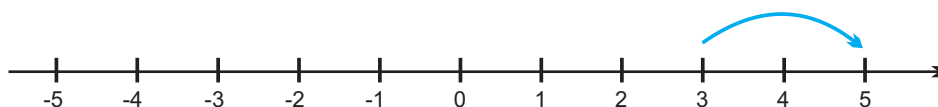



Butun sonlarni ko'paytirishda:

Misol	Ifoda	Natija
$14 \times 12 = 168$	musbat son $\times$ musbat son	musbat
$-14 \times (-12) = 168$	manfiy son $\times$ manfiy son	musbat
$-14 \times 12 = -168$	manfiy son $\times$ musbat son	manfiy
$14 \times (-12) = -168$	musbat son $\times$ manfiy son	manfiy

$$n \times 0 = 0 \quad 0 \times n = 0$$

$$n \times (-1) = -n \quad (-1) \times n = -n$$



Guruhlarda ishlaymiz: 1-3.

1. Butun sonlarni ko'paytiring.

- a)  $18 \times (-6)$       b)  $-7 \times (-1)$       c)  $8 \times (-1)$       d)  $(-8) \times (-3)$   
 e)  $(-2) \times (-9)$       f)  $-16 \times 4$       g)  $-16 \times (-2)$       h)  $(-5) \times (-7)$

2. Jadvalni to'ldiring.

$\times$	-11	12	-2
-9			
7			
-6			

$\times$	9	-10	1
-7			
-9			
3			

$\times$	-12	8	-9
5			
-6			
-7			

3.  $-9, -7, -5, 2, 4, 6$  sonlar orasidan ixtiyoriy ikkitasi tanlab olindi va bir-biriga ko'paytirildi. Eng kichik son nechaga teng bo'lishi mumkin?



Mustahkamlash: 4-9.

4. Hisoblang.

- a)  $23 \times 49$       b)  $19 \times 30$       c)  $-77 \times 65$       d)  $-22 \times 16$   
 e)  $12 \times (-95)$       f)  $-19 \times (-21)$       g)  $72 \times 36$       h)  $-39 \times (-43)$

5. Noma'lumlarni toping.

- a)  $(-9) \times \underline{\hspace{2cm}} = -36$       b)  $(-4) \times \underline{\hspace{2cm}} = (-12)$       c)  $\underline{\hspace{2cm}} \times 5 = 20$   
 d)  $3 \times \underline{\hspace{2cm}} = 15$       e)  $\underline{\hspace{2cm}} \times 0 = 0$       f)  $(-4) \times \underline{\hspace{2cm}} = 4$







Butun sonlarni bo'lishda:

Misol	Natija	Ifoda
$168 \div 12 = 14$	musbat	musbat son $\div$ musbat son
$-168 \div (-12) = 14$	musbat	manfiy son $\div$ manfiy son
$-168 \div 12 = -14$	manfiy	manfiy son $\div$ musbat son
$168 \div (-12) = -14$	manfiy	musbat son $\div$ manfiy son

~~$0 \div 0$~~

$0 \div n = 0$

~~$n \div 0$~~

$n \div (-1) = -n$



Guruhlarda ishlaymiz: 1-3.

1. Butun sonlarni bo'ling.

a)  $-6 \div 1$

b)  $-24 \div 6$

c)  $-7 \div 1$

d)  $-7 \div 7$

e)  $-54 \div 9$

f)  $-36 \div 4$

j)  $9 \div (-3)$

h)  $-1 \div (-1)$

k)  $-28 \div (-4)$

l)  $9 \div (-9)$

2. Noma'lumlarni toping.

a) \_\_\_\_\_  $\div (-9) = 7$

b) \_\_\_\_\_  $\div 7 = (-12)$

c)  $(-99) \div$  \_\_\_\_\_  $= 11$

d) \_\_\_\_\_  $\div 9 = (-1)$

e)  $54 \div$  \_\_\_\_\_  $= 9$

f)  $63 \div$  \_\_\_\_\_  $= (-7)$

g) \_\_\_\_\_  $\div 7 = 10$

h) \_\_\_\_\_  $\div (-4) = 8$

i)  $(-60) \div$  \_\_\_\_\_  $= (-10)$

3. Natijasi o'zaro teng bo'lgan ifodalarni belgilang.

$21 \div 7$

$-21 \div 7$

$10 \div 5$

$21 \div (-7)$

$-21 \div (-7)$

$10 \div (-5)$

$63 \div (-9)$

$-10 \div (-5)$

$-10 \div 5$



Mustahkamlash: 4-9.

4. Berilgan sonlardan foydalanib tengliklar tuzing.

24

-12

-3

-4

-48

-6

2

-8

a) \_\_\_\_\_  $\div$  \_\_\_\_\_  $= -6$

b) \_\_\_\_\_  $\div$  \_\_\_\_\_  $= 3$

c) \_\_\_\_\_  $\div$  \_\_\_\_\_  $= -24$

d) \_\_\_\_\_  $\times$  \_\_\_\_\_  $= -96$

e) \_\_\_\_\_  $\times$  \_\_\_\_\_  $= -96$

f) \_\_\_\_\_  $\div$  \_\_\_\_\_  $= -4$

5. Hisoblang.

a)  $(-12) \div 2$

b)  $(-32) \div 4$

c)  $(-20) \div 5$

d)  $30 \div (-6)$

e)  $(-16) \div 4$

f)  $42 \div (-7)$

g)  $(-12) \div 2$

h)  $(-36) \div (-3)$

i)  $(-50) \div 10$

j)  $(-88) \div 11$

k)  $30 \div (-5)$

l)  $(-72) \div (-6)$

6. Hisoblang va bo'sh kataklarni to'ldiring.

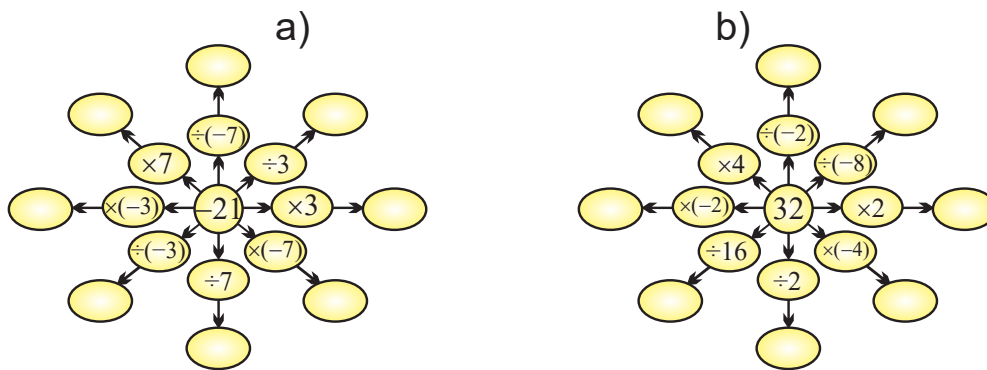

7. Noma'lum tarkibiy qismlarni toping.

a)  $\square \times (-5) = -85$       b)  $\square \div 22 = -4$       c)  $\square \times (-13) = 52$   
 d)  $-8 \times 12 = \square$       e)  $70 \div (-35) = \square$       f)  $-44 \div \square = -2$

8. Muzlatilgan go'shtning harorati  $-18^\circ\text{C}$  darajada edi. Go'shtni mikroto'lqinli pechda  $15^\circ\text{C}$  isitish kerak. Agar har minutda go'sht  $3^\circ\text{C}$  ga isib borsa, pechni qancha vaqtga to'g'rilash kerak?

9. Bo'sh kataklarni to'ldirib, xulosalarimizni yozing.

$\times$	-4	-3	-2	-1	0	1	2	3	4
-4					0				
-3					0				
-2					0				
-1					0				
0	0	0	0	0	0	0	0	0	0
1					0				
2					0				
3					0				
4					0				



**Mustaqil ish: 10.**

10. Sonlarning mosini qo'yib to'g'ri tenglik hosil qiling.

$\square - \square = \square$	$\square - \square = \square$
$\square + \square = \square$	$\square + \square = \square$
$\square \times \square = \square$	$\square \times \square = \square$
$\square \div \square = \square$	$\square \div \square = \square$

-4	-8	-15	6	8	-7	-4	9	-11	-7	12	-17
12	-10	-7	-80	-2	-11	-16	-10	-132	-36	-7	8

## BUTUN SONLAR USTIDA TOPSHIRIQLAR



## Eslaymiz!

$10 + (+5) = ?$

$-10 + (+5) = ?$

$10 - (+5) = ?$

$-10 - (+5) = ?$

$10 + (-5) = ?$

$-10 + (-5) = ?$

$10 - (-5) = ?$

$-10 - (-5) = ?$

$10 \times (+5) = ?$

$-10 \times (+5) = ?$

$10 \div (+5) = ?$

$-10 \div (+5) = ?$

$10 \times (-5) = ?$

$-10 \times (-5) = ?$

$10 \div (-5) = ?$

$-10 \div (-5) = ?$

Hisoblashlar qanday amalga oshirilgan? Xulosangizni bildiring.

$1) 42 \times 31 - 38 \times 42 + 21 \times 16 = 42$

$2) 21 \times 74 + 21 \times 11 - 85 \times 10 = 935$

$3) -128 \times 39 + 78 \times 32 + 64 \times 59 = 1280$



## Guruhlarda ishlaymiz: 1-3.

1. Noma'lumlarni toping.

$a) -15 \times 4 = \square$

$b) \square \div (-12) = 6$

$c) 49 \div \square = -7$

$d) -48 \div \square = -8$

$e) 16 \times (-4) = \square$

$f) \square \times (-8) = 88$

2. Ketma-ketlik asosida ifoda tuzamiz va hisoblang.

$a) 0,2 \xrightarrow{\times(-3)} \square \xrightarrow{\div 2} \square \xrightarrow{-1} \square \xrightarrow{\times(-1)} \square \xrightarrow{-1} \square$

$b) -66 \xrightarrow{\div 3} \square \xrightarrow{-8} \square \xrightarrow{\times(-4)} \square \xrightarrow{\times(-1)} \square \xrightarrow{+1} \square$

3. Zafarning uyi ko'chaning o'rtasida joylashgan va ko'cha boshidan sanaganda 11-uy hisoblanadi. Zulayhoning uyi esa ko'chaning oxiridan sanaganda 6-uy. Ko'chaning boshidan sanasak, Zulayhoning uyi nechanchi uyga to'g'ri keladi?



## Mustahkamlash: 4-10.

4. Bo'sh kataklarni to'ldiring.

a)

-5	+	2	=	<input type="text"/>
+		+		
-3	+	-1	=	<input type="text"/>
=		=		
<input type="text"/>		<input type="text"/>		

b)

5	-	-3	=	<input type="text"/>
+		-		
-6	+	-2	=	<input type="text"/>
=		=		
<input type="text"/>		<input type="text"/>		

c)

-4	+	-3	=	<input type="text"/>
-		+		
-4	-	-3	=	<input type="text"/>
=		=		
<input type="text"/>		<input type="text"/>		

5. Sport maydonchasida o'ynash uchun bitta mahalladan 13 nafar, ikkinchisidan 19 nafar bola to'plandi. Keyin yana bir nechta bola uchinchi mahalladan qo'shilgach, ular teng 6 ta jamoaga bo'linib, o'yin boshladi. Uchinchi mahalladan eng kamida nechta bola o'yinga qo'shilgan bo'lishi mumkin?
6. Maktabga kirish darvozasi teng uzunlikdagi ikkita to'siq bilan yopilishi mumkin. Har bir to'siqning uzunligi 475 cm. To'siqlar yopilganda bir-birining ustiga chiqadigan qismlarning uzunligi 92 cm. Maktabning kirish eshigi uzunligi necha santimetrga teng?

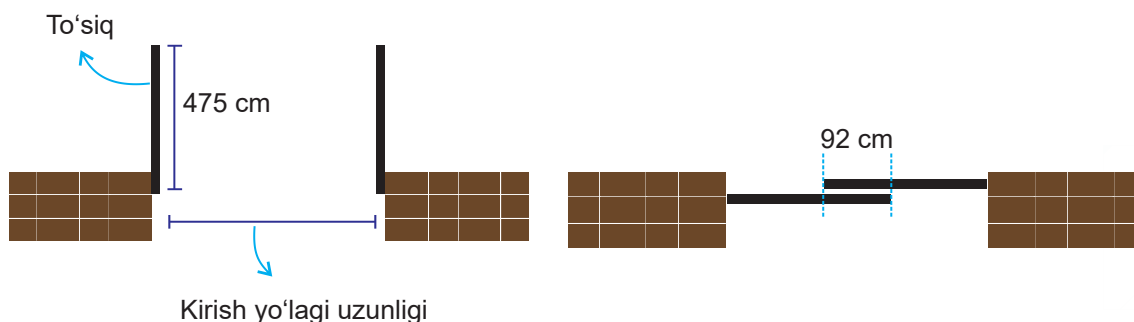

7. Qonuniyatni aniqlab, bo'sh kataklarni to'ldiring.

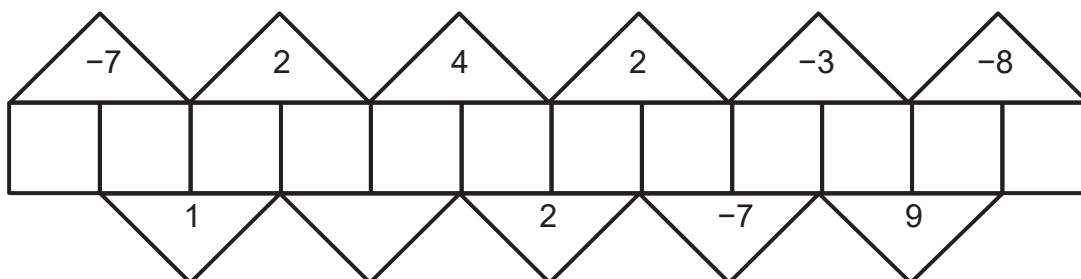

8. Hisoblang.

a)  $[-9 - (2 - 5)] \div (-6)$

b)  $-6 + (-3 - 3)^2 \div |3|$

c)  $4 - 2|3^2 - 16|$

d)  $(-7 - 5) \div [-2 - 2 - (-6)]$

f)  $(-10 - 6) \div (-2)^2 - 5$

9. Hisoblang va jadvalni to'ldiring.

$k$	-1	1	-1	15	20	-28	-32	45	-72	18	-24
$n$	1	-1	-1	-3	-4	-7	8	-15	4	-2	6
$k + n$	0										
$k - n$	-2										
$k \times n$	-1										
$k \div n$	-1										

10. Laylo opa 5 ta farzandining har biri uchun teng miqdorda shirinlik tayyorladi. Lekin kenjatoy farzandi uni yeyishni xohlamadi, shuning uchun Laylo opa shirinlikning bittasini o'zi yedi va qolganlarini boshqa farzandlariga teng taqsimlab berdi. Agar pishiriqlar soni 10 tadan ko'p va 40 tadan kam ekani ma'lum bo'lsa, jami nechta pishiriq pishirilganini toping.



### Mustaqil ish: 11–16.

#### 11. Hisoblang.

$$a) [2+4|7+2^2|] \div [4 \times 2 + 5 \times 3]$$

$$b) -4 - [2 + 4(-6) - 4 - 22 - 5 \times 2]$$

$$c) [6 \times 2 + 2 - (-6)](-5 + |(-18 \div 6)|)$$

$$d) 2 \times (-3) + 3 - 6[-2 - (1-3)]$$

#### 12. Savollarga javob yozing.

a) Payshanba kuni havo harorati  $-7^\circ\text{C}$  edi, ertasi kuni  $9^\circ\text{C}$  ko'tarildi. Ertasi kuni harorat qanday bo'ldi?

b) Toshkentda havo harorati  $-5^\circ\text{C}$ , Urganchda  $-8^\circ\text{C}$ . Haroratlar o'rtasidagi farq nechaga teng?

c)  $2^\circ\text{C}$  harorat  $-2^\circ\text{C}$  haroratdan qancha ko'p?

d) Yakshanba kuni havo harorati  $4^\circ\text{C}$  edi, ertasi kuni  $11^\circ\text{C}$  ga pasaydi. Ertasi kuni havo harorati qanday bo'ldi?

#### 13. Yashirilgan natijalarni toping.

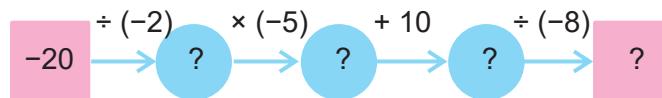

#### 14. Butun sonlarni o'sish tartibida yozing.

- |    |     |     |     |     |     |      |
|----|-----|-----|-----|-----|-----|------|
| a) | -9  | +3  | -23 | +6  | -7  |      |
| b) | -28 | +33 | -35 | +31 | -37 |      |
| c) | +8  | -13 | -19 | 0   | +11 | -15  |
| d) | -15 | 0   | +14 | -17 | +16 | -19. |

#### 15. Yozing.

a)  $-5$  dan katta, lekin  $0$  dan kichik  $4$  ta son

b)  $-6$  dan katta, lekin  $1$  dan kichik  $5$  ta son

#### 16. Sonlar o'qiga mos ifodalar tuzing va hisoblang.

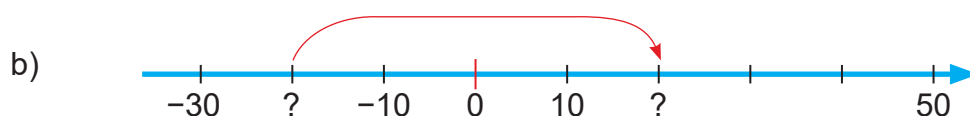
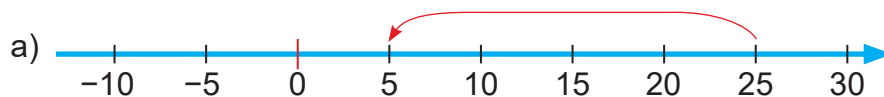

# V bob

## RATSIONAL SONLAR

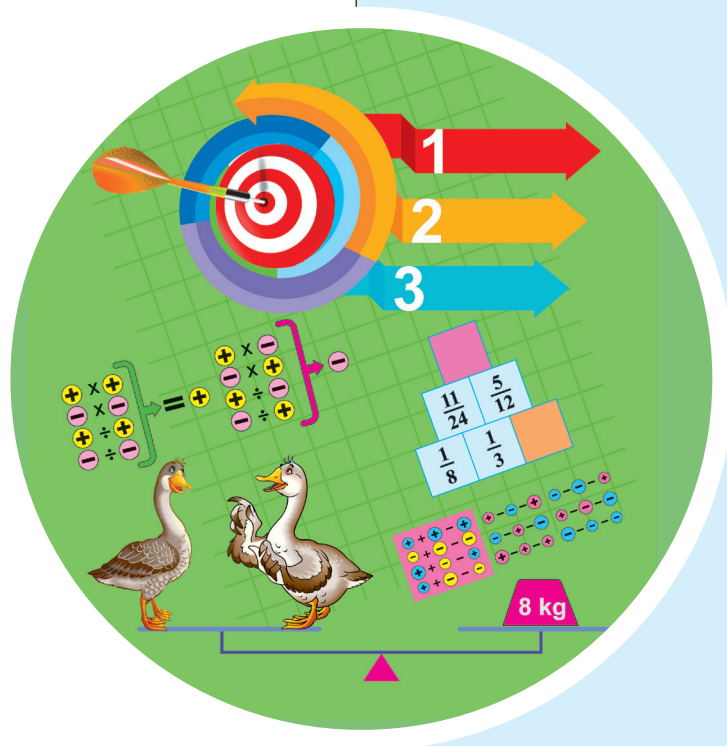

## RATSIONAL SON HAQIDA TUSHUNCHA



### Eslaymiz!

Natural sonlar = { 1, 2, 3, 4, 5, 6, 7, 8, 9, 10, 11, 12, 13, ... }

Butun sonlar = { ..., -4, -3, -2, -1, 0, 1, 2, 3, 4, ... }

Natural sonlar:  $2 = \frac{2}{1}$ ;  $11 = \frac{11}{1}$ ;

Butun sonlar:  $-15 = -\frac{15}{1}$ ;  $0 = \frac{0}{7}$ ;

Chekli o'nli kasrlar:  $0,41 = \frac{41}{100}$ ;  $-17,127 = -17 \frac{127}{1000}$ ;

Cheksiz davriy o'nli kasrlar:  $0,(5) = \frac{5}{9}$ ;  $7,21(327) = 7 \frac{21306}{99900} = 7 \frac{3551}{16650}$ ;

Demak, barcha sonlarni  $\frac{p}{q}$  ko'rinishida yozish mumkin.



Har qanday qisqarmas  $\frac{p}{q}$  kasr ko'rinishida yozish mumkin bo'lgan barcha sonlar **ratsional sonlardir**.

$p$  – butun son

$q$  – natural son

Barcha butun sonlar ratsional sonlar hisoblanadi.

Istalgan  $p$  butun sonni quyidagicha yozish mumkin:

$$p = \frac{p}{1}$$



$\frac{8}{16} = \frac{4}{8} = \frac{2}{4}$  kasrlar ham ratsional sonidir, chunki bular  $\frac{1}{2}$  qisqarmas kasrga teng.

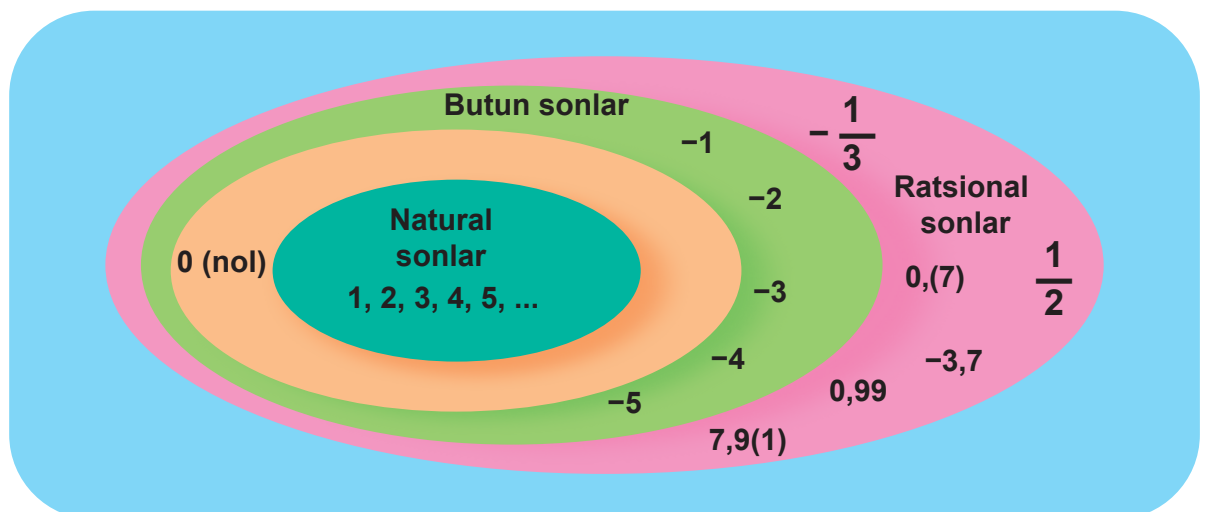

$0 = \frac{0}{1} = \frac{0}{2} = \frac{0}{-3} = \dots$  0 sonining ratsional ko'rinishi





## Guruhlarda ishlaymiz: 1-7.

1. Natijalarni tahlil qiling va xulosangizni bildiring.

$p$	$q$	$\frac{p}{q}$	=
1	1	$\frac{1}{1}$	1
-55	100	$\frac{-55}{100}$	-0,55
1	1000	$\frac{1}{1000}$	0,001
-253	10	$\frac{-253}{10}$	-25,3
7	0	$\frac{7}{0}$	Yo'q! "q" nol bo'lishi mumkin emas!

2. Sonlarni oddiy kasr ko'rinishida yozing.

- a) 2      5      -1  
 b) 0,7      1,41      -11,01      -5,00023  
 c) 0,(3)      -0,(9)      2,(411)      -14,(42)

Yodda tuting!

$$\frac{-p}{q} = \frac{p}{-q} = -\frac{p}{q}$$

3. Sonlarni maxrajli natural son bo'lgan oddiy kasr ko'rinishida yozing.

$$\frac{1}{-5} \quad \frac{-7}{-8} \quad \frac{5}{-11} \quad \frac{-3}{25} \quad \frac{15}{-19} \quad \frac{-2}{-13}$$

4. Sonlarning qaysilari natural son bo'la oladi? Ajratib yozing.

$$\frac{7}{3} \quad \frac{8}{4} \quad \frac{-16}{2} \quad \frac{72}{10} \quad \frac{-150}{-5} \quad \frac{9}{10}$$

5. Ratsional sonlarni oddiy kasr ko'rinishida yozing.

$$-1 \quad 7 \quad 0 \quad -88 \quad -1\frac{5}{6} \quad -2\frac{1}{2} \quad 0,42 \quad -171,01$$

6.  $x$  o'rniga shunday son qo'yingki, natijada to'g'ri tenglik hosil bo'lsin.

a)  $\frac{-17}{51} = \frac{1}{x}$       b)  $\frac{x}{5} = \frac{-22}{-110}$       c)  $\frac{-x}{21} = \frac{1}{3}$

7. Qisqartiring va musbat maxrajli kasr ko'rinishida yozing.

a)  $\frac{-18}{54}$       b)  $\frac{-12}{-96}$       c)  $\frac{6}{-186}$       d)  $\frac{-65}{-39}$



### Mustahkamlash: 8–12.

8. Jadvalda berilgan mahsulotlardagi temir moddasini grammda ifodalang.

Mahsulotlar (100 g)	Temir moddasi (mg)	Ratsional son (g)
Dukkakli mahsulotlar	6	
Jigar go'shti	7	
Ismaloq	13,5	

9.  $x$  o'rniga shunday son qo'yingki, natijada to'g'ri tenglik hosil bo'lsin.

a)  $\frac{-7}{14} = \frac{1}{x}$       b)  $\frac{x}{5} = \frac{-2}{-0}$       c)  $\frac{-x}{3} = \frac{1}{3}$       d)  $\frac{4}{-x} = \frac{8}{32}$

10. Qisqartiring va musbat maxrajli kasr ko'rinishida yozing.

a)  $\frac{-8}{16}$       b)  $\frac{-12}{-24}$       c)  $\frac{6}{-18}$       d)  $\frac{-25}{-45}$       e)  $\frac{-12}{16}$

11. Taqqoslang.

a)  $\frac{25}{37}$  va  $\frac{47}{74}$       b)  $\frac{-7}{16}$  va  $\frac{-5}{16}$       c)  $\frac{-5}{6}$  va 0      d)  $\frac{7}{-8}$  va  $\frac{-8}{7}$

12. Hisoblang va natijani  $\frac{p}{q}$  ko'rinishida yozing ( $p$  – butun son,  $q$  – natural son).

a)  $1 - \frac{1}{2}$       b)  $-\frac{2}{3} + \frac{5}{6}$       c)  $5\frac{4}{7} + (-2\frac{1}{7})$       d)  $4,7 + 5,2$



### Mustaqil ish: 13–16.

13. Hisoblang.

a)  $1 - \frac{19}{33}$       b)  $2 - \frac{77}{97}$       c)  $19 - 18\frac{23}{24}$       d)  $2021 - \frac{2022}{2023}$

14. Ratsional son ko'rinishida yozing va taqqoslang.

a) 25 va 4,7      b) -79 va -81      c) -5 va 0      d) 78 va -50

15. Amallarni bajaring va natijani  $\frac{p}{q}$  ko'rinishida yozing.

a)  $1 - \frac{1}{12}$       b)  $-\frac{1}{12} + \frac{2}{3}$       c)  $5\frac{4}{7} + (-4\frac{1}{14})$       d)  $-4,17 + 5,53$

16. Hisoblang.

a)  $2 - 1\frac{19}{319}$       b)  $7 - 2\frac{77}{97}$       c)  $39 - 29\frac{23}{124}$       d)  $2023 - 2\frac{2023}{2024}$

## RATSIONAL SONLARNI QO'SHISH



Eslaymiz!

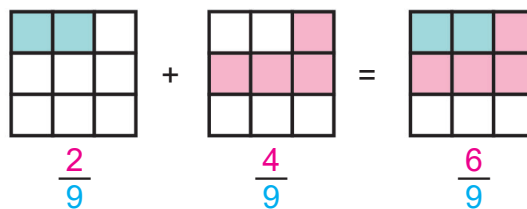
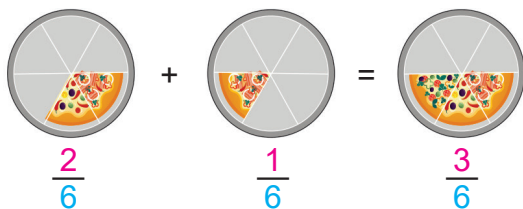

Ixtiyoriy ishorali ratsional sonlar yig'indisi:

$$\frac{k}{n} + \frac{p}{q} = \frac{k \times q + p \times n}{n \times q}$$

$$\frac{2}{3} + \frac{1}{2} = \frac{2 \times 2 + 1 \times 3}{3 \times 2} = \frac{4 + 3}{6} = \frac{7}{6} = 1\frac{1}{6}$$

kasrning xossasiga ko'ra

$$\frac{-5}{12} + \frac{-1}{18} = \frac{-5 \times 3}{12 \times 3} + \frac{-1 \times 2}{18 \times 2} = \frac{-15 + (-2)}{36} = \frac{-17}{36} = -\frac{17}{36}$$



Guruhlarda ishlaymiz: 1-4.

1. Hisoblang, bo'sh kataklarni to'ldiring.

$$a) \frac{-8}{11} + \frac{-2}{11} = \frac{-8 + (-2)}{\square} = \frac{\square}{\square}$$

$$b) \frac{11}{19} + \frac{-3}{19} = \frac{\square + \square}{\square} = \frac{\square}{\square}$$

$$c) 14,7 + 5,27 = \frac{\square}{10} + \frac{527}{100} = \frac{1470}{\square} + \frac{\square}{\square} = \frac{\square + \square}{\square} = \frac{\square}{\square} = 19,97$$

2. Toping.

$$a) -\frac{4}{5} \text{ dan } \frac{4}{5} \text{ ga katta bo'lgan sonni}$$

$$b) \frac{2}{3} \text{ dan } \frac{1}{3} \text{ ga katta bo'lgan sonni}$$

3. Hisoblang.

$$a) \left(\frac{7}{8} + \frac{9}{11} + \frac{15}{17}\right) + \left(\frac{1}{8} + \frac{2}{11} + \frac{2}{17}\right) \quad b) \left(1\frac{5}{9} + 2\frac{7}{13} + 3\frac{11}{19}\right) + \left(3\frac{4}{9} + 2\frac{6}{13} + 1\frac{8}{19}\right)$$

4. Birinchi kuni ishning  $\frac{3}{8}$  qismi, ikkinchi kuni esa  $\frac{1}{6}$  qismi bajarildi. Shu ikki kunda ishning qancha qismi bajarilgan?



### Mustahkamlash: 5–10.

5. Hisoblang.

a)  $\frac{5}{9} + (-\frac{7}{9})$

b)  $\frac{-10}{19} + \frac{5}{19}$

c)  $\frac{-12}{23} + (-\frac{11}{23})$

d)  $\frac{16}{37} + \frac{11}{37}$

6. Bir shaxmat o'yini  $\frac{11}{12}$  soat, ikkinchisi esa  $\frac{5}{6}$  soat davom etdi. Bu musobaqa necha soat davom etgan?

7. Hisoblang.

a)  $12,7 + 111,5$

b)  $0,25 + 12,1$

c)  $-121,12 + 41,4$

d)  $0,(5) + 1,(5)$

e)  $1,1 + (-2,44)$

f)  $12,101 + (-2,1)$

g)  $-45,7 + (-51,22)$

h)  $2,(4) + 3,(6)$

8. Jadvalda 1950- va 2021-yillardagi dunyo aholisi soni ko'rsatilgan.

a) Yetishmayotgan qiymatlarni yozing.

b) 1950-yildan 2021-yilgacha dunyo aholisi necha millionga oshgan?

Dunyo hududlari	1950-yildagi aholi (mln)	2021-yildagi aholi (mln)	Farqi
Afrika	222	1373,5	
Osiyo	...	4679,6	1317,4
Yevropa	393	...	354,6
Janubiy Amerika	166	448	
Shimoliy Amerika	166	495,2	
Okeaniya	13	43,2	
Dunyo bo'yicha	2518	7687,1	

9. Kunduzi havo harorati  $+3\text{ }^{\circ}\text{C}$  bo'ldi. Kechqurun:

a)  $2\text{ }^{\circ}\text{C}$  ga sovidi;

b)  $5\text{ }^{\circ}\text{C}$  ga sovidi;

c)  $3\text{ }^{\circ}\text{C}$  ga issiqroq bo'ldi;

Haroratning o'zgarishini yig'indi sifatida yozing va uning qiymatini toping.

10. Barcha harorat a)  $12\text{ }^{\circ}\text{C}$  ga; b)  $8\text{ }^{\circ}\text{C}$  ga ko'tarilsa, ko'rsatkichlar qanday o'zgaradi?

a)

b)

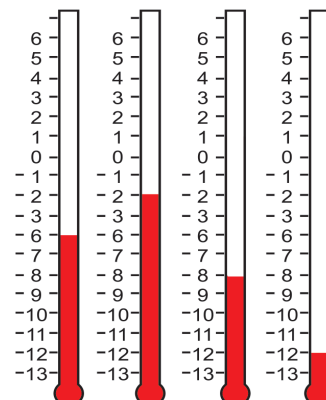
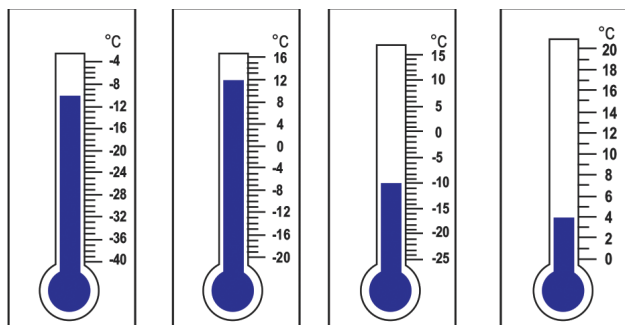



## Mustaqil ish: 11–17.

11. Hisoblang.

a)  $\frac{1}{6} + \frac{1}{4}$

b)  $\frac{3}{10} + \frac{2}{15}$

c)  $\frac{4}{25} + \frac{7}{15}$

d)  $\frac{12}{55} + \frac{14}{33}$

e)  $\frac{-1}{6} + \frac{3}{8}$

f)  $\frac{5}{12} + \frac{-3}{16}$

g)  $\frac{-2}{9} + \frac{1}{-15}$

h)  $\frac{11}{-42} + \frac{4}{35}$

12. Toping.

a)  $\frac{5}{8}$  dan  $\frac{7}{12}$  ga katta bo'lgan sonni

b)  $\frac{9}{13}$  dan  $\frac{11}{26}$  ga katta bo'lgan sonni

13. Son o'qidan foydalanib ifoda tuzing va hisoblang.

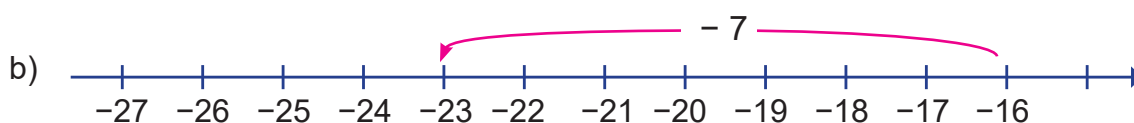
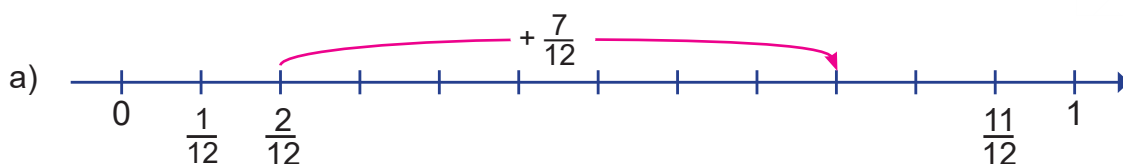

14. Hisoblang.

a)  $\frac{1}{2} + \frac{1}{4} + \frac{3}{8}$

b)  $\frac{3}{4} + \frac{5}{6} + \frac{1}{2}$

c)  $\frac{4}{5} + \frac{4}{15} + \frac{3}{10}$

d)  $\frac{3}{8} + \frac{5}{6} + \frac{7}{12}$

15. Uchburchakning bir tomoni 3,1 m, ikkinchi tomoni 2,89 m va uchinchi tomoni 3,01 m bo'lsa, uning perimetrini toping.

16. Bo'sh kataklarni to'ldiring.

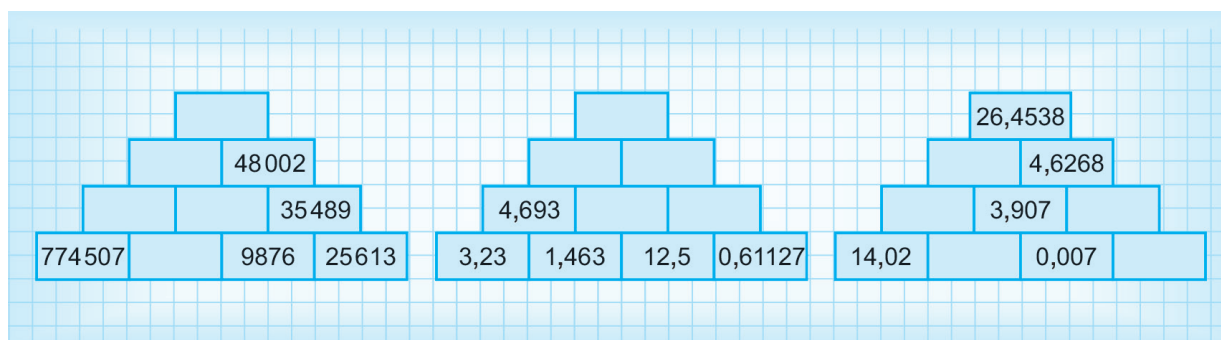
17. Yo'lovchi dastlab  $\frac{2}{3}$  soat, keyin esa  $\frac{1}{2}$  soat yo'l yurdi. U jami necha soat yo'l bosgan?

## RATSIONAL SONLARNI AYIRISH



Eslaymiz!

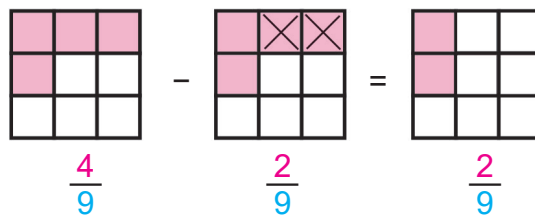
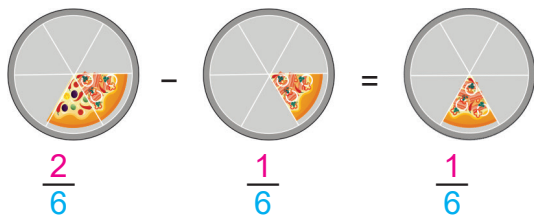

Ixtiyoriy ishoralari ratsional sonlar ayirmasi:

$$\frac{k}{n} - \frac{p}{q} = \frac{k \times q - p \times n}{n \times q}$$

$$\frac{2}{3} - \frac{1}{2} = \frac{2 \times 2 - 1 \times 3}{3 \times 2} = \frac{4 - 3}{6} = \frac{1}{6}$$

$$\frac{-5}{12} - \frac{-1}{18} = \frac{-5 \times 3}{12 \times 3} - \frac{-1 \times 2}{18 \times 2} = \frac{-15 - (-2)}{36} = \frac{-13}{36}$$

kasming xossasiga ko'ra



Guruhlarda ishlaymiz: 1–3.

1. Hisoblang, bo'sh kataklarni to'ldiring.

$$\text{a) } \frac{-2}{15} - \frac{-7}{15} = \frac{-2 + 7}{\square} = \frac{\square}{\square} = \frac{\square}{\square} \quad \text{b) } \frac{-5}{16} - \frac{1}{16} = \frac{-5 + (-1)}{\square} = \frac{\square}{\square} = \frac{\square}{\square}$$

$$\text{c) } \frac{17}{36} - \frac{-11}{9} = \frac{17}{\square} + \frac{\square \times 4}{\square \times 4} = \frac{\square + \square}{\square} = \frac{\square}{\square} = \frac{\square}{\square}$$

$$\text{d) } \frac{-5}{14} - \frac{-4}{35} = \frac{-5 \times \square}{14 \times \square} - \frac{-4 \times \square}{35 \times \square} = \frac{\square}{70} - \frac{-8}{\square} = \frac{\square + \square}{\square} = \frac{\square}{\square}$$

2. Toping.

$$\text{a) } -\frac{4}{5} \text{ dan } \frac{4}{5} \text{ ga kichik bo'lgan sonni} \quad \text{b) } \frac{2}{3} \text{ dan } \frac{1}{3} \text{ ga kichik bo'lgan sonni}$$

$$\text{c) } 1,8 \text{ dan } 3,4 \text{ ga kichik bo'lgan sonni} \quad \text{d) } -4,7 \text{ dan } 5,1 \text{ ga kichik bo'lgan sonni}$$

3. Chelakka suv quyilganidan keyin uning massasi 6,25 kg ga teng bo'ldi. Agar bo'sh chelak 1,75 kg bo'lsa, unga quyilgan suv massasini aniqlang.



### Mustahkamlash: 4-7.

4. Hisoblang.

a)  $3\frac{1}{3} - 3\frac{2}{3}$

b)  $5\frac{7}{8} - 5\frac{5}{8}$

c)  $13\frac{15}{42} - 12\frac{5}{42}$

d)  $16\frac{6}{11} - 14\frac{2}{11}$

e)  $2\frac{3}{5} - 1\frac{1}{10}$

f)  $20\frac{4}{15} - 9\frac{3}{20}$

g)  $-5\frac{10}{35} - 6\frac{5}{14}$

h)  $5\frac{11}{42} - 1\frac{1}{2}$

5. Jadvalni to'ldiring.

$a$	$b$	$a + b$	$a - b$	$ a + b $	$ a - b $	$ a  -  b $	$ b  -  a $
$-7\frac{7}{10}$	20						
18	-2,3						
-2,9	-47						
-3,4	7,5						
6,5	-4,9						

6. Men o'ylagan sonimga 7,(3) ni qo'shganimda 9,(23) hosil bo'ldi. Ayting-chi, men qaysi sonni o'yladim?

7. Ayirmani toping.

a)  $-\frac{1}{2} - \frac{1}{3}$

b)  $\frac{11}{18} - \frac{13}{24}$

c)  $\frac{22}{35} - \frac{-3}{14}$

d)  $\frac{32}{64} - \frac{9}{27}$



### Mustaqil ish: 8-11.

8. Hisoblang.

a)  $1 - \frac{3}{4}$

b)  $5 - \frac{5}{8}$

c)  $7 - \frac{9}{23}$

d)  $11 - \frac{18}{37}$

9. Mevaning idish bilan birgalikdagi massasi  $4\frac{4}{5}$  kg. Idish massasi  $1\frac{1}{5}$  kg bo'lsa, unda qancha meva bor?

10. Toping.

a)  $\frac{5}{8}$  dan  $\frac{7}{12}$  ga kichik bo'lgan sonni

b)  $\frac{9}{13}$  dan  $\frac{11}{26}$  ga kichik bo'lgan sonni

11. Ayirmani hisoblang.

a)  $27\frac{9}{10} - 17\frac{4}{15}$

b)  $11\frac{2}{3} - 7\frac{1}{6}$

c)  $25\frac{3}{11} - 4\frac{5}{22}$

d)  $15\frac{23}{24} - 10\frac{7}{12}$

## RATSIONAL SONLARNI KO'PAYTIRISH



Eslaymiz!

$$\frac{3}{4} \times \frac{1}{2} = \frac{3 \times 1}{4 \times 2} = \frac{3}{8}$$

$$\frac{5}{7} \times \frac{2}{10} = \frac{\overset{1}{\cancel{5}} \times 2}{7 \times \underset{2}{\cancel{10}}} = \frac{2}{14} = \frac{1}{7}$$



Ixtiyoriy ishorali ratsional sonlar ko'paytmasini topish kasrlar va butun sonlarni ko'paytirish qoidasi kabi bajariladi.

$$\frac{k}{n} \times \frac{p}{q} = \frac{k \times p}{n \times q}$$

Noldan farqli, *bir xil ishorali* ratsional sonlar ko'paytmasi *musbat*, *har xil ishorali* ratsional sonlar ko'paytmasi esa *manfiy* son bo'ladi.

$$-\frac{9}{16} \times \left(-\frac{2}{3}\right) = \frac{(-9) \times (-2)}{16 \times 3} = \frac{\overset{3}{\cancel{9}} \times \overset{1}{\cancel{2}}}{\underset{8}{16} \times \underset{3}{3}} = \frac{3}{8}$$

$$\frac{2}{3} \times \left(-\frac{5}{7}\right) = \frac{2 \times (-5)}{3 \times 7} = \frac{-10}{21}$$



Guruhlarda ishlaymiz: 1–4.

1. Ko'paytmalarni toping.

a)  $-\frac{3}{4} \times \frac{5}{7}$

b)  $-\frac{2}{5} \times \frac{7}{11}$

c)  $\frac{1}{8} \times \left(-\frac{3}{4}\right)$

d)  $1,5 \times \left(-\frac{2}{15}\right)$

e)  $-5,2 \times \left(-\frac{5}{104}\right)$

f)  $\frac{11}{16} \times (-0,5)$

2. Ifodaning qiymatini toping.

a)  $\frac{1}{4} \times a$ ; agar  $a = \frac{4}{5}$ ;  $a = 1\frac{1}{3}$

b)  $2,5 \times b$ ; agar  $b = 3\frac{1}{3}$ ;  $b = 4\frac{2}{7}$

3. To'g'ri to'rtburchakning bo'yi  $2\frac{3}{4}$  cm, eni undan  $1\frac{2}{3}$  cm uzun bo'lsa, uning yuzini hisoblang.

4. Qulay usullarda hisoblang.

a)  $15\frac{5}{7} \times \frac{3}{4} + 12\frac{2}{7} \times \frac{3}{4}$

b)  $-14\frac{7}{9} \times 16 + 18\frac{7}{9} \times 16$

c)  $7\frac{5}{11} \times 15 + 5\frac{6}{11} \times 15$

d)  $131\frac{4}{11} \times 91 - 31\frac{4}{11} \times 91$





### Mustahkamlash: 5–10.

5. Hisoblang.

a)  $\frac{3}{8} \times 24$

b)  $\frac{4}{5} \times 40$

c)  $\frac{3}{9} \times 27$

d)  $15 \times \frac{5}{6}$

e)  $12 \times \frac{2}{3}$

f)  $45 \times \frac{5}{9}$

6. Ko'paytirishlarni bajaring.

a)  $\frac{1}{2} \times (-\frac{4}{9})$

b)  $-\frac{14}{17} \times \frac{34}{63}$

c)  $(-\frac{4}{7}) \times (-\frac{5}{6})$

d)  $-1 \frac{1}{3} \times 2 \frac{1}{2}$

e)  $3 \frac{5}{6} \times (-4 \frac{4}{5})$

f)  $-5 \frac{1}{6} \times (-1 \frac{1}{31})$

7. Go'zlarning og'irligi qanchadan?

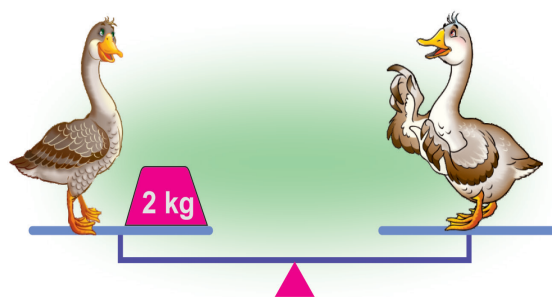
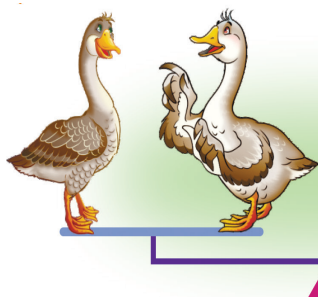

8. Tomonlari uzunliklari  $5 \frac{1}{3}$  dm va  $6 \frac{3}{4}$  dm bo'lgan to'g'ri to'rtburchakning yuzini toping.

9. Jadvalni to'ldiring.

$a$	$-2 \frac{5}{7}$	$3 \frac{1}{3}$	$-4 \frac{2}{3}$	$7 \frac{1}{2}$	-0,12	5,1
$b$	$1 \frac{1}{19}$	$-2 \frac{1}{10}$	$-2 \frac{3}{4}$	$8 \frac{2}{3}$	2,5	-3,2
$a \times b$						

10. Ko'paytmani hisoblang.

a)  $\frac{2}{3} \times \frac{4}{5}$

b)  $\frac{9}{10} \times \frac{5}{12}$

c)  $\frac{5}{6} \times \frac{2}{3}$

d)  $\frac{3}{8} \times \frac{4}{9}$

e)  $\frac{3}{4} \times \frac{5}{7}$

f)  $\frac{2}{5} \times \frac{7}{11}$

Esda saqlang!

$\frac{k}{n}$	$\frac{p}{q}$	$\frac{k}{n} \times \frac{p}{q}$
+	+	+
+	-	-
-	+	-
-	-	+



## Mustaqil ish: 11-14.

11. Hisoblang.

a)  $21 \times (\frac{2}{7} + \frac{5}{21})$     b)  $(\frac{3}{8} + \frac{5}{12}) \times 24$     c)  $(4\frac{2}{3} + 5\frac{1}{2}) \times 6$     d)  $7 \times (3\frac{2}{7} + \frac{5}{7})$

12. Ifodaning qiymatini toping.

a)  $(8 - \frac{2}{5}) \times 1\frac{1}{4}$     b)  $(3\frac{1}{3} - \frac{1}{9}) \times 3$     c)  $(9 - \frac{3}{4}) \times 1\frac{1}{3}$     d)  $(2\frac{1}{5} - \frac{1}{15}) \times 15$

13. Qulay usulda hisoblang.

a)  $37 \times 112\frac{2}{3} - 37 \times 12\frac{2}{3}$     b)  $124 \times 9\frac{3}{4} - 124 \times 4\frac{3}{4}$

c)  $45 \times 21\frac{5}{6} - 45 \times 12\frac{5}{6}$     d)  $31 \times 21\frac{4}{5} - 31 \times 10\frac{4}{5}$

14. Keyingi shaklni toping.

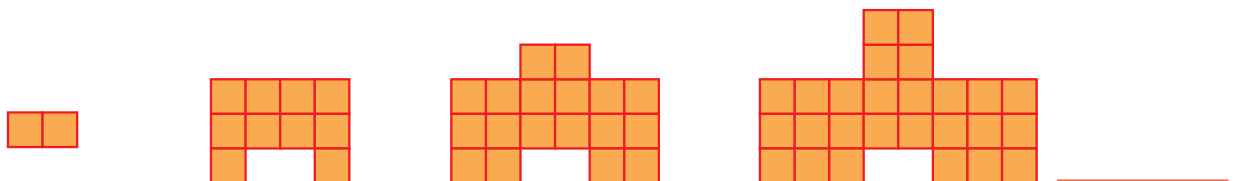
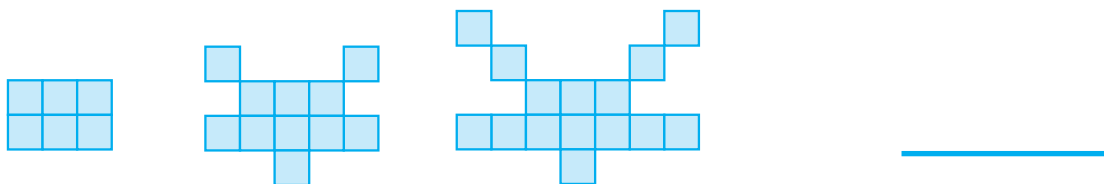

## RATSIONAL SONLARNI BO'LISH



Eslaymiz!

$$\frac{5}{12} \div \frac{7}{24} = \frac{5}{12} \times \frac{24}{7} = \frac{5 \times 2}{1 \times 7} = \frac{10}{7} = 1 \frac{3}{7}$$

$$\frac{1}{4} \div \frac{5}{4} = \frac{1}{4} \times \frac{4}{5} = \frac{1}{5}$$



Ixtiyoriy ishorali ratsional sonlar bo'linmasini topish kasrlar va butun sonlarni bo'lish qoidasi kabi bajariladi.

$$\frac{k}{n} \div \frac{p}{q} = \frac{k \times q}{n \times p} \quad n \neq 0 \quad p \neq 0$$

Noldan farqli, **bir xil ishorali** ratsional sonlar bo'linmasi **musbat**, **har xil ishorali** ratsional sonlar bo'linmasi **manfiy** son bo'ladi.

$$-\frac{4}{15} \div \left(-\frac{2}{3}\right) = \frac{(-4)}{15} \times \frac{(-3)}{2} = \frac{4}{15} \times \frac{3}{2} = \frac{2}{5}$$

$$\frac{2}{3} \div \left(-\frac{5}{7}\right) = \frac{2 \times (-7)}{3 \times 5} = \frac{-14}{15}$$



Guruhlarda ishlaymiz: 1-4.

1. Bo'linmani toping.

a)  $\frac{2}{5} \div \frac{3}{7}$

b)  $-\frac{1}{8} \div \frac{1}{4}$

c)  $\frac{1}{2} \div \frac{4}{5}$

d)  $\frac{11}{18} \div \left(-\frac{5}{9}\right)$

2. Hisoblang.

a)  $6 \div \frac{1}{4}$

b)  $5 \div \frac{5}{6}$

c)  $-10 \div \frac{5}{9}$

d)  $-15 \div \left(-\frac{3}{5}\right)$

e)  $-13 \div \left(-2\frac{4}{11}\right)$

f)  $-1 \div \frac{1}{15}$

g)  $2 \div \left(-\frac{6}{7}\right)$

h)  $-\frac{7}{8} \div 3$

3. Bo'lishni bajaring.

Namuna:  $9 \div 0,004 = 9 \div \frac{4}{1000} = 9 \times \frac{1000}{4} = 9 \times 2500 = 22500$

a)  $351,9 \div (-17)$

b)  $-62,558 \div 62$

c)  $-1617,84 \div (-321)$

4. Hisoblang.

a)  $3\frac{1}{2} \div (-2\frac{1}{3})$

b)  $-2\frac{5}{8} \div 1\frac{3}{4}$

c)  $-5\frac{1}{9} \div (-7\frac{2}{3})$

d)  $10\frac{4}{5} \div 3\frac{3}{5}$



**Mustahkamlash: 5-9.**

5. Hisoblang.

a)  $-7\frac{1}{2} \times 12\frac{1}{4} \div \frac{49}{8}$

b)  $-\frac{5}{7} \div (-\frac{15}{14}) \times \frac{3}{8}$

c)  $-\frac{8}{9} \div (-\frac{16}{5}) \div (-\frac{55}{27})$

d)  $\frac{10}{21} \div \frac{20}{7} \div (-\frac{50}{3})$

6. Bo'lishni bajaring.

a)  $-1 \div \frac{1}{5}$

b)  $1 \div (-\frac{7}{10})$

c)  $-\frac{4}{5} \div (-5)$

d)  $\frac{7}{10} \div (-4)$

7. Bo'lishni bajaring.

a)  $\frac{5}{6} \div (-1\frac{2}{3})$

b)  $-3\frac{1}{7} \div \frac{4}{7}$

c)  $-\frac{15}{38} \div (-1\frac{1}{19})$

d)  $12\frac{1}{2} \div 5$

8. Amallarni bajaring.

a)  $\frac{2}{3} \div \frac{8}{9} \div \frac{15}{28}$

b)  $\frac{10}{21} \div \frac{20}{7} \div (-\frac{5}{3})$

c)  $-\frac{2}{3} \div \frac{25}{7} \div (-\frac{15}{18})$

9. O'nli kasrni oddiy kasrda ifodalab bo'lishni bajaring.

a)  $-2,7 \div 9$

b)  $6,25 \div (-25)$

c)  $-4,8 \div (-80)$

**Esda saqlang!**

$\frac{k}{n}$	$\frac{p}{q}$	$\frac{k}{n} \div \frac{p}{q}$
+	+	+
-	+	-
+	-	-
-	-	+



### Mustaqil ish: 10–12.

10. Bo'lishni bajaring.

$$\text{a) } -\frac{5}{12} \div 2 \quad \text{b) } -5 \div \frac{2}{3} \quad \text{c) } -4 \div \left(-\frac{3}{5}\right) \quad \text{d) } 6 \div \left(-\frac{3}{7}\right)$$

11. Bo'linmani toping.

$$\begin{array}{llll} \text{a) } 5 \div (-0,5) & \text{b) } -\frac{18}{5} \div 0,9 & \text{c) } 52 \div \left(-\frac{13}{100}\right) & \text{d) } 41,7 \div \left(-\frac{1}{10}\right) \\ \text{e) } -8 \div \left(-\frac{4}{5}\right) & \text{f) } \frac{9}{2} \div (-5) & \text{g) } -0,36 \div \frac{3}{25} & \text{h) } 0,003 \div \left(-\frac{1}{100}\right) \end{array}$$

12. Bo'lishni bajaring.

$$\begin{array}{lll} \text{a) } 12,4 \div \frac{31}{1000} & \text{b) } 21,875 \div \left(-3\frac{1}{8}\right) & \text{c) } 11\frac{1}{2} \div (-2,3) \\ \text{d) } 2,7856 \div \left(-\frac{8}{25}\right) & \text{e) } -3\frac{3}{5} \div \left(-\frac{9}{100}\right) & \text{f) } 0,012 \div \frac{1}{50} \end{array}$$

## RATSIONAL SONLAR USTIDA AMALLARGA DOIR TOPSHIRIQLAR



Har qanday ratsional sonlar uchun quyidagi xossalar o'rinlidir.

Qo'shishning o'rin almashinish xossasi:

$$a + b = b + a$$

Qo'shishning guruhlash xossasi:

$$(a + b) + c = a + (b + c)$$

Ratsional songa nol qo'shilishi bu sonni o'zgartirmaydi:

$$a + 0 = a$$

Ratsional sonning qarama-qarshi soni bilan yig'indisi nolga teng:

$$a + (-a) = 0$$

Ko'paytirishning qo'shishga nisbatan taqsimot xossasi:

$$a \times (b + c) = a \times b + a \times c$$

Ko'paytirishning o'rin almashinish xossasi:

$$ab = ba$$

Ko'paytirishning guruhlash xossasi:

$$(a \times b) \times c = a \times (b \times c)$$

Ratsional son 1 ga ko'paytirilganda bu son o'zgarmaydi:

$$a \times 1 = a$$

Ratsional songa o'zaro teskari ratsional sonning ko'paytmasi 1 ga teng:

$$a \times \frac{1}{a} = 1$$



### Guruhlarda ishlaymiz: 1–4.

1. Hisoblashlarni tahlil qilib, xulosalang.

$$\text{a) } \frac{5}{7} \times \frac{2}{10} = \frac{5 \times 2}{7 \times 10} = \frac{10}{70} = \frac{1}{7} \text{ yoki } \frac{2}{10} \times \frac{5}{7} = \frac{2 \times 5}{10 \times 7} = \frac{10}{70} = \frac{1}{7}$$

$$b) \frac{2}{3} \times \left(-\frac{5}{7} \times \frac{3}{4}\right) = \frac{2}{3} \times \left(\frac{(-5) \times 3}{7 \times 4}\right) = \frac{2}{3} \times \frac{-15}{28} = \frac{-30}{84} = -\frac{5}{14}$$

$$c) -\frac{2}{5} \times \left(2\frac{1}{7} + \left(-\frac{5}{14}\right)\right) = -\frac{2}{5} \times 2\frac{1}{7} + \left(-\frac{2}{5}\right) \times \left(-\frac{5}{14}\right) = -\frac{2}{5} \times \frac{15}{7} + \frac{2}{5} \times \frac{5}{14} =$$

$$= -\frac{6}{7} + \frac{1}{7} = \frac{-6+1}{7} = -\frac{5}{7}$$

2. Bir traktorchi ekin maydonini 10 kunda, ikkinchi traktorchi shu maydonni 12 kunda, uchinchi traktorchi esa 15 kunda shudgor qila oladi. Agar uchala traktorchi birga ishlasa, bu maydonni necha kunda shudgorlaydi?

3. To'g'ri to'rtburchakning perimetri 74 cm ga teng. Bo'yi enidan 1,4 cm uzun. Shu to'g'ri to'rtburchakning bo'yi va enini toping.

4. Amallar tartibini aniqlab, ifodaning qiymatini toping.

$$a) -12,3 + 8,5 - 1,9$$

$$b) -0,636 \div 0,6 + 0,6 \times 0,1$$

$$c) 0,6 \times \frac{5}{6} + \left(2\frac{2}{15} - 3\frac{5}{9}\right) \div 9,6$$

$$d) \left(-1\frac{2}{3} + \left(-1\frac{1}{3}\right)\right) \div \left(-\frac{3}{11}\right)$$



#### Qiziqarli matematika: 5-6.

5. Ikkita sonning yig'indisi 140 ga teng. Birinchi sonning  $\frac{1}{4}$  qismi ikkinchi sonning  $\frac{1}{3}$  qismiga teng. Shu sonlarni toping.

6. Bir nechta bola pul to'plab futbol to'pi sotib olmoqchi. Agar har bir bola 500 so'mdan bersa, to'p olish uchun yana 500 so'm yetmaydi. Agar har bir bola 800 so'mdan bersa, 1 000 so'm pul ortib qoladi. Bolalar nechta?



#### Mustahkamlash: 7-10.

7. Amallarni bajaring.

$$a) \left(1\frac{3}{4} \times \frac{2}{5} + 3\frac{3}{7} \div \frac{9}{14}\right) \div \frac{5}{12} - 10\frac{1}{5}$$

$$b) \frac{3}{5} \div \frac{9}{10} + 3\frac{3}{4} \times \frac{2}{5} - 4 \div 2\frac{2}{3}$$

$$c) 1\frac{7}{15} \times 1\frac{4}{11} + 2\frac{8}{17} \div 1\frac{1}{34} - \frac{1}{2} \div \left(1\frac{2}{3} - 1\frac{1}{6}\right)$$

$$d) 8\frac{1}{7} \div 1\frac{5}{14} + 11 \div \left(2\frac{3}{4} - 1\frac{3}{8}\right) - 3 \times \left(1\frac{4}{5} + 1\frac{1}{5}\right)$$

8\*. To'g'ri to'rtburchakning bo'yi 2,4 cm ga kamaytirildi, eni esa 1,3 marta orttirildi. Natijada yangi to'g'ri to'rtburchakning yuzi avvalgisiga qaraganda 1,04 marta orttirildi. Yangi to'g'ri to'rtburchakning bo'yini toping.

9. Hisoblang.

$$a) 12 \frac{5}{6} + 2 \frac{7}{9} \times (15 \frac{9}{10} - 12 \frac{9}{10})$$

$$b) 13 \frac{3}{8} + 4 \frac{5}{7} \times (19 \frac{3}{17} - 5 \frac{3}{17})$$

$$c) 3 \frac{4}{17} \times 5 \frac{2}{3} + 3 \frac{4}{17} \times 11 \frac{1}{3}$$

$$d) 5 \frac{7}{16} \times 1 \frac{3}{29} + 2 \frac{5}{16} \times 2 \frac{2}{7}$$

$$e) 1 \frac{5}{12} \times \frac{3}{34} + 1 \frac{5}{12} \times 1 \frac{31}{34}$$

$$f) 10 \frac{2}{3} \div 2 \frac{2}{15} - 2 \frac{2}{5} \times 2 \frac{1}{2}$$

10. Ikki sonning ayirmasi 2,4 ga teng. Ularning biri ikkinchisidan 2,5 marta katta. Shu sonlarni toping.



### Mustaqil ish: 11–15.

11. Sonli ifodaning qiymatini toping.

$$a) 4 \div (5 \frac{1}{3} + 2 \frac{2}{3})$$

$$b) (-8 \frac{1}{12} + 6 \frac{1}{4}) \times 3$$

$$c) \frac{3}{7} \times (-4 \frac{2}{3}) \div (-\frac{1}{2})$$

$$d) (3 \frac{2}{3} - 1 \frac{2}{7} \times 5 \frac{4}{9}) \div (-2,5)$$

$$e) -16,2 + 9,5 - 3,4$$

$$f) -7,14 \div 0,7 + 120 \times 0,01$$

12. O'quvchi bir son o'yladi. Agar uni 12 ga ko'paytirib, ko'paytmaga 69 qo'shilsa va hosil bo'lgan yig'indi 9 ga bo'linsa, u holda bo'linma 41 ga teng bo'ladi. O'quvchi qanday son o'ylagan?

13. Hisoblang.

$$a) 4 \div (5 \frac{1}{3} + 2 \frac{2}{3})$$

$$b) (-\frac{1}{12} + 6 \frac{1}{4}) \times 3$$

$$c) 6 \times (7 \frac{4}{9} - 8 \frac{5}{18})$$

$$d) -\frac{1}{4} \times (-1 \frac{1}{15}) \div (-4)$$

14. Bir tokchada ikkinchisiga qaraganda 3 marta ko'p kitob bor. Ikkala tokchadagi jami kitoblar soni 108 ta bo'lsa, har bir tokchada nechtdan kitob bor?

15. Oralaridagi masofa 38 km bo'lgan ikki velosipedchi bir-biriga qarab yo'lga chiqdi. Birinchi velosipedchining tezligi 13 km/h, ikkinchisniki esa 12 km/h. Necha soatdan so'ng ular orasidagi masofa 13 km bo'ladi?

## PISA TOPSHIRIG'I ASOSIDA BILIMINGIZNI SINAB KO'RING

1. Futbol bo'yicha O'zbekiston o'smirlar jamoasi murabbiysi hujum chizig'ini kuchaytirish maqsadida bir hujumchi va ikkita yarim himoyachini saralash asosida qabul qilish uchun ochiq tanlov e'lon qildi. Talab etilgan ko'rsatkichlar asosida nomzodlar jadvali taqdim etildi.

Futbolchilarning ismi	Gollar soni	O'yinlar soni	Assistlar soni (Golli uzatma)
Eldor	25	30	12
Jasur	19	22	6
Jaloliddin	23	23	11
Ibrohim	21	28	10
Otabek	24	27	12
Aziz	26	35	13
Igor	25	28	11

*Izoh: hujumchi o'yinga nisbatan gollar soniga qarab tanlanadi. Yarim himoyachi esa assistlar (golli uzatma) soniga qarab tanlanadi.*

Savol. Murabbiy hujumchi va yarim himoyachi sifatida kimlarni tanlaydi?

2. Shahar sharoitida harakatlanishning eng qulay vositasi sifatida avtobusdan foydalaniladi. Samarqand shahridagi 64-avtobus bitta reys davomida 50 ta bekatda to'xtab, 24,84 km masofani bosib o'tadi. Avtobusning bir o'rtacha qatnov vaqti (borib-kelishi) 70 minut bo'lib, u har bekatda o'rtacha 0,5 minut to'xtashishi mumkin.



1-savol. Yo'nalish davomida avtobus o'rtacha qanday tezlik bilan harakatlanadi?

2-savol. Agar shaharda 12 ta 64-sonli avtobus harakati yo'lga qo'yilgan bo'lsa, taqriban (javobni yaxlitlang) har necha minutda keyingi avtobus keladi?



## LOYIHA ISHI

### Avtokredit

O'zbekiston banklaridan ixtiyoriy 3 tasini tanlang. Internet brauzer sizga tanlash imkoniyatini beradi. Tanlangan 3 ta bankning kredit siyosatini o'rganing. Bizga faqat avtokreditni o'rgansangiz yetarli.

Banklar sizga kredit foizlarini turlicha taklif qiladi. Bank tomonidan berilgan foiz stavkasi qancha past bo'lsa, kredit olganingizda shuncha yaxshi jamg'arma olishingiz mumkin. Ba'zi banklar ko'p foyda olish uchun yuqori foiz stavkasini taklif qiladi va iqtisodiy omillar tufayli foizlarni oldindan ogohlantirmasdan o'zgartiradi.

### Topshiriq

Otangiz mashina olish uchun bankdan 60 mln so'm qarz olmoqchi. Agar otangiz 1 yil, 2 yil, 3 yil va 4 yilga bo'lib-bo'lib to'lashni tanlasa, kamida ikkita usuldan foydalanib mashina uchun to'lanadigan qiymatlarni toping. Ishingizni aniq ko'rsating va natijalaringizni jadvalda ifodalang. Siz 3 ta bankning kredit takliflari hisob-kitobini amalga oshirishingiz kerak. Otangizga qaysi bankni tavsiya qilasiz?

_____ BANK			
Davomiyligi	Yillik foiz stavka	Yillik foiz summasi	Jami qaytariladigan summa
1 yil (12 oy)			
2 yil (24 oy)			
3 yil (36 oy)			
4 yil (48 oy)			

### Sizga yordam beruvchi saytlar:

1. <https://cbu.uz/oz/>
2. <https://cbu.uz/oz/credit-organizations/banks/>
3. <https://bank.uz/credits>

# VI bob

## GEOMETRIYA VA O'LCASHLAR

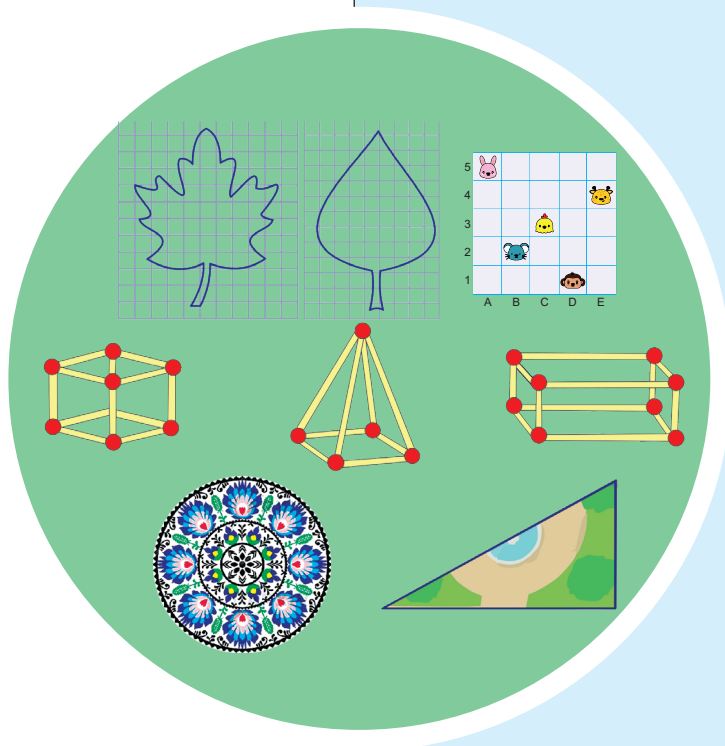

## DEKART KOORDINATALAR SISTEMASI



## Eslaymiz!

Hayvonchalarning koordinata burchagida joylashgan o'rnini toping.

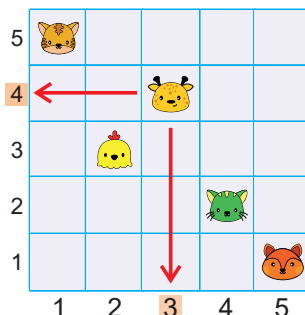
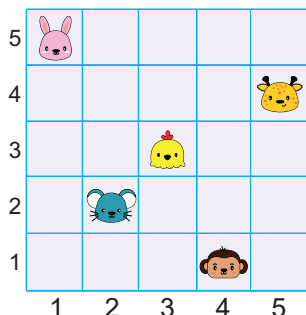

Koordinatalar sistemasi ikkita sonlar o'qining kesishmasidan hosil qilinadi.

$x$  – gorizontalar sonlar o'qi.

$y$  – vertikal sonlar o'qi.

$x$  va  $y$  o'qlar kesishgan nuqta **koordinata boshi** deyiladi va bu nuqtada ikkala o'q uchun ham 0 soni joylashadi.

Koordinatalar sistemasi tekislikni to'rtta qismga ajratadi va ular **choraklar** deyiladi.

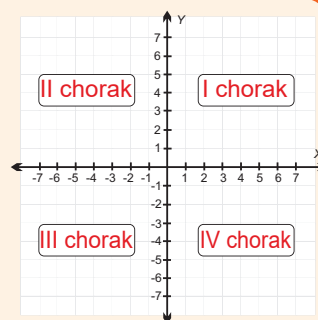
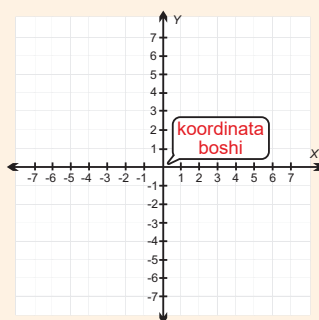

## Guruhlarda ishlaymiz: 1–2.

1. Koordinatalar sistemasida  $(4; 2)$  nuqtani belgilang.

*Bajarish.* Dastlab koordinata boshini aniqlang. Berilgan  $(4; 2)$  nuqtaning  $x$  koordinatasi 4,  $y$  – koordinatasi 2.

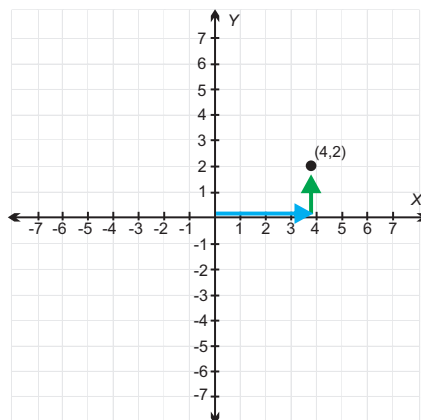
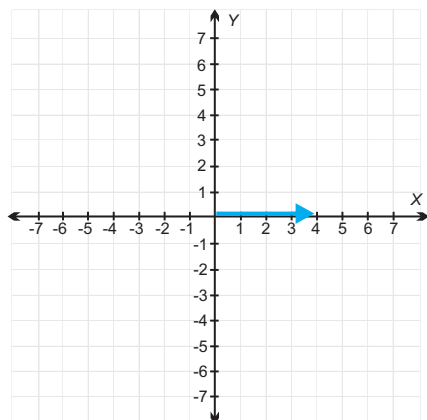

**Rene Dekart** (1596–1650) – fransuz faylasufi, matematigi, fizigi, fiziologi. Koordinatalar sistemasi tushunchasini fanga kiritgani uchun bu sistema uning sharafiga **Dekart koordinatalar sistemasi** deb ataladi.

2. Dekart koordinatalar sistemasida  $(-5; -3)$  nuqtani belgilang.  
*Bajarish.* Dastlab koordinata boshini aniqlang. Berilgan  $(-5; -3)$  nuqtaning  $x$  koordinatasi  $-5$ ,  $y$  koordinatasi  $-3$ .

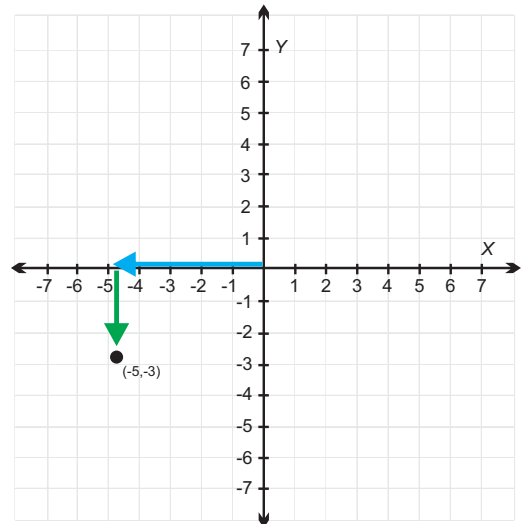
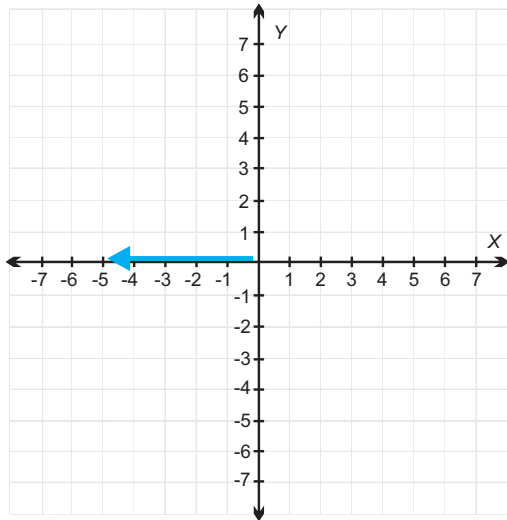

### Mustahkamlash: 3–10.

3. Dekart koordinatalar sistemasida berilgan nuqtalar o'rnini belgilang.

a)  $(2; 5)$       b)  $(4; 6)$       c)  $(-3; 5)$       d)  $(-4; -5)$       e)  $(3; -4)$   
 f)  $(5; 0)$       g)  $(0; 4)$       h)  $(-7; 0)$       i)  $(0; -4)$       l)  $(0; 0)$

4. Ranglar bilan belgilangan nuqtalarning koordinatalarini aniqlang.

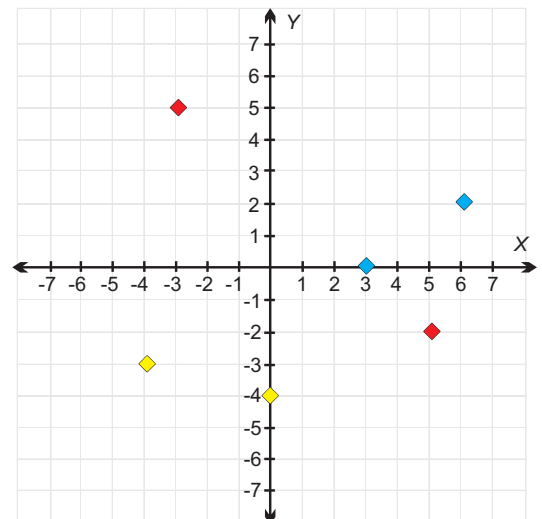

5. Koordinata sistemasida amaliy ish bajaring.

a) Koordinata boshidan chap tomonga uch birlik, yuqoriga to'rt birlik yuring.  
 b) Koordinata boshidan o'ng tomonga ikki birlik, yuqoriga besh birlik yuring.  
 c) Koordinata boshidan chap tomonga to'rt birlik, pastga uch birlik yuring.  
 d) Koordinata boshidan o'ng tomonga uch birlik, pastga ikki birlik yuring.

6. Berilgan shartlarga mos nuqtalarni Dekart koordinatalar sistemasida belgilang.

a)  $x$  o'qdan bir birlik yuqorida va  $y$  o'qdan uch birlik o'ngda joylashgan.  
 b)  $x$  o'qdan uch birlik yuqorida va  $y$  o'qdan besh birlik masofada.  
 c)  $x$  o'qdan to'rt birlik masofada va  $y$  o'qdan ikki birlik masofada.

7. Nuqtalarni koordinatalar sistemasida belgilang.

A (5; 3)      B (-2; 2)      C (0; 3)      D (1; -4)      E (-2; -3)  
 F (-5; 1)      G (1; 5)      H (1; 5)      I (4; 0)      J (-5; 0)  
 K (-3; -4)      L (-1; 4)      M (1; -2)      N (5; -2)      O (2; 5)

8. Ikkinchi chorakdan  $x$  va  $y$  o'qdan bir xil uzoqlikda bo'lgan to'rtta nuqtani belgilang. *E'tibor bering: aniqlangan nuqtalar bir chiziqda joylashadi.*

9. Koordinatalar sistemasida (2; 1) va (6; 1) nuqtalarni belgilang. Ular orasidan barchasi bir to'g'ri chiziqda bo'lgan nuqtalarning koordinatasini toping.

10. a) Chizmada ko'rsatilgan nuqtalarning koordinatalarini yozing.

b) Koordinata sistemasida nuqtalarni belgilang.

F (-5; -2);      G (3; 4);      H (-3; 0)  
 J (-5; 3);      K (4; -4)

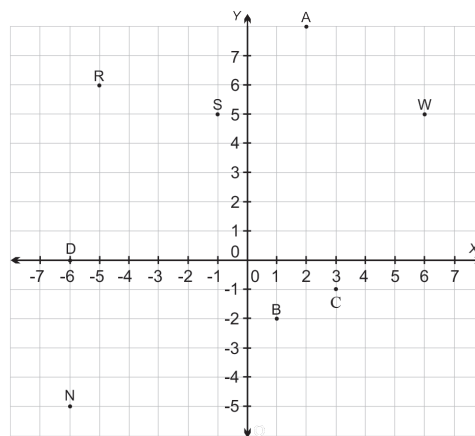

**Mustaqil ish: 11–12.**

11. a) Nuqtalarning koordinatalarini ayting.

b) Nuqtalarning koordinatalarini yozing.

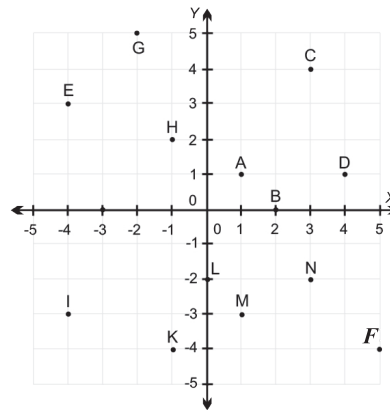
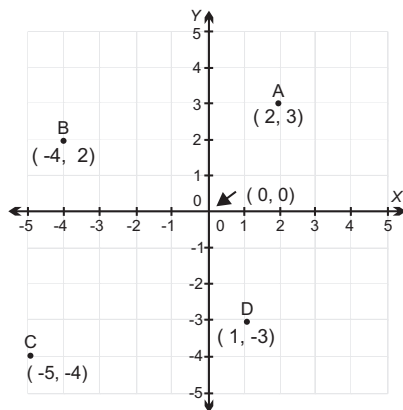

12. Koordinatalarga mos nuqtalarning harflarini toping.

(-6; 0) \_\_\_\_\_

(-5; 6) \_\_\_\_\_

(2; 8) \_\_\_\_\_

(3; -1) \_\_\_\_\_

(1; -2) \_\_\_\_\_

(6; 5) \_\_\_\_\_

(-1; 5) \_\_\_\_\_

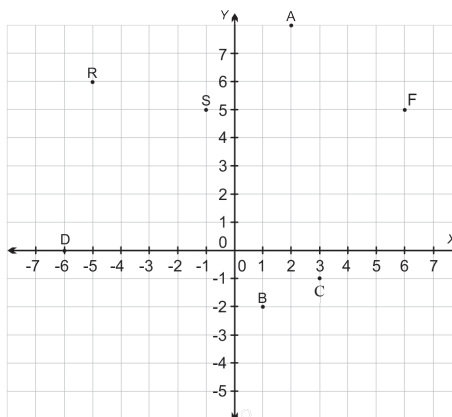

Rasmlar ketma-ketligini tushuntiramiz. Qanday xulosaga keldingiz?

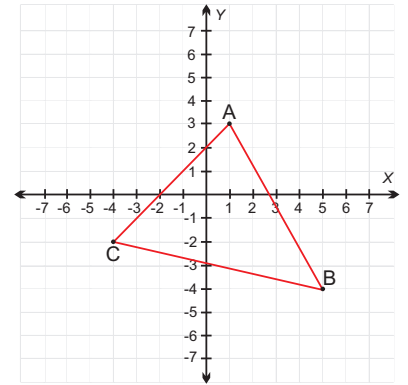
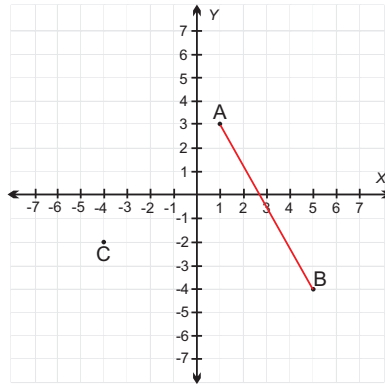
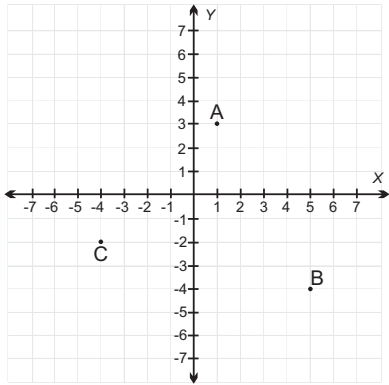

### Guruhlarda ishlaymiz: 1–3.

1. Berilgan nuqtalar yordamida kesmalar yasang.

a) A (–3; 5) va C (0; 0)

b) P (0; –3) va L (3; –5)

c) N (0; 4) va F (0; –4)

d) E (–2; –2) va H (4; –2)

**Eslatma:** AC va CA kesmalar turlicha tartibda nomlanmoqda, lekin bir kesmani anglatadi.

2. A (4; 2), B (2; –3), C (–2; 2) va D (1; –2) nuqtalardan eng ko‘pi bilan nechta turli kesmalar hosil qilish mumkin?

3. Berilgan shaklning uchlari koordinatlarini aniqlang.

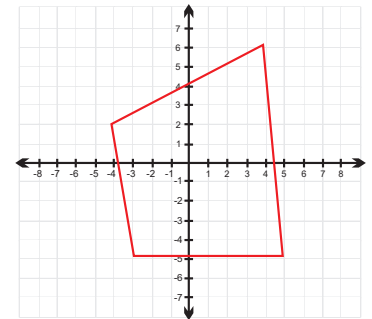

### Mustahkamlash: 4–15.

4. M (0; 5), N (3; –1) va K (–3; –1) nuqtalarni koordinatar sistemasida belgilang va ularni tutashtiring. Qanday shakl hosil bo‘ldi?

5. A (4; 3), B (–2; 3), C (–2; –2) va D (4; –2) nuqtalarni koordinatar sistemasida belgilang va ularni tutashtiring. Qanday shakl hosil bo‘ldi?

6. Quyidagi nuqtalarni koordinatar sistemasida belgilang va ularni ketma-ket birlashtirib shakllar yasang.

a) A (–3; 5), B (3; 5) va C (0; 0)

b) P (0; 0), R (–3; –5) va L (3; –5)

c) K (4; 0), N (0; 4), M (–4; 0) va F (0; –4)

7. A (5; 4), B (1; 4), C (1; –2) nuqtalarni koordinatar sistemasida belgilang.

Shunday D (x; y) nuqtani aniqlaylikki, natijada ABCD to‘g‘ri to‘rtburchak hosil bo‘lsin.

8. A (1; 5), B (2; –4), C (0; –3) va D (–4; –2) nuqtalar bilan barcha mumkin bo‘lgan uchburchaklarni yasang.

9. A (0; 0) va C (5; 3) nuqtalar berilgan. To'g'ri to'rtburchakni yasash uchun qolgan uchlari koordinatalarini toping. Bunday to'rtburchaklardan nechta yasash mumkin?

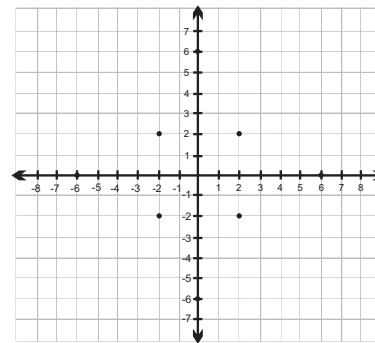

10. Berilgan nuqtalarni tutashtiring va koordinatalarini aniqlang.

11. A (-3; 3), B (3; 3), C (3; -3) va D (-3; -3) nuqtalar yordamida kvadrat yasang va kvadrat ichidan shunday nuqta topingki, natijada 5 ta kvadrat hosil qilish mumkin bo'lsin.

12. Koordinatalar sistemasida uchlari A (-4; 2), B (-4; -3), C (1; 2) va D (1; -3) shu nuqtalarda bo'lgan uchburchak yasash mumkinmi?

13. Quyidagilarga mos ko'rsatilgan nuqtalarni aniqlang va nomlang:

- to'g'ri to'rtburchak ichida joylashgan;
- faqat to'g'ri to'rtburchak ichidagi;
- faqat uchburchak ichida joylashgan;
- ham uchburchak, ham to'g'ri to'rtburchak ichidagi.

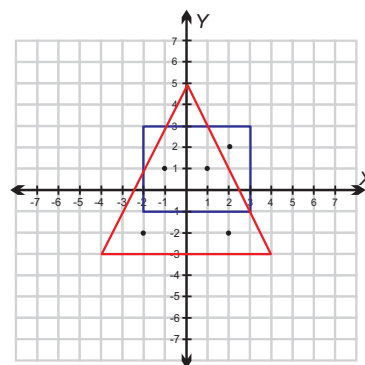

14. Koordinatalar sistemasida A (4; 3), B (-3; 4) va C (-4; -4) nuqtalarni belgilab, uchburchak yasang.

15. Kvadratning ikki uchi A (2; -2) va C (-2; 2) nuqtalarda joylashgan. Qolgan uchlarining koordinatalarini toping.



### Mustaqil ish: 16-17.

16. Koordinatalar sistemasida berilgan nuqtalarning koordinatalarini aniqlang. Nuqtalarni tartib bilan tutashtirib qanday shaklni hosil qilish mumkin?

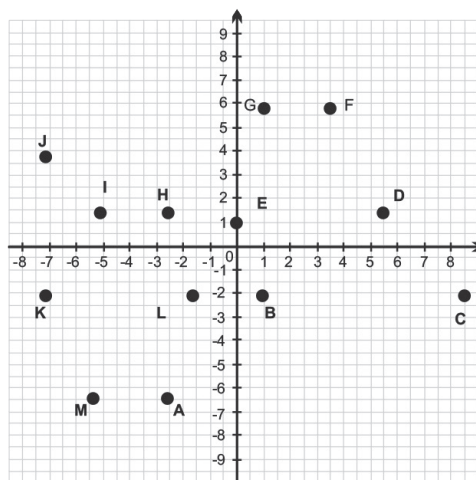
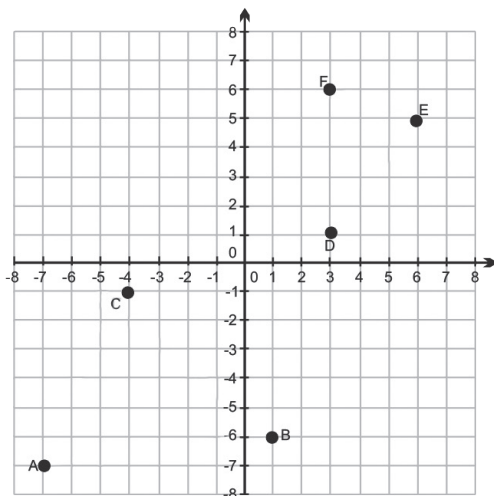

17. Uchlari A (2; 2), B (3; -2), C (-3; 2) va D (4; 2) nuqtalarda bo'lgan nechta uchburchak yasash mumkin.

## UCHBURCHAK, UNING ELEMENTLARI VA PERIMETRI



### Eslaymiz!

Rasmdagi qaysi shakllar uchburchakka o'xshamaydi?



Bir to'g'ri chiziqda yotmagan ixtiyoriy  $A$ ,  $B$  va  $C$  uchta nuqtani tutashtirishdan hosil qilingan yopiq shakl **uchburchak**dir.

$A, B, C$  nuqtalar  $\rightarrow$  uchburchak uchlari  
 $|AB| = c, |BC| = a, |CA| = b \rightarrow$  tomonlar  
 $\angle BAC, \angle ABC, \angle BCA \rightarrow$  burchaklar

Uchburchak  $ABC$  deb o'qiladi,  $\triangle ABC$  kabi belgilanadi.

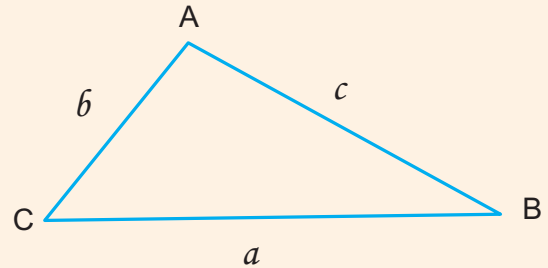

Uchburchakning ixtiyoriy bir tomoni qolgan ikki tomoni yig'indisidan kichik.



$$\begin{aligned} AB &< AC + BC \\ AC &< AB + BC \\ BC &< AB + AC \end{aligned}$$



### Guruhlarda ishlaymiz: 1–3.

1. Berilgan kesmalardan uchburchak yasash mumkinmi?

- a)  $\underline{\quad 3 \text{ cm} \quad}$   $\underline{\quad 7 \text{ cm} \quad}$   
 $\underline{\quad 9 \text{ cm} \quad}$
- b)  $\underline{\quad 4,3 \text{ cm} \quad}$   $\underline{\quad 6,5 \text{ cm} \quad}$   
 $\underline{\quad 10,1 \text{ cm} \quad}$



Uchburchakning  $\angle BAC, \angle ABC, \angle BCA$  burchaklari yig'indisi  $180^\circ$  gradusga teng.  
 $\angle BAC + \angle ABC + \angle BCA = 180^\circ$

#### Eslatma!

- Uchburchakda eng katta tomon qarshisida eng katta burchak, eng kichik tomon qarshisida eng kichik burchak joylashadi.
- Uchburchakning teng tomonlari qarshisidagi burchaklari teng bo'ladi.

2. Berilgan uchburchakning  $A$  burchagini toping.

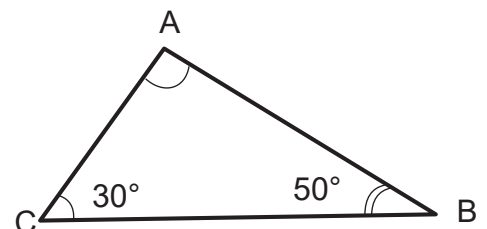





Uchburchak tomonlari uzunliklarining yig'indisi uning **perimetri** deyiladi.

$$P = |BC| + |CA| + |AB| = a + b + c$$

3. Quyidagi maydonning perimetrini toping.

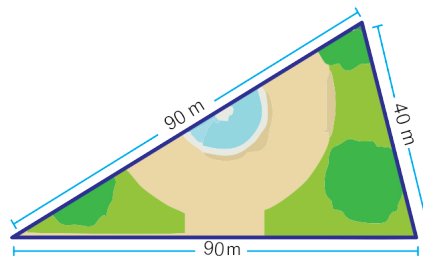

**Mustahkamlash: 4–12.**

4. Berilgan uchburchakning noma'lum burchagini toping.

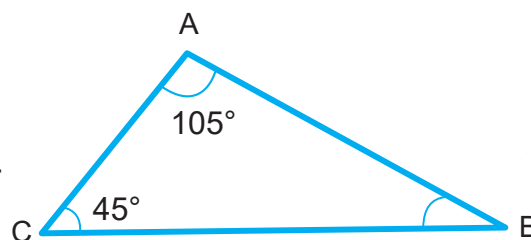

5. Berilgan uchburchakning noma'lum burchagini toping.

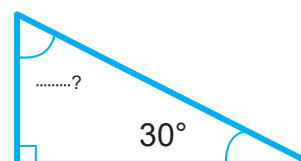

6. Uchburchaklardagi noma'lum burchaklarni aniqlang.

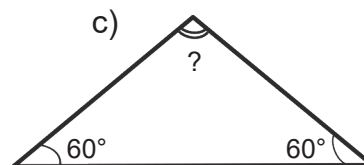
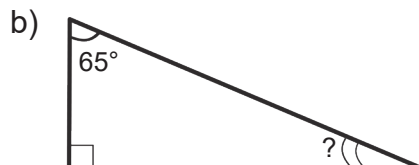
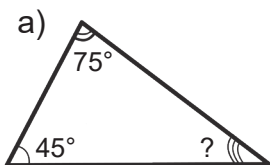

7. Eng katta perimetrga ega uchburchakni aniqlang.

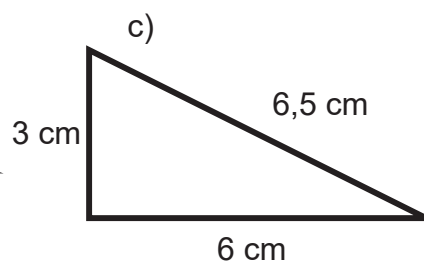
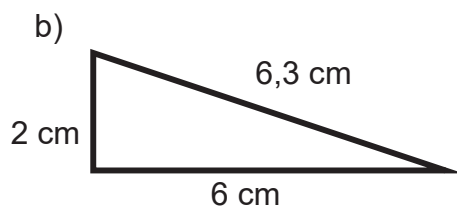
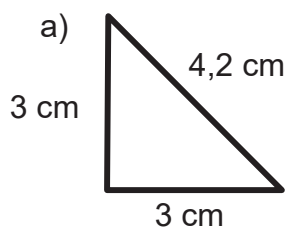

8. Bog' atrofini o'rash uchun necha metr to'siq ishlatilgan?

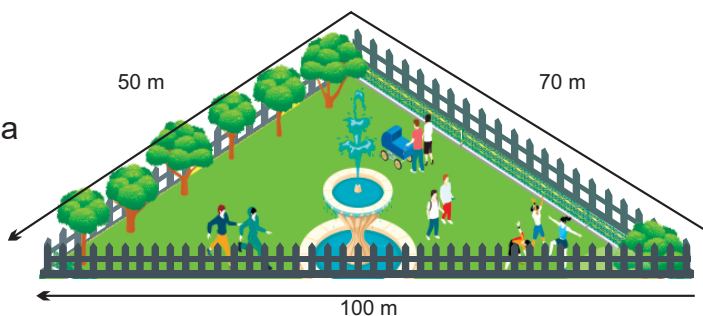

9. Uzunliklari 3, 4, 5, 6, 7 va 8 cm bo'lgan kesmalardan nechta turli tomonli uchburchak yasash mumkin?

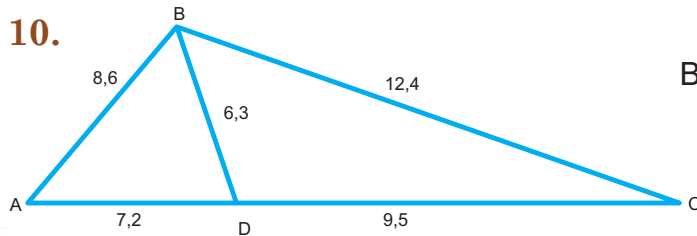

Berilgan chizmadagi uchburchaklar perimetrlarini hisoblang.

11. Berilgan chizmada uchburchaklar soni nechta?

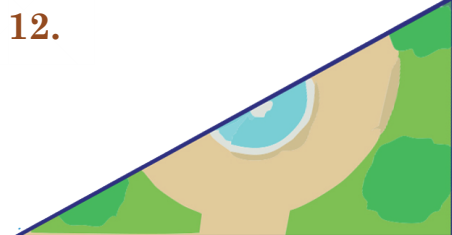
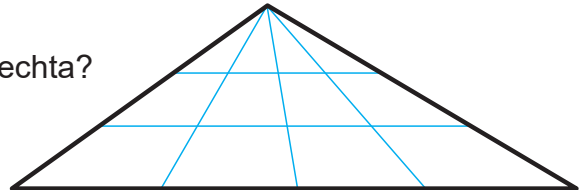

Guli tomonining uzunliklari 3 m, 4 m va 5 m bo'lgan uchburchak shaklidagi gulzori atrofida gul ekmoqda. U har 20 cm ga bir tup gul eksa, jami necha tup gul ekadi?



**Mustaqil ish: 13–16.**

13. Berilgan uchburchakning qolgan burchagini toping.

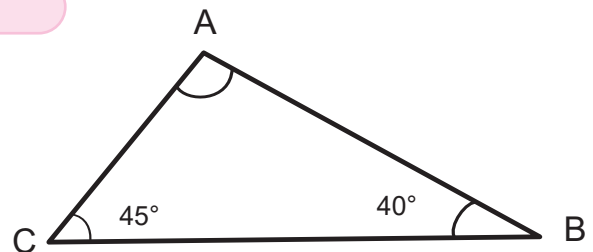

14. Jadvalni to'ldiring ( $a$ ,  $b$ ,  $c$  – uchburchak tomonlari).

$a$	$b$	$c$	Perimetri
6,5 cm	7,2 cm	8,7 cm	
	1,4 dm	1,6 dm	5,8 dm
25 cm		2,5 dm	75 cm
1,7 dm	1,7 dm		5,8 dm

15. Berilgan kesmalar uchburchakning tomonlari bo'lsa, uning perimetrini toping.

- a)  $AB = 7,6$  cm,  $BC = 4,5$  cm,  $CA = 6,3$  cm  
 b)  $PQ = 4$  cm,  $QR = 3$  cm,  $RP = 5$  cm  
 c)  $LM = 4,5$  dm,  $MN = 3,6$  dm,  $NL = 6,2$  dm

16. Uchburchakning burchaklari  $2x$ ,  $3x$ ,  $4x$  ga teng. Har bir burchak necha gradusdan?



## UCHBURCHAK TURLARI



### Eslaymiz!

Uchburchakning tomonlariga ko'ra qanday turlari bor?

Uchburchakning tomonlari	Uchburchakning tomonlari	Ko'rinishi (rasmi)
Uchala tomoni o'zaro teng: $AB = BC = AC$	Teng tomonli (muntazam)	
Ikkala tomoni o'zaro teng: $AB = BC$	Teng yonli	
Uchala tomoni turli uzunlikka ega	Turli tomonli	



### Guruhlarda ishlaymiz: 1–4.

1. Bayroqchalardagi harflarni tartiblash orqali marraga yetish uchun eng qisqa yo'lni toping.

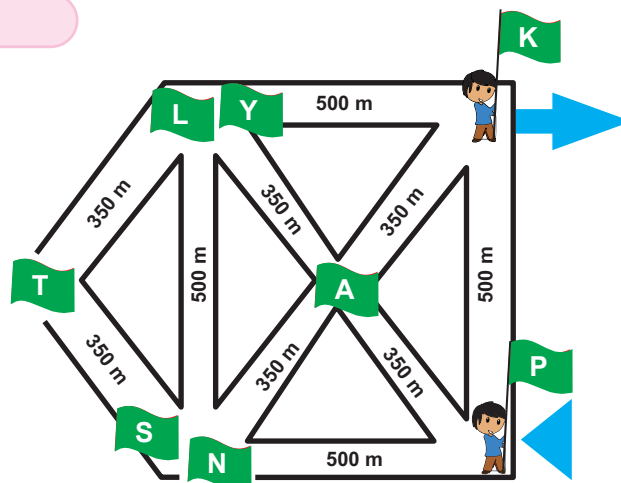

2. Yuqoridagi rasmda qanday uchburchaklar berilgan?
3. Teng yonli uchburchakning perimetri 60 cm. Uning yon tomoni 22 cm bo'lsa, asosini toping.
4. Teng tomonli (muntazam) uchburchakning perimetri 45 cm bo'lsa, uning tomonini aniqlang.



### Mustahkamlash: 5–9.

5. Uchburchakning perimetri 24 cm. Uning qo'shni tomonlari 8 cm va 9 cm. Uchinchi tomonining uzunligi qancha?
6. Uchburchakning har bir tomoni perimetrining uchdan biriga teng. Bu qanday uchburchak?

7. Berilgan uchburchaklarning tomonlariga ko'ra turini aniqlang va perimetrini toping.

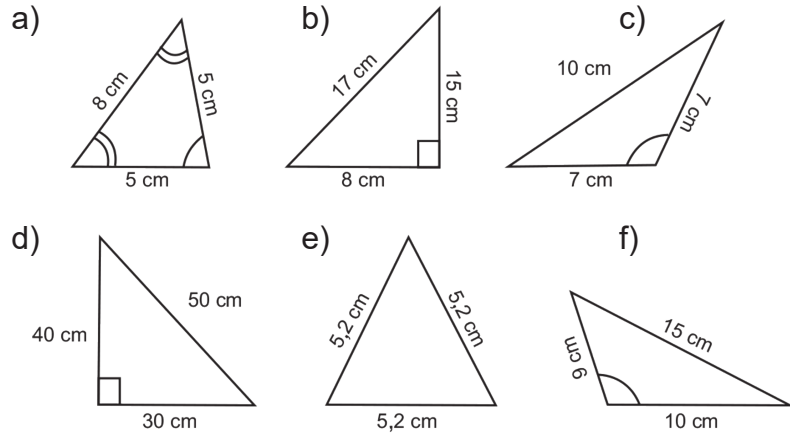

8. Teng yonli uchburchakning teng burchaklari  $55^\circ$  bo'lsa, uning uchinchi burchagini toping.

9. Uzunliklari 7 cm va 8 cm bo'lgan kesmalardan uchburchaklar yasang. Hosil bo'lgan uchburchaklarning perimetrini toping.



Uchburchak burchaklariga ko'ra ham uch turli bo'ladi.



Uchburchakning burchaklari	Uchburchakning nomlanishi	Ko'rinishi (rasmi)
Hamma burchaklari o'tkir	O'tkir burchakli uchburchak	
Burchaklaridan biri to'g'ri	To'g'ri burchakli uchburchak	
Burchaklaridan biri o'tmas	O'tmas burchakli uchburchak	



Guruhlarda ishlaymiz: 10–12.

10. To'g'ri burchakli uchburchaklarning qolgan burchaklarini aniqlang.

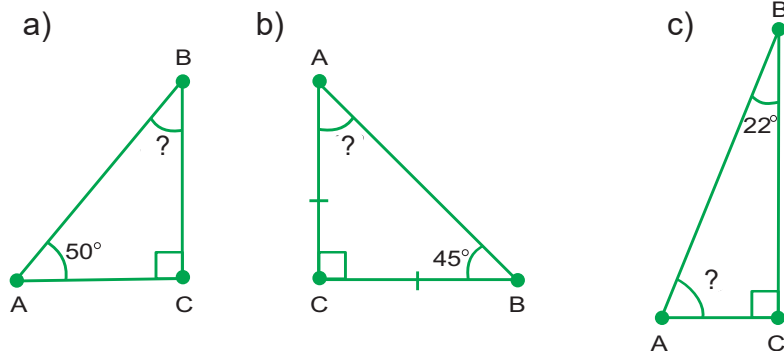

11. Teng yonli uchburchakning qo'shni burchaklari ayirmasi  $24^\circ$  teng bo'lsa, uning barcha burchaklarini toping.

12. Koordinatalar sistemasida berilgan nuqtalarni belgilab uchburchak turini aniqlang.

- a) A (-1; 0), B (2; 3) va C (5; 0)      b) F (-2; -2), N (-2; 3) va M (1; -2)  
 c) D (0; 0), T (-3; 4) va H (5; 0)      d) L (-4; 6), U (2; -3) va E (-4; -3)



**Mustahkamlash: 13–18.**

13. Qanday uchburchaklarni ko'ryapsiz?

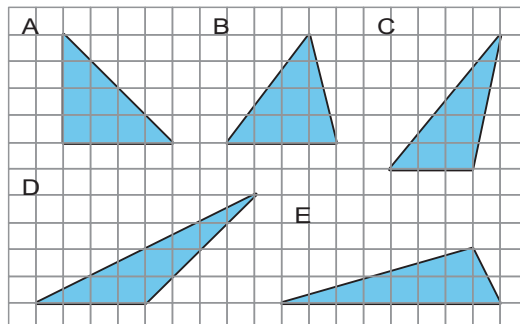

14. Berilgan burchaklar asosida uchburchak turini aniqlang.

- a)  $90^\circ, 45^\circ, 45^\circ$       b)  $60^\circ, 60^\circ, 60^\circ$       c)  $80^\circ, 60^\circ, 40^\circ$   
 d)  $130^\circ, 40^\circ, 10^\circ$       e)  $90^\circ, 35^\circ, 55^\circ$       f)  $92^\circ, 38^\circ, 50^\circ$

15. Teng yonli uchburchakning uchidagi burchagi  $70^\circ$  gradusga teng. Uning qolgan burchaklarini aniqlang.

16. Uchburchaklarni tomonlariga ko'ra turlarga ajrating.

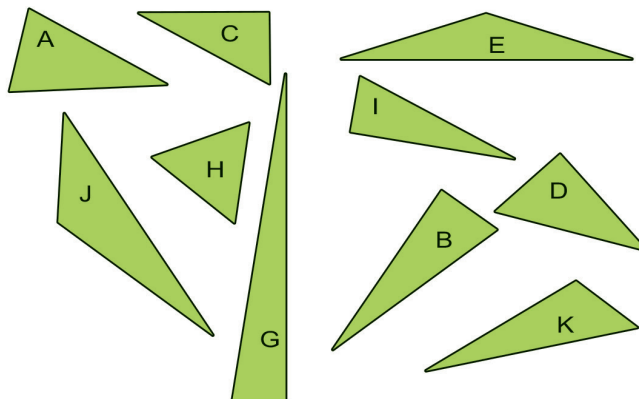

17. Muntazam uchburchakning bir tomoni 4,3 dm ga teng. Uning perimetrini toping.

18. Barcha uchburchaklarning turlarini aniqlang.

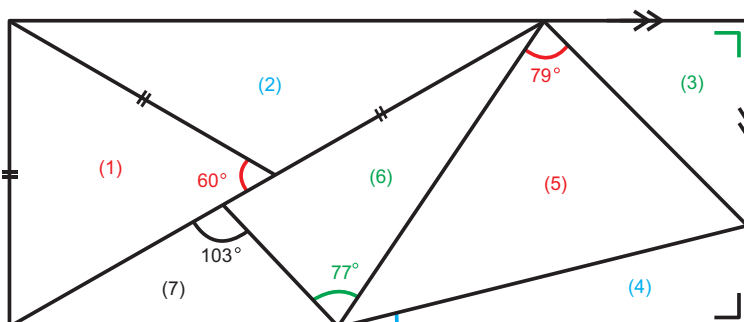



### Mustaqil ish: 19–24.

19. Berilgan uchburchaklarning perimetrlarini toping.

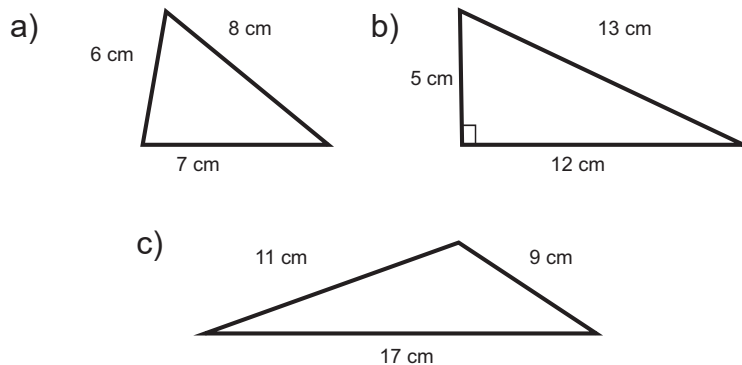

20. Uchburchakning tomonlariga ko'ra turlarini aniqlang.

- a) 6 cm, 3 cm, 5 cm      b) 6 cm, 6 cm, 6 cm      c) 7 cm, 7 cm, 5 cm  
 d) 8 cm, 12 cm, 10 cm      e) 3 cm, 4 cm, 5 cm      f) 3,5 cm, 3,5 cm, 4,5 cm

21. Berilgan uchburchaklarning uchinchi burchagini toping.

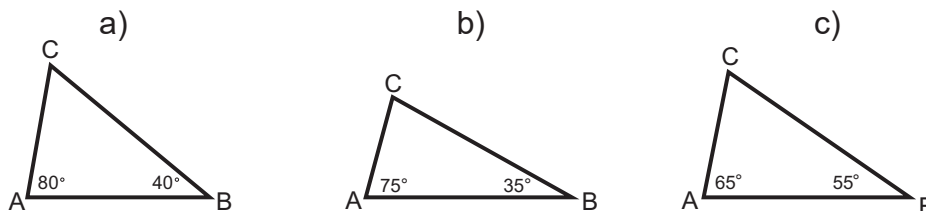

22. Quyidagidek burchaklar va tomonlarga ega uchburchak bo'lishi mumkinmi? Javobingizni asoslang.

- a)  $110^\circ, 60^\circ, 30^\circ$       b)  $70^\circ, 70^\circ, 70^\circ$       c)  $80^\circ, 35^\circ, 65^\circ$   
 d) 7 cm, 3 cm, 4 cm      e)  $50^\circ, 50^\circ, 90^\circ$       f) 10 cm, 12 cm, 2 cm

23. Bo'yalgan shaklning perimetrini toping.

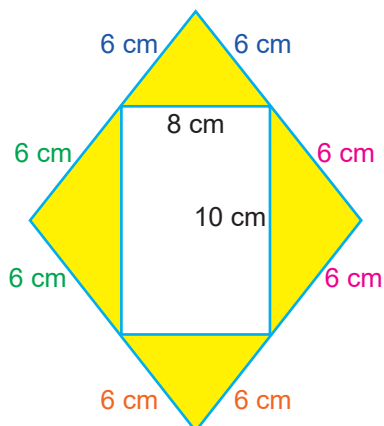

24. Shaklning perimetrini toping.

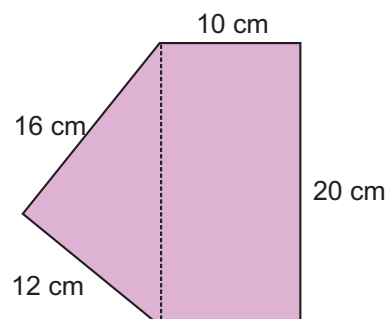

## UCHBURCHAKNING YUZI



## Eslaymiz!

To'g'ri to'rtburchakning yuzi nimaga teng?

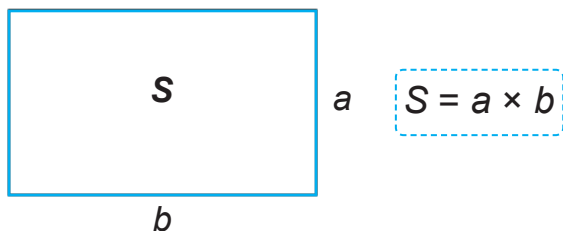

To'g'ri to'rtburchakni qanday shakllar bilan to'ldirish mumkin?

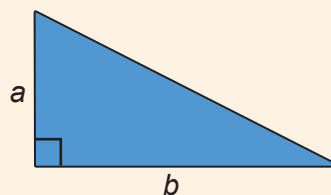
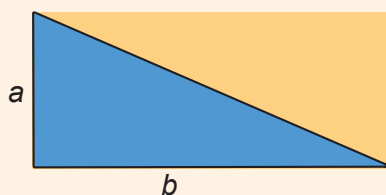

To'g'ri burchakli uchburchakning yuzi to'g'ri burchakka yopishgan tomonlari ko'paytmasining yarmiga teng.

$$S = \frac{1}{2}ab$$

Uchburchakning bir tomoni va shu tomonga tushirilgan perpendikulyar orqali uchburchak yuzini topish mumkin:

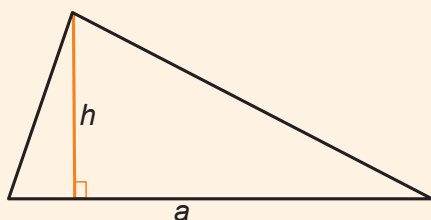

$$S = \frac{1}{2}ha$$

$h$  – uchburchak balandligi



## Guruhlarda ishlaymiz: 1–5.

- Rasmdagidek tomonlari 3,8 cm va 4,6 cm bo'lgan to'g'ri burchakli uchburchak yuzini toping.

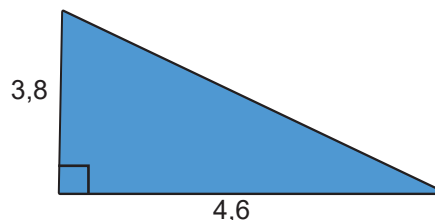

- Quyidagi bo'yalgan shakl yuzini toping.

4,2 cm

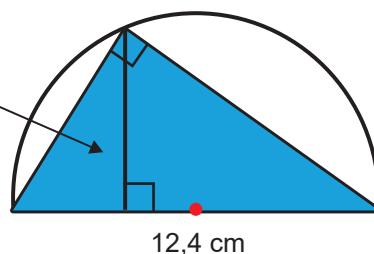

3. Quyidagi uchburchaklar ichida eng katta yuzga ega bo'lganini aniqlang.

a)

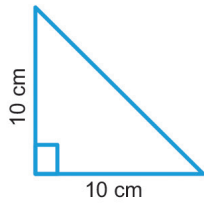

b)

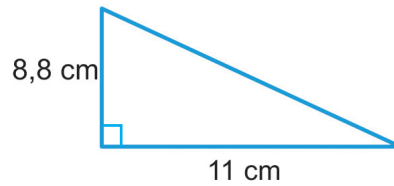

c)

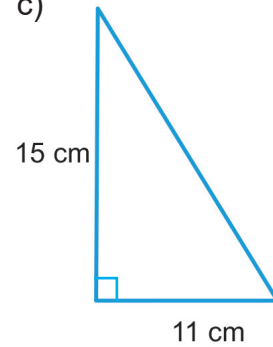

4. To'g'ri burchakli teng yonli uchburchakning yuzi  $50 \text{ dm}^2$  ga teng. Uning teng tomonlari uzunligini toping.
5. Uchburchakning yuzi  $36 \text{ cm}^2$  ga teng bo'lib, uchburchakning  $a$  tomoniga tushirilgan balandligi 12 cm ga teng.  $a$  tomonning uzunligini toping.



**Mustahkamlash: 6–15.**

6. Quyidagi bo'yalgan yuzalar ichidan qaysilari teng?

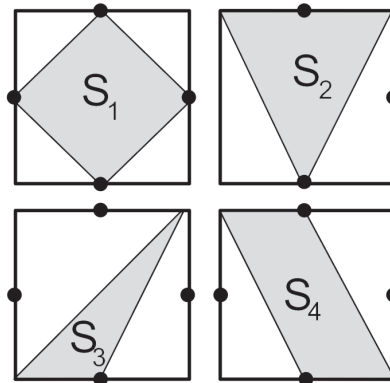

7. Uchburchakning bir tomoni uzunligi 10 cm ga, unga tushirilgan balandlik 5,4 cm ga teng. Bu uchburchakning yuzini toping.
8. Katak daftarda  $A$  nuqtani belgilang.  $A$  nuqtadan o'ng tomonga 8 cm 5 mm li  $AB$  kesma chizing. Shu kesmaning  $A$  nuqtasida  $BAC 90^\circ$  li burchak yasang.  $AC$  kesmaning uzunligini 6 cm 4 mm qilib belgilang.  $ABC$  uchburchak yuzini hisoblang.
9. Quyidagi uchburchaklarning yuzlarini toping.

a)

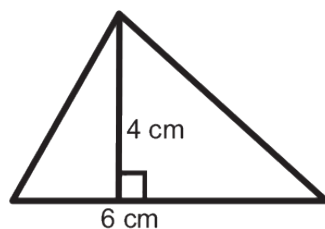

b)

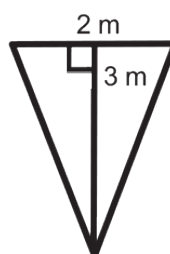

c)

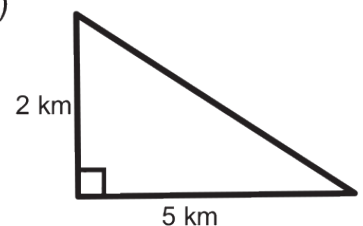



10. Quyidagi shakl yuzini hisoblang.

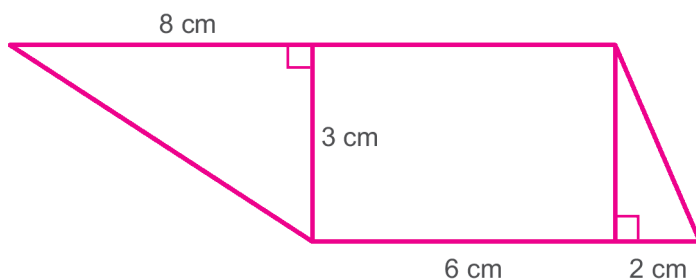

11. Perpendikulyar tomonlari 2,5 dm va 4,8 dm bo'lgan to'g'ri burchakli uchburchak yuzini hisoblang.

12. Jadvalni to'ldiring.

	Tomoni	Balandligi	Yuzasi
a	8 cm	7 cm	
b		9 cm	36 cm <sup>2</sup>
c		5 cm	10 cm <sup>2</sup>
d	4 cm		6 cm <sup>2</sup>
e	6 cm		21 cm <sup>2</sup>
f	8 cm	11 cm	

13. Quyidagi bo'yalgan shakl yuzini toping.

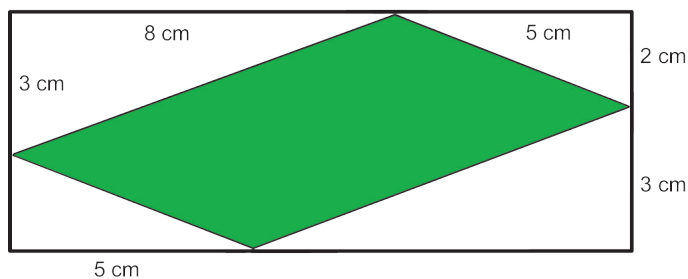

14. Berilgan uchburchaklar yuzini toping.

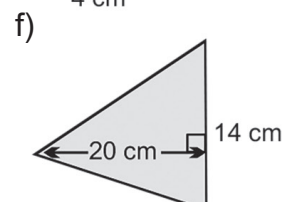
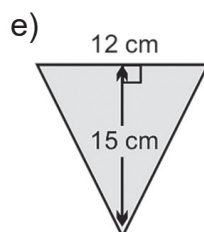
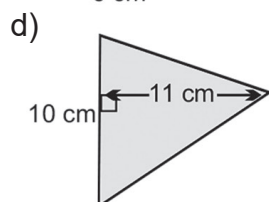
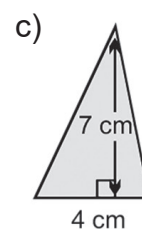
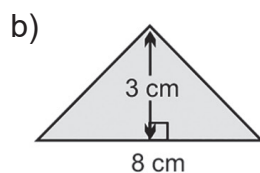
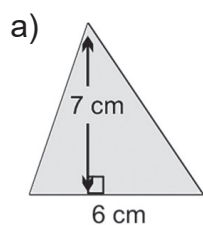

15. Quyidagi bo'yalgan shakl yuzini hisoblang.

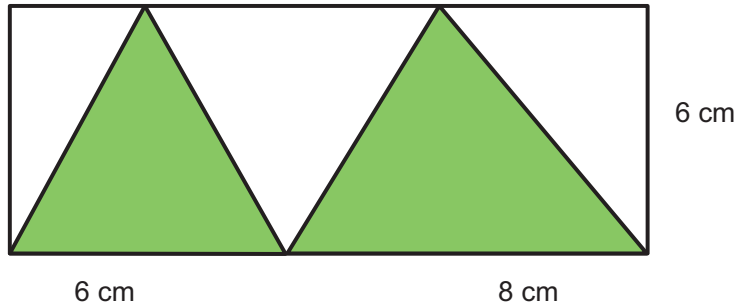

**Qiziqarli matematika: 16.**

16. Uchta kartochka bir xil, ular qaysilar?

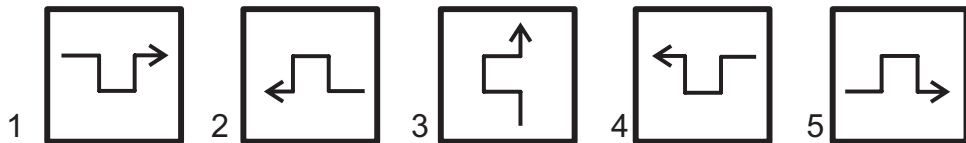

**Mustaqil ish: 17–20.**

17. Uchburchaklar yuzini toping.

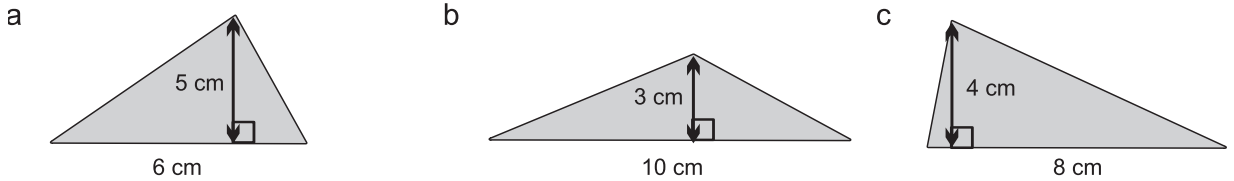

18. Quyidagi uchburchaklar ichida eng katta yuzga ega bo'lganini aniqlang.

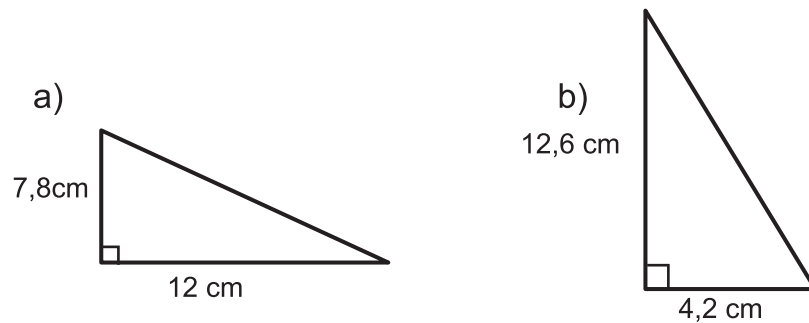

19. To'g'ri to'rtburchakning bo'yi va eni berilgan. Quyidagi bo'yalgan shakl yuzini hisoblang.

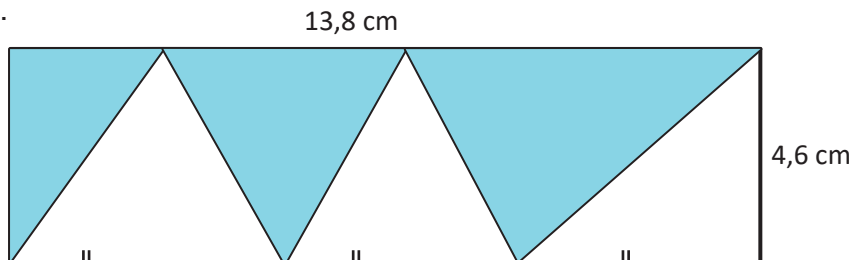

20. Quyidagi shakl yuzini hisoblang.

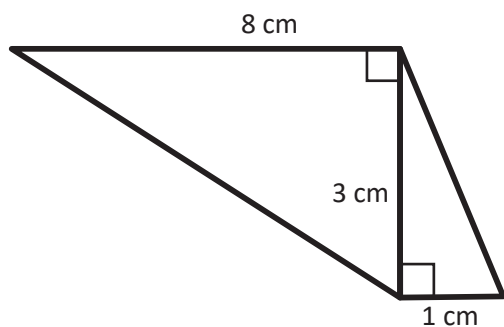

21. Bo'yalgan soha yuzini toping.

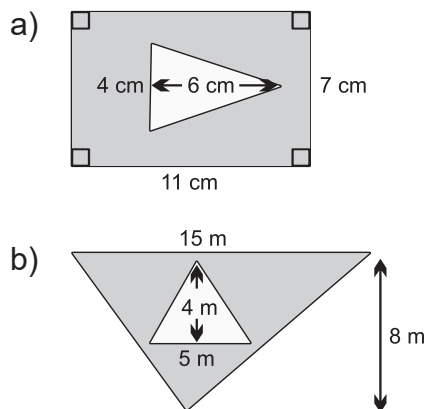

**KATAKLI QOG'OZDA YUZLARNI HISOBLASH**



**Eslaymiz!**

Shakllar yuzi qanday hisoblangan?

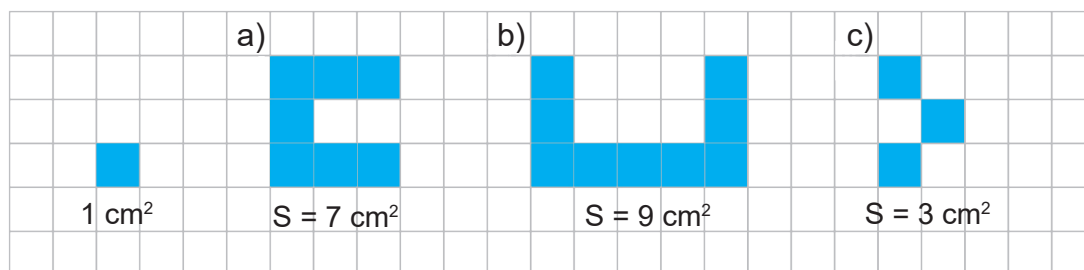

Katakli qog'ozda berilgan ko'pburchakning yuzini hisoblash uchun

"Pik formulasi": 
$$S = \frac{M}{2} + N - 1$$

$M$  – ko'pburchak chegarasida yotgan tugun nuqtalar soni

$N$  – ko'pburchak ichida yotgan tugun nuqtalar soni

$N = 4 \times 3 = 12$

$M = 2 \times (3 + 6) = 18$

$$S = \frac{18}{2} + 12 - 1 = 9 + 11 = 20 \text{ (cm}^2\text{)}$$

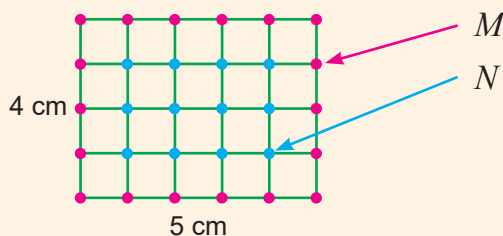

**Guruhlarda ishlaymiz: 1–5.**

1. Shaklning yuzini toping.

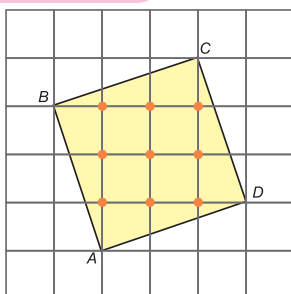

$$S = \square + \frac{\square}{2} - 1 = ?$$

2. Quyidagi shakl yuzini toping.

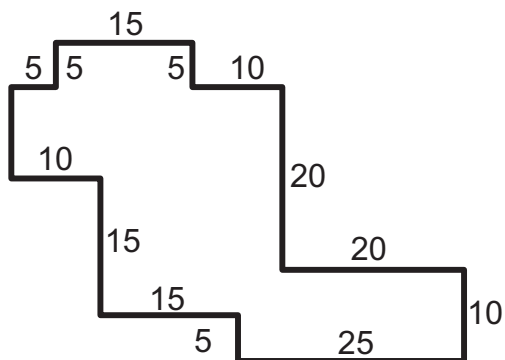

3. Qaysi shaklda bo'yalgan yuz eng kichik?

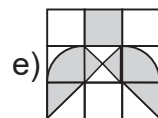
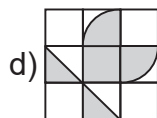
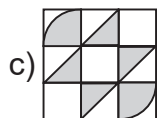
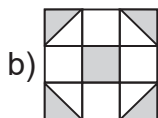
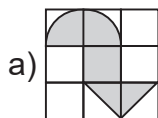

4. Katta to'g'ri to'rtburchak turli o'lchamdagi kvadratlardan tashkil topgan. Eng kichik kvadratlarning yuzi 1 ga teng. Katta to'rtburchakning yuzi nimaga teng?

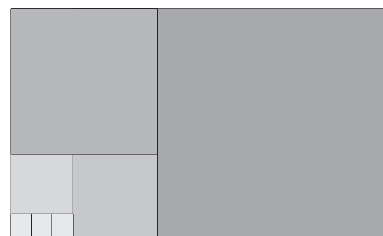

5. Rasmda nechta uchburchak bor?

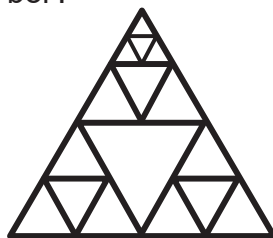

**Qiziqarli matematika: 6-7.**

6. Harri Potterning sehrli ko'zoynagi bor, undan foydalanganda barcha yashil ranglar oq, oq ranglar yashil bo'lib ko'rinadi. U shu ko'zoynagi bilan quyidagi to'g'ri to'rtburchakka qarasa, uni qanday ko'radi?

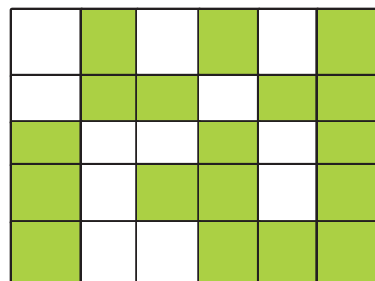

7.

			?

Sehrli shaharga kirish uchun quyidagi 4x4 jadvalni , , va belgilar bilan to'ldiring. Har bir ustunda va har bir satrda belgilar faqat bir marta qatnashsin.

So'roq belgisi o'rniga qanday belgi joylanadi?



**Qiziqarli matematika: 8–15.**

8. Agar bitta katakning yuzi 1 ga teng bo'lsa, N harfining yuzi qancha?

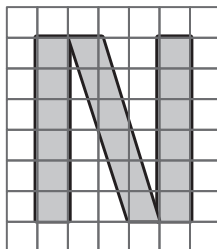

9. Har bir katakning yuzi 2 ga teng bo'lsa, qora kataklar yuzi qancha?

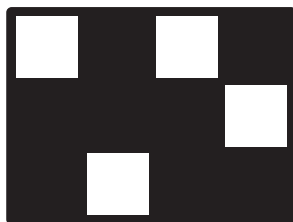

10. Zeboda jumboqning to'rtta qismi bor, ammo rasmni to'ldirish uchun faqat uchta qism kerak. Qaysi qism ortiqcha?

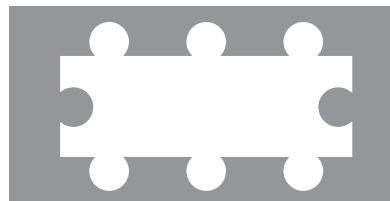
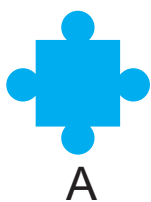

11. Quyidagi shakllarning yuzlarini toping.

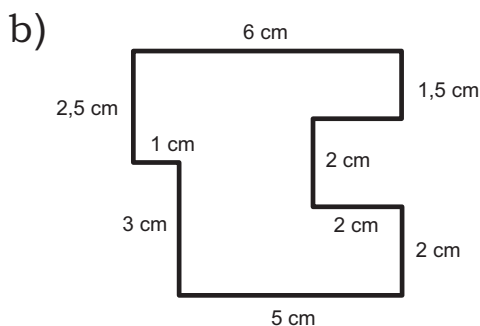
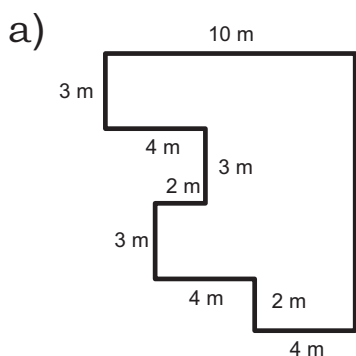

12. Rasmda ko'rsatilgani kabi 930 soni katakchalar yordamida yasalgan, 806 sonini yozish uchun nechta katakcha o'z rangini almashtirishi kerak?

13. Rasmda berilgan har bir katak yuzi 2,2 ga teng bo'lsa, bo'yalgan jami yuz qancha?

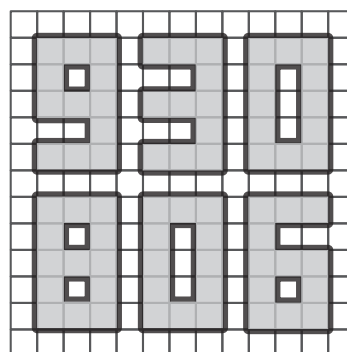

14. Akrom katakchali daftardan ikki xil turdagi shakl kesib olyapti. Akromga rasmdagi qayiqni butunlay yopish uchun kerak bo'ladigan shakllarning eng kichik miqdori qancha?

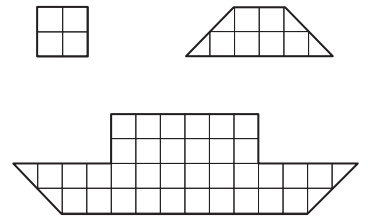

15. Katakning o'lchami  $5 \times 5$  (mm). Shakllarning yuzini toping.

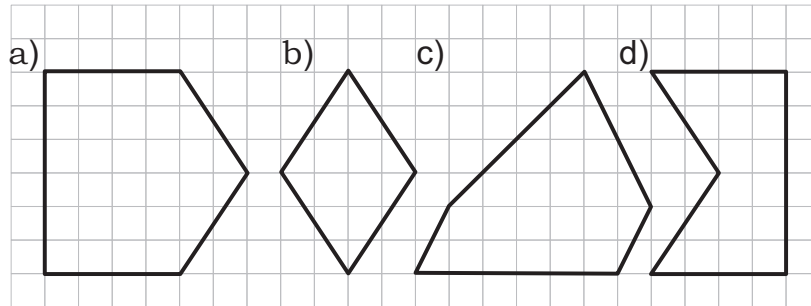

**Mustaqil ish: 16–18.**

16. Shakllarning yuzini toping?

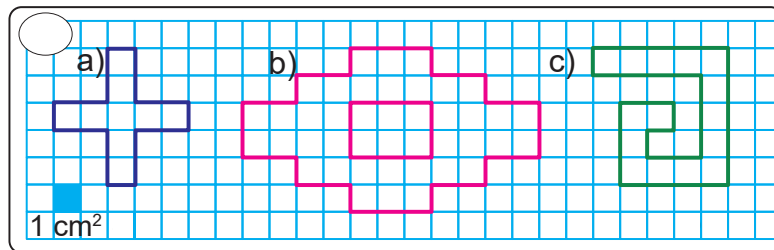

17. Shakllarning yuzini "Pik formulasi" dan foydalanib toping.

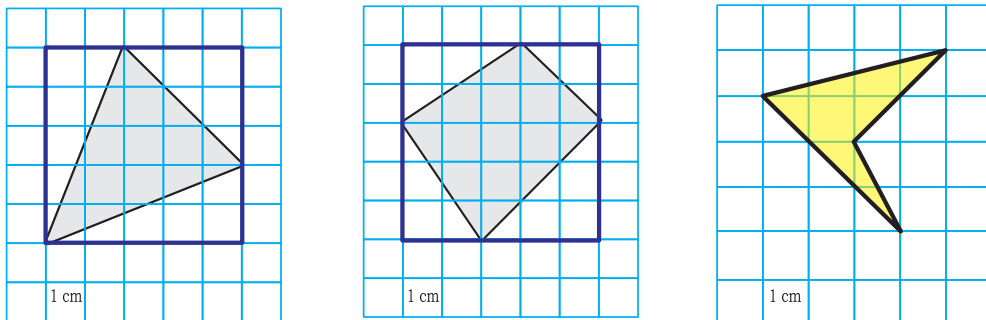

18. Shakllarning yuzini toping.

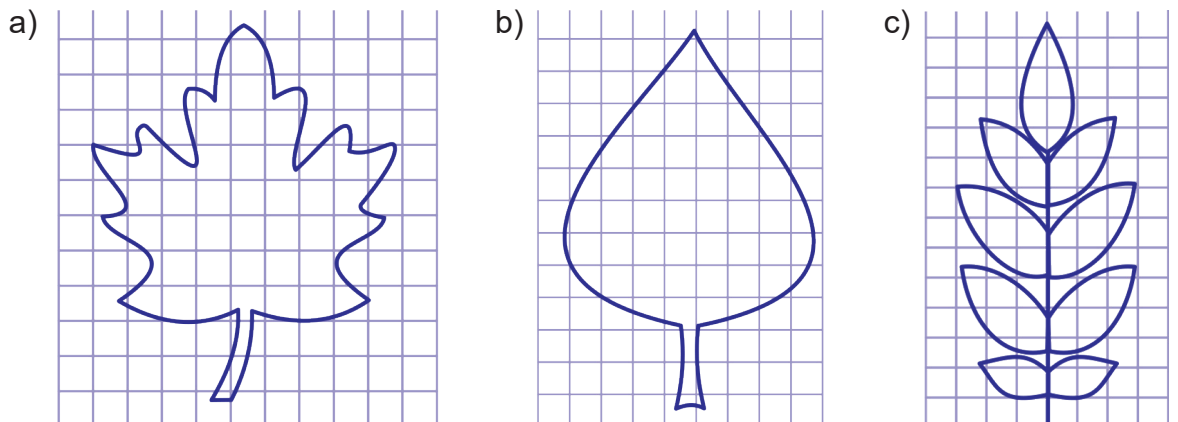



## Eslaymiz!

Berilgan nuqtadan bir xil masofada joylashgan nuqtalar to'plami **aylana** deyiladi.

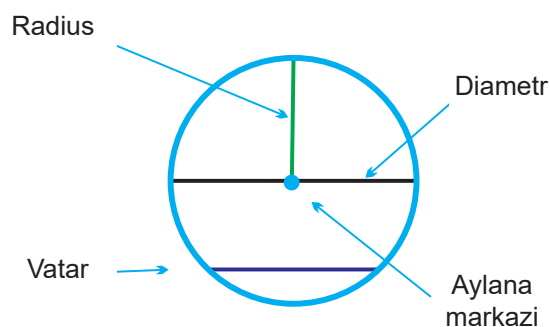

Tekislikning aylana bilan chegaralangan sohasi **doira** deyiladi.

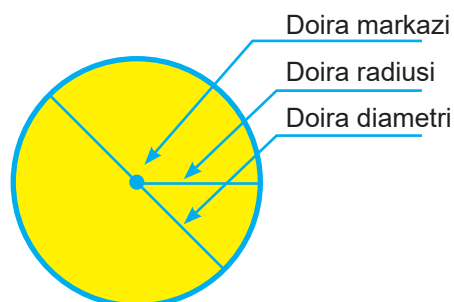

Aylananing ikki nuqtasini tutashtiruvchi kesma aylana **vatar** deyiladi.

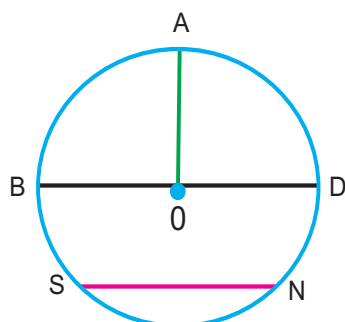
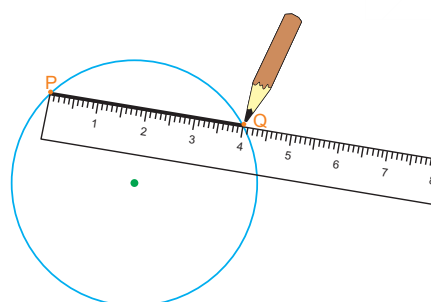

Aylana markazidan o'tuvchi vatar **diametr** deyiladi. Diametr ikkita radius uzunligiga teng.

SN – vatar

$r = OA$  – radius

$d = BD$  – diametr

$d = 2r$

BD diametrni vatar ham deyish mumkin.



Aylananing ikki nuqtasini birlashtirgan bo'lagi **aylana yoyi** deyiladi.

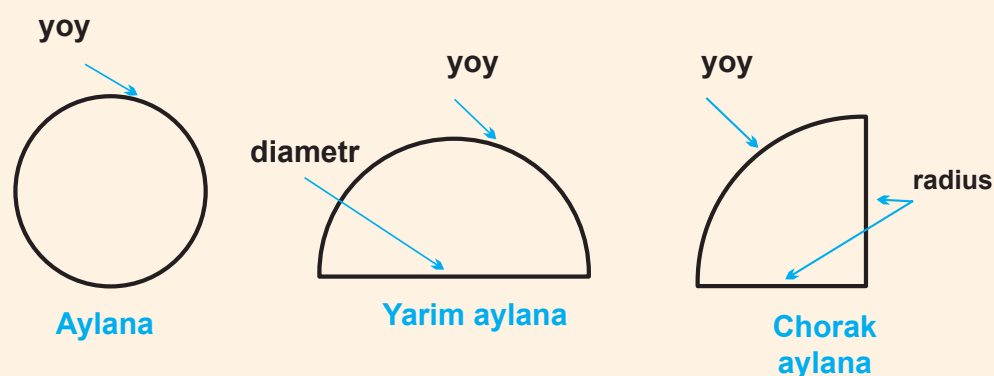



## Guruhlarda ishlaymiz: 1–5.

1. Hisoblashlarni tushuntiring.

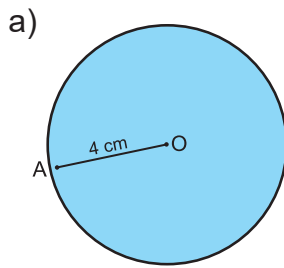

$$\text{Diametr} = 2 \times \text{radius}$$

$$\text{Radius} = 4 \text{ cm}$$

$$\text{Diametr} = 2 \times 4 = 8 \text{ cm}$$

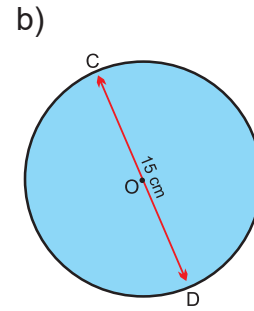

$$\text{Radius} = \text{diametr} \div 2$$

$$\text{Radius} = \frac{1}{2} \times \text{diametr}$$

$$\text{Diametr} = 15 \text{ cm}$$

$$\text{Radius} = 15 \div 2 = 7,5 \text{ cm}$$

2. Berilgan rasmlardan aylana va doira shakllarini toping.



3. Sirkul yordamida radiusi 3 cm bo'lgan aylana yasang. Uning diametri uzunligini toping. Unda 4 cm li aylana vatarini chizing.

4. Atrofimizda ko'p jismlar aylana shaklida.



Yana qanday aylanasimon buyum va narsalarni bilasiz?

5. Aylanalarning radiusi berilgan bo'lsa, diametrini, diametri berilgan bo'lsa, radiusini toping.

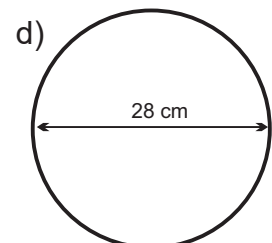
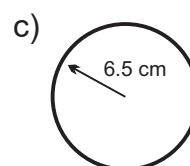
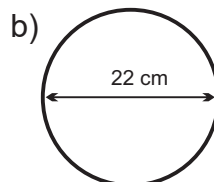
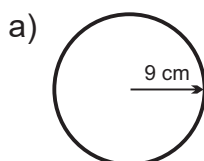





**Mustahkamlash: 6–11.**

**6. Noma'lumlarni toping.**

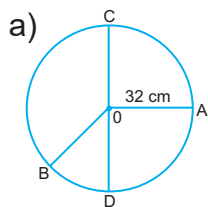

OA = 32 cm  
 OB = \_\_\_\_\_ cm  
 CD = \_\_\_\_\_ cm

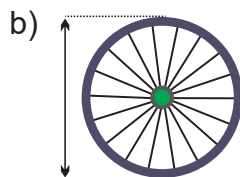

$h = 60$  cm  
 diametr = \_\_\_\_\_ cm  
 radius = \_\_\_\_\_ cm

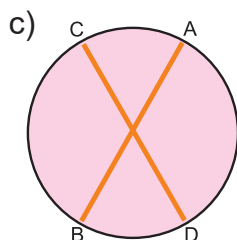

AB = 18 cm, CD = \_\_\_\_\_ cm

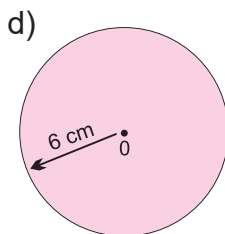

Diametr = \_\_\_\_\_ cm

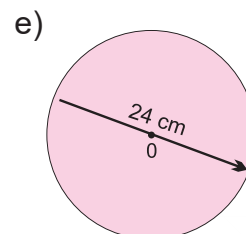

Radius = \_\_\_\_\_ cm

**7. Jadvalni to'ldiring.**

Aylana	Radius	Diametr
W	13 cm	_____ cm
X	_____ cm	13 cm
Y	_____ cm	38 cm
Z	22 cm	___ cm

**8. Diametrlar qanchaga teng?**

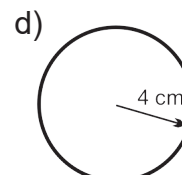
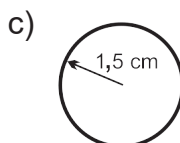
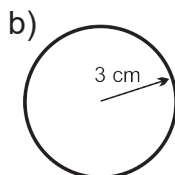
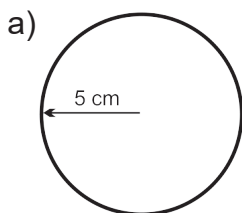

**9. Berilgan aylanalarning radiusini toping.**

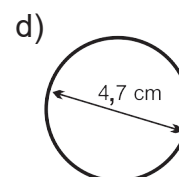
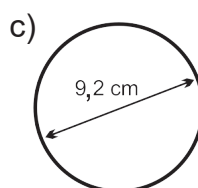
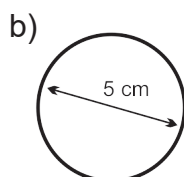
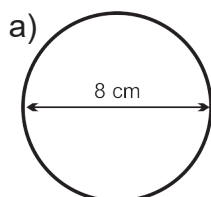

**10. Chizg'ich va sirkul yordamida aylana chizing.**

Radius = 4 cm

Diametr = 6 cm

Diametr = 8 cm

Radius = 3,5 cm

11. Berilgan rasmdan foydalanib katta aylananing diametrini toping.  $CB = 4$  cm.

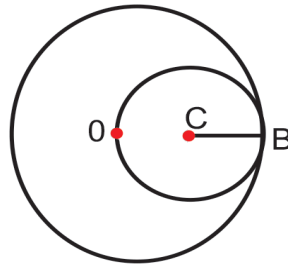

**Qiziqarli matematika: 12.**

12. Qaysi halqani kesganda qolgan uchta halqa alohida bo'lib qoladi?

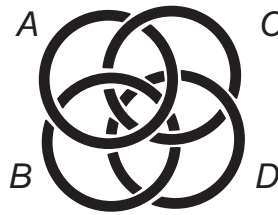

**Mustaqil ish: 13–16.**

13. Quyidagi rasmda markazi O bo'lgan aylana va unda chizilgan aylana elementlarini ajrating.

- OA = .....
- OB = .....
- OC = .....
- EF = .....
- MN = .....
- PQ = .....

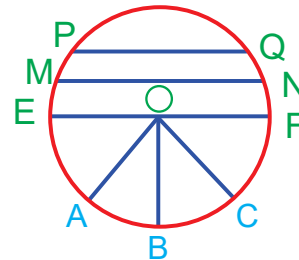

14. Jadvalni to'ldiring.

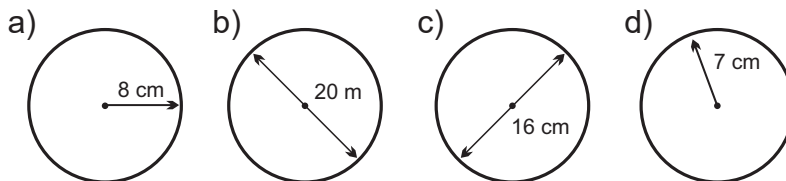

Aylana	Radius	Diametr
A	8 m	
B		20 m
C		16 cm
D	7 cm	

15. Qorboboning bo'yi uzunligini toping.

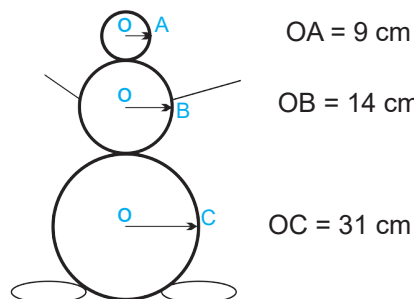

## AYLANA UZUNLIGI VA DOIRA YUZI



Soat atrofining to'liq uzunligi qanday o'lchandi? Sizda-chi?



Dumaloq jismning radiusi yoki diametri qancha katta bo'lsa, o'lchovingiz ham shuncha katta bo'ldi. To'g'rimi yoki noto'g'ri?



Aylana uzunligini  $C$ , diametrini  $d$ , radiusini  $r$  deb belgilang.

$$C = \pi \times 2 \times \text{radius} = 2\pi r$$

$$C = \pi \times \text{diametri} = \pi d$$

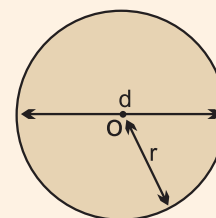

Har qanday aylana uzunligining diametrga nisbatini 3,14 yoki  $\frac{22}{7}$  ga teng deb olamiz. Bu qiymat yunoncha " $\pi$ " (pi) harfi bilan ifodalanadi.



## Guruhlarda ishlaymiz: 1–3.

1. Hisoblashlarni tushuntiring.

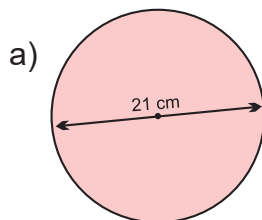

$$\text{Doira aylanasi} = \pi d = \frac{22}{7} \times 21 = 66 \text{ cm}$$

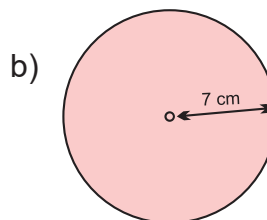

$$\text{Doira aylanasi} = 2\pi r = 2 \times \frac{22}{7} \times 7 = 66 \text{ cm}$$

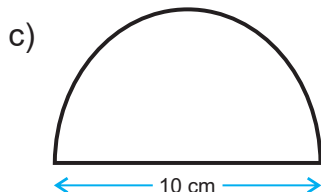

$$\text{Yoy uzunligi} = \frac{1}{2} \times \pi d = \frac{1}{2} \times 3,14 \times 10 = 15,7 \text{ cm}$$

$$\text{Yarim aylana perimetri} = \text{yoy uzunligi} + \text{diametr} = 15,7 + 10 = 25,7 \text{ cm}$$

- Radiusi 5 m bo'lgan favvara atrofi panjara bilan o'raldi. Taxminan necha metr panjara ishlatilgan? ( $\pi = 3,14$  deb oling).
- Aylana uzunligi  $12\pi$  ga teng. Uning diametrini toping.

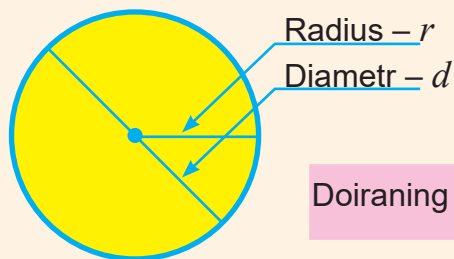

Doiraning yuzi:  $S = \pi r^2$

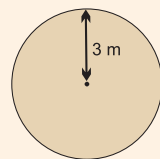

$$S = \pi r^2 = 3,14 \cdot 3^2 = 3,14 \cdot 9 = 28,26 \text{ m}^2$$



### Guruhlarda ishlaymiz: 4–5.

4. O – doiraning markazi. Har bir doiraning yuzini toping.

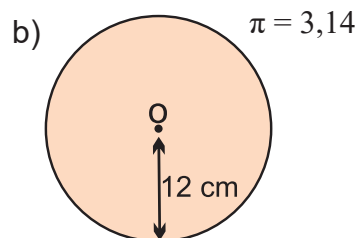
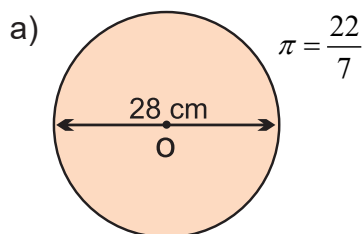

5. Doira bo'laklarining radiusini o'lchab, yuzini toping.

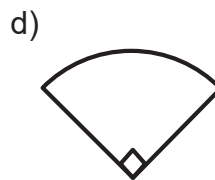
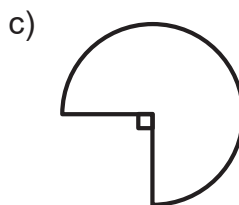
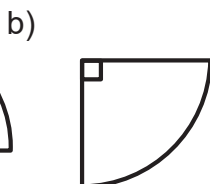
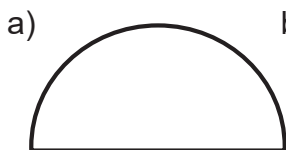

### Mustahkamlash: 6–12.

6. Diametri 49 cm bo'lgan g'ildirak 924 cm masofani bosib o'tdi. U necha marta to'liq aylangan?

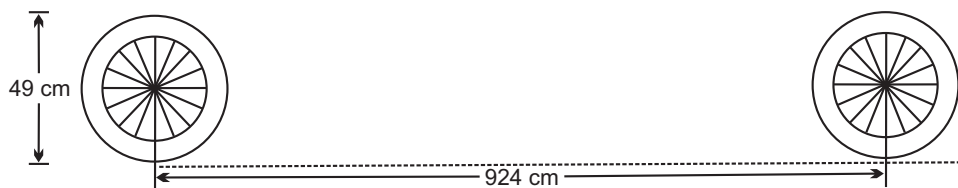

7. Quyida berilgan shakldagi egri chiziq uzunligini toping. ( $\pi = \frac{22}{7}$ )

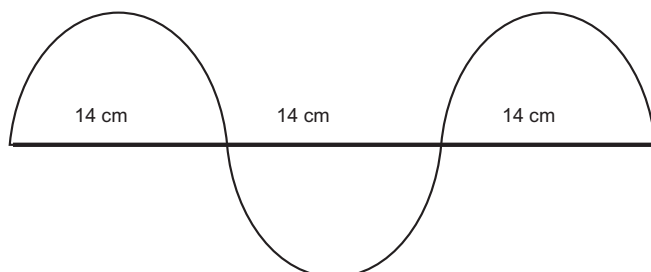

8. Doira yuzi  $64\pi$  ga teng. Uning aylana uzunligini toping.

9. Doiraning radiusi 4 dm ga teng. Uning yuzini toping ( $\pi = 3,14$ ).

10. Doiralar yuzini hisoblang.

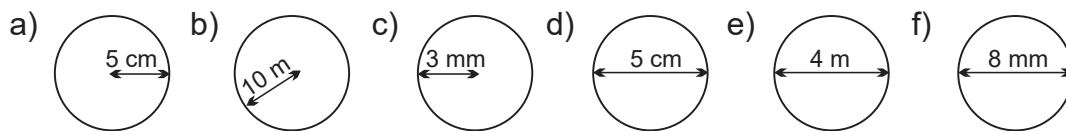

11. Noma'lum radiuslarni toping.  $\pi = \frac{22}{7}$

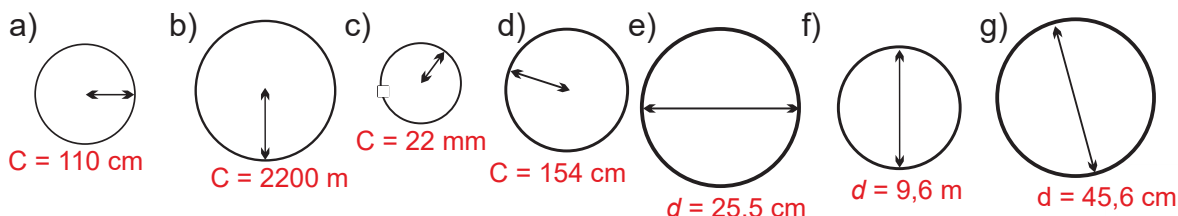

12\*. Quyidagi bo'yalgan soha perimetrini va yuzini toping. ( $\pi = \frac{22}{7}$ ).

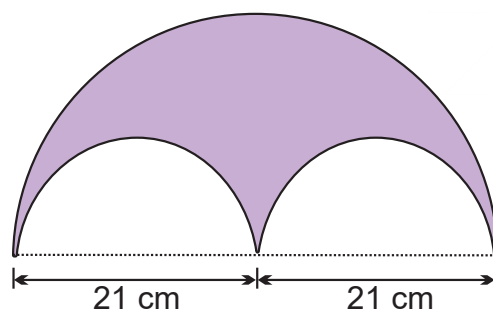

**Qiziqarli matematika: 13–15.**

13. Quyidagi rasmda beshta aylana berilgan, har bir aylananing yuzi 2 ga teng. Kvadratning uchlari aylana markazida joylashgan bo'lsa, bo'yalgan soha yuzini toping.

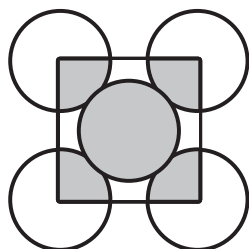

14. Qaysi sonlar bir vaqtda aylana va to'g'ri to'rtburchakda joylashgan, ammo uchburchakka tegishli emas?

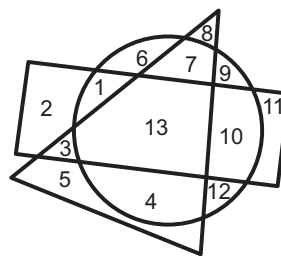

$\pi$  soni

Sayyoramizning o'rtacha diametri 12 742 kilometr. Aylanasida esa, ya'ni ekvator uzunligi 40 000 kilometr.

$$40\ 000 \div 12\ 742 = 3,1392246115 \approx 3,14$$

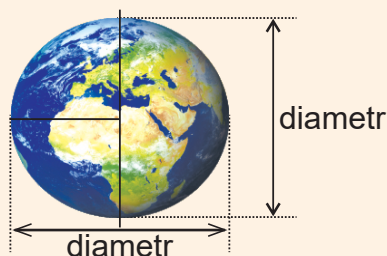

15. A va B nuqtalardagi tangalar C va D nuqtalarga aylantirildi. 50 so'mlik tanga 10 ta to'liq aylanishdan keyin C nuqtaga yetib bordi.

AC va BD kesmalar uzunligi bir-biriga teng bo'lsa, 200 so'mlik tanga aylantirilgandan keyin D nuqtada qanday ko'rinishda bo'ladi? ( $\pi = 3$  deb oling.)

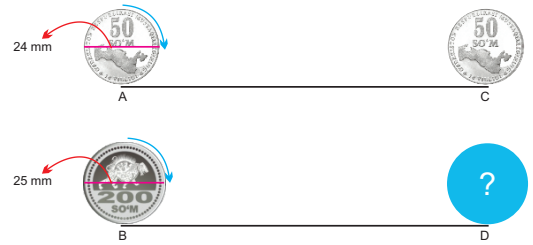

### Mustaqil ish: 16–20.

16. Doira yuzi hamda aylanasi uzunligini toping.

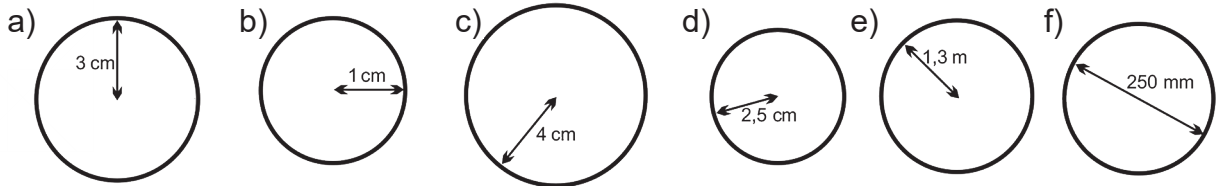

17. Dumaloq plastinkaning perimetri 132 cm, uning yuzini toping.  
 18. Agar doiraning yuzi  $616 \text{ cm}^2$  bo'lsa, uning perimetrini toping.  
 19. Mototsikl g'ildiragining diametri 63 cm. 99 km masofani bosib o'tish uchun u necha marta aylanadi?  
 20. Doiraviy maydonning radiusi 21 m, uning perimetri va yuzini toping ( $\pi = \frac{22}{7}$ ).

## MURAKKAB SHAKLLARNING YUZINI HISOBLASH



### Guruhlarda ishlaymiz: 1.

1. Katta doira radiusi 15 cm. Kichikroq doiraning radiusi 8 cm. bo'yalgan sohaning yuzi qancha? ( $\pi = 3,14$ )

$$\text{Katta doira yuzi } S = \pi \times r^2 = 3,14 \times 15 \times 15 = 765,5 \text{ cm}^2$$

$$\text{Kichik doira yuzi } S = \pi \times r^2 = 3,14 \times 8 \times 8 = 200,96 \text{ cm}^2$$

$$\text{Bo'yalgan sohaning yuzi } S = 765,5 - 200,96 = 564,54 \text{ cm}^2$$

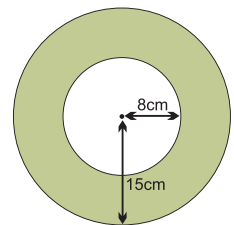

### Mustahkamlash: 2–12.

2. Aylanma yo'lining ichki va tashqi diametri berilgan. Aylanma yo'lining maydonini toping ( $\pi = \frac{22}{7}$ ).

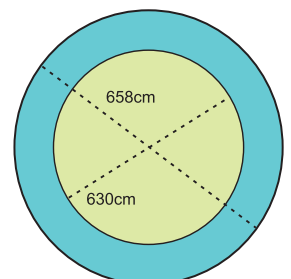

3. Berilgan shakllarning yuzini toping.

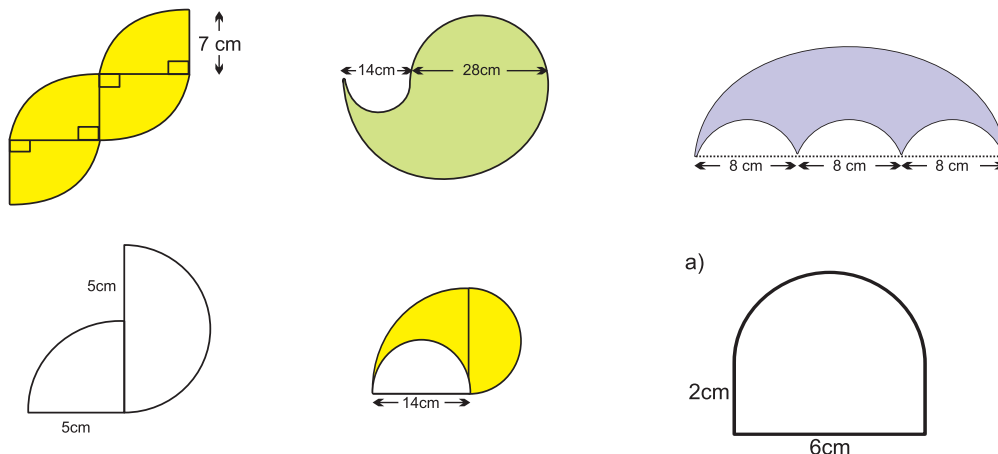

4. Quyidagi shaklning yuzini toping.

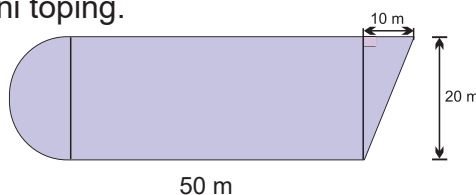

5. To'g'ri burchakli uchburchak va yarim aylanadan iborat shaklning perimetri va yuzini toping ( $\pi = 3,14$ ).

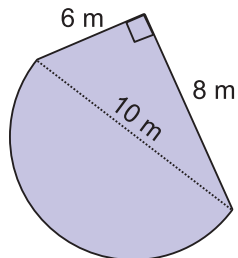

6. Quyidagi shakl perimetrini va yuzini toping ( $\pi = \frac{22}{7}$ ).

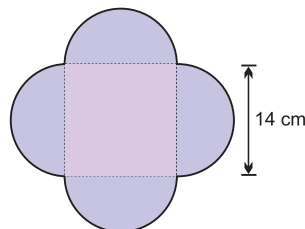

7. Shakl ikkita aylana bilan berilgan. Bo'yalgan soha yuzini toping ( $\pi = 3,14$ ).

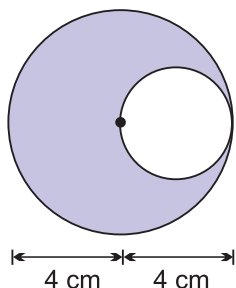

8\*. Kvadratning tomoni 6 cm ga teng,  $x = 2$  cm. Bo'yalgan sohaning yuzini toping.

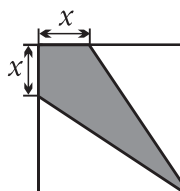

9\*.  $10 \times 10$  kvadratning burchaklaridan  $2 \times 2$  kvadratchalar qirqib olingan. Ushbu shakldagi bo'yalgan bo'lakning yuzini toping.

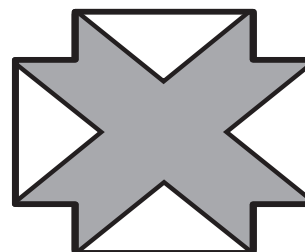

10. Poyga yo'li halqa shaklida bo'lib, ichki aylanasi 220 m, tashqi aylanasi 308 m. Yo'ning kengligini toping.

11\*. To'g'ri to'rtburchak 7 ta kvadratdan tashkil topgan. Qora rangdagi kvadratning tomoni 1 ga teng, kulrang kvadratning tomoni 3 ga teng. A kvadratning yuzini toping.

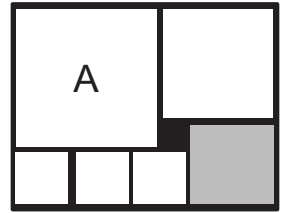

12. Berilgan shakllarning yuzini toping.

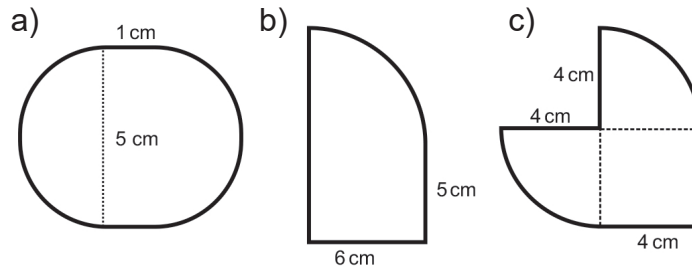

 **Mustaqil ish: 13–15.**

13. Quyidagi shakl yuzini toping.

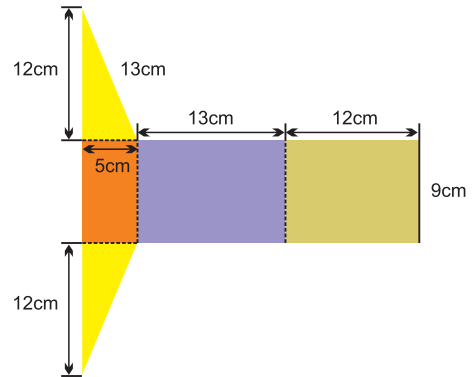

14. Quyidagi shakl yuzini toping.

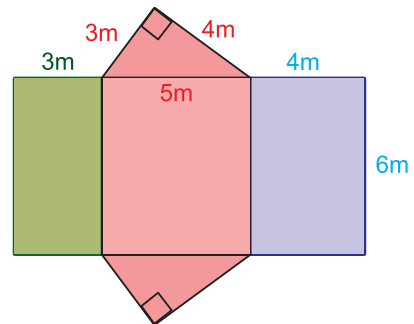

15. Quyidagi shakl yuzini toping.

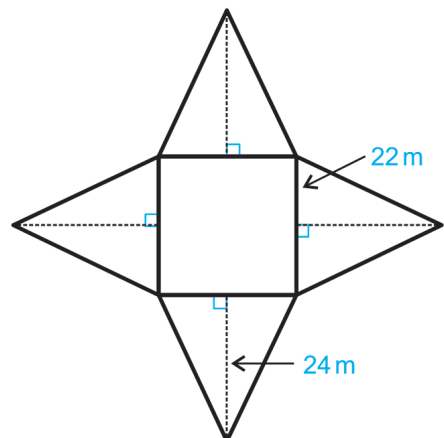



## FAZOVIY SHAKLLAR HAJMI



Eslaymiz!

Qanday fazoviy shakllarni ko'ryapsiz?



Kuboid va kubning to'la sirt yuzi va hajmi qanday topiladi?

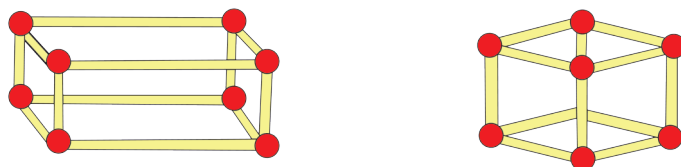

Alisherning kichik kuboid bilan tutashtirilgan ikkita akvariumi bor. Unga akvariumning hajmini topishga yordamlashamiz.

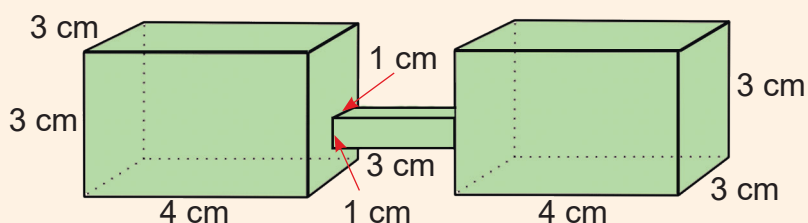

Har bir katta akvariumning hajmini toping:  $V = abc = (4 \times 3) \times 3 = 36 \text{ cm}^3$

Birlashtiruvchi kuboidning hajmini toping:  $V = (2 \times 1) \times 3 = 2 \times 3 = 6 \text{ cm}^3$

Akvariumning har bir qismining hajmlarini qo'shing:  $V = 36 + 36 + 6 = 78 \text{ cm}^3$

Akvariumning hajmi  $78 \text{ cm}^3$  ni tashkil qiladi.



Mustahkamlash: 1–7.

1. Fazoviy jismlarning hajmini toping.

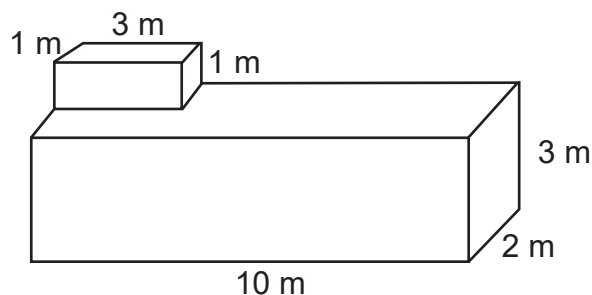
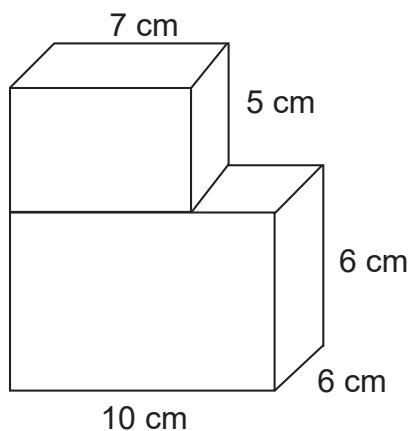

2. Har bir kubning hajmi 1 birlikka teng bo'lsa, jismlarning hajmini toping.

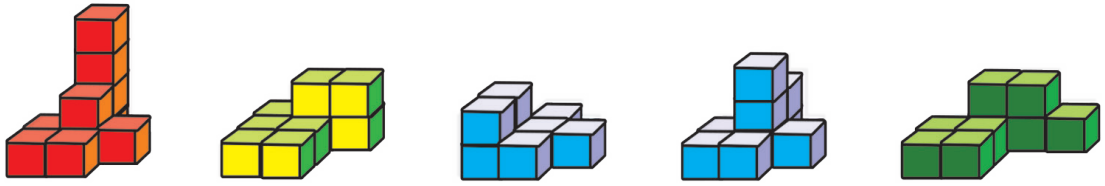

3. Qirqimdan qaysi fazoviy shaklni yasash mumkin? Uning to'la sirt yuzi va hajmini toping.

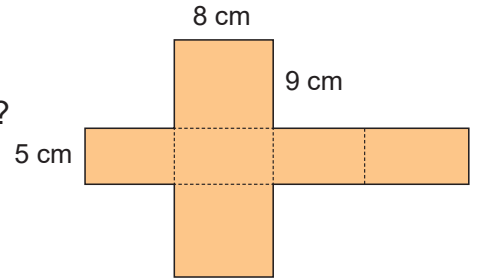

4. Fazoviy jismlarning hajmini toping.

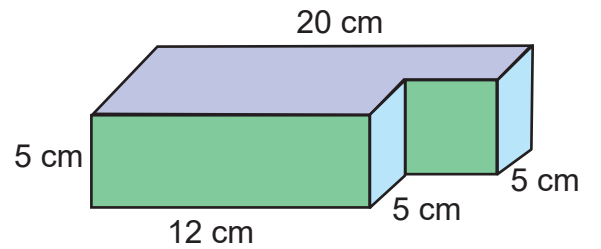
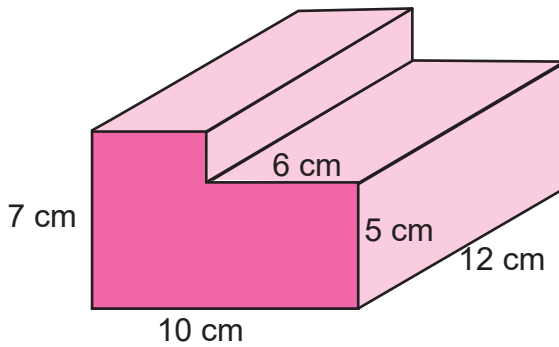

5. Fazoviy jismlarning hajmini taqqoslang.

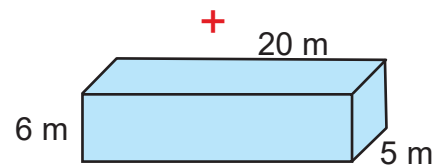
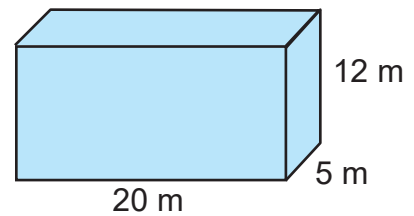
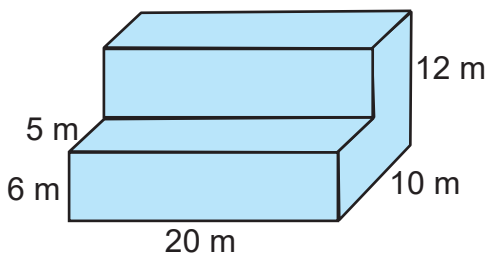

6. Fazoviy jismlarning hajmini toping.

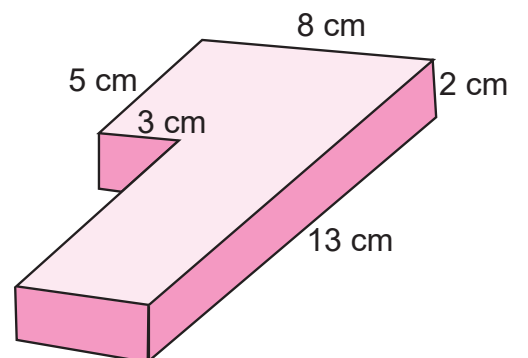
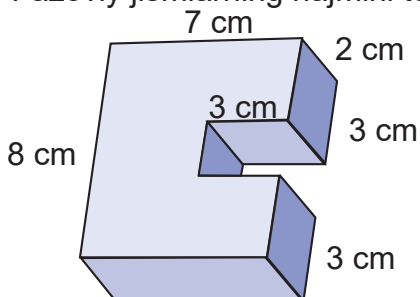

7. Fazoviy jismlarning hajmini toping.

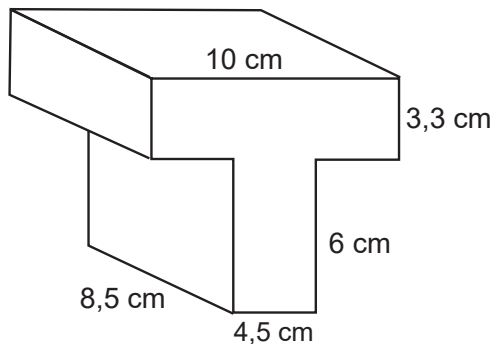
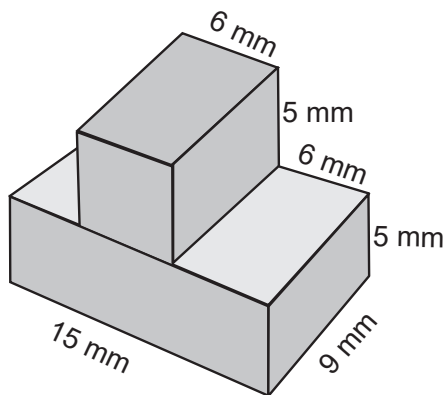
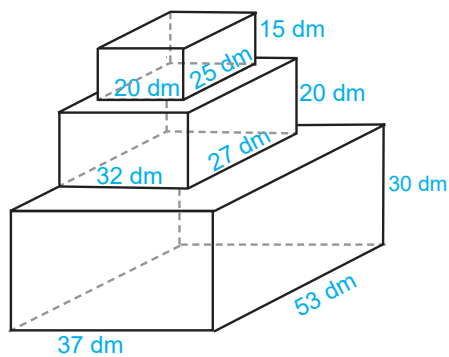
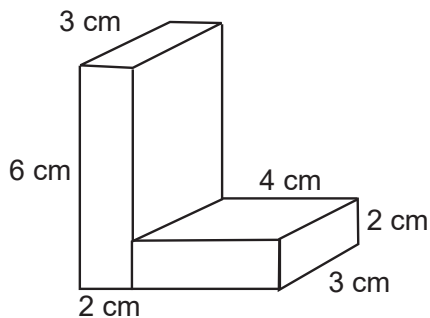

**Mustaqil ish: 8–10.**

8. Qirqimdan qaysi fazoviy shaklni yasash mumkin? Uning to'la sirt yuzi va hajmini toping.

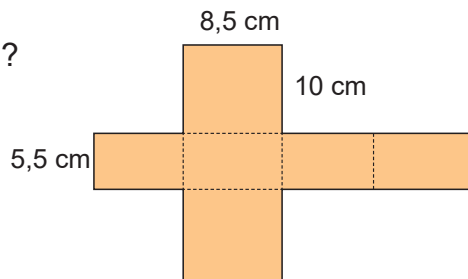

9. Fazoviy jismning hajmini toping.

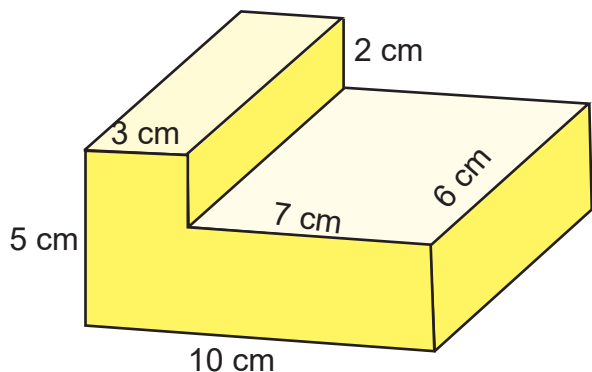

10. Rasmdagi jihozlarning hajmini uyda mustaqil o'lchashlar o'tkazib toping.



## O'LCHOV BIRLIKLARI ORASIDAGI MUNOSABATLAR



## Uzunlik o'lchov birliklari

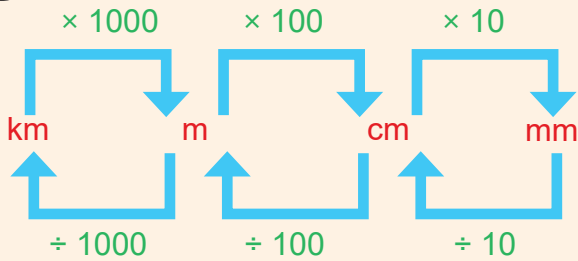

$$1 \text{ m} = 100 \text{ cm}$$

$$0,1 \text{ m} = 10 \text{ cm}$$

$$0,01 \text{ m} = 1 \text{ cm}$$



## Guruhlarda ishlaymiz: 1–5.

## 1. Metr va santimetrda ifodalang.

a) 6,13 m

b) 16,01 m

c) 7,10 m

## 2. Bo'sh joylarni to'ldiring.

a) 0,6 m = \_\_\_ cm

b) 0,615 km = \_\_\_ m

c) 1,85 cm = \_\_\_ mm

d) 2,5 m = \_\_\_ cm

e) 85,5 m = \_\_\_ cm

f) 0,85 m = \_\_\_ cm



## Og'irlik o'lchov birliklari

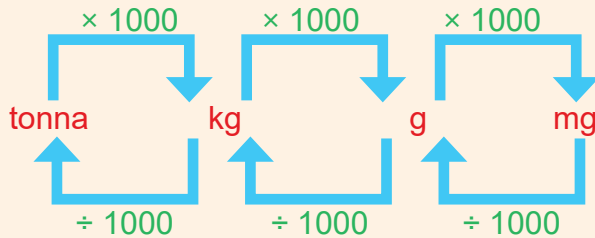

$$1 \text{ kg} = 1000 \text{ g}$$

$$0,1 \text{ t} = 100 \text{ kg}$$

$$0,01 \text{ kg} = 10 \text{ g}$$



## 3. Kilogrammda ifodalang va o'nli kasr ko'rinishida yozing.

a) 5 kg 813 g

b) 457 g

c) 2307 g

d) 7 kg 97 g

e) 1 kg 2 g

f) 14 835 g.

## 4. Tonna va kilogrammlarda ifodalang.

a) 2,783 t

b) 45,01 t

c) 25,019 t



## Vaqt o'lchov birliklari

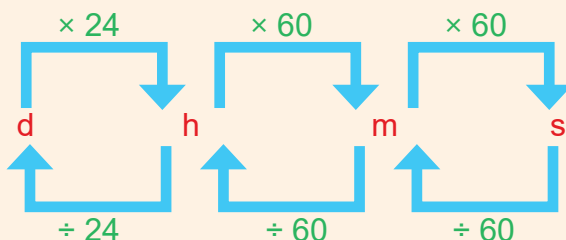

$$1 \text{ h} = 3600 \text{ s}$$

$$0,1 \text{ h} = 6 \text{ m}$$

$$0,01 \text{ h} = 0,6 \text{ m}$$



5. Minutlarda ifodalang.

- a) 0,2 h                      b) 0,5 h                      c) 0,25 h                      d) 1,5 h



**Mustahkamlash: 6–14.**

6. Ifodalang.

- a) metrda: 3,25 km; 0,042 km; 18,5 dm; 250 cm; 0,7 cm; 62 mm.  
 b) kilogrammda: 0,5 t; 1,5 t; 500 g; 1500 g; 0,8 t; 28,7 t.  
 c) soatda: 0,5 d; 4 d; 50 min; 30 min; 90 min; 0,5 min; 128 s.

7. Jadvalni to'ldiring.

Metr	Santimetr	Millimetr
		1 mm
		10 mm
		34,5 mm
	50,7 cm	
	75 cm	
0,855 m		
10,3 m		
150 m		

Kilogramm	Gramm	Milligramm
	0,5 g	
	0,85 g	
		220 mg
		325 mg
0,050 kg		
0,750 kg		
22,5 kg		
175,5 kg		

8. Miqdorlarni taqqoslang.

- a) 324,17 kg va 320,78 kg                      b) 1,2 t va 1643,3 kg                      c) 98,52 m va 65,39 m  
 d) 1272 m va 1,8 km                      e) 23,5 °C va 13,59 °C

9. Jadvalda 3 nafar o'g'il bolaning bo'yi metrda ko'rsatilgan. Balandliklarni santimetrda ifoda eting.

Ism	Bo'y
Samir	1,4
Rasul	1,26
Maqsud	1,32

10. Sherali maktablararo 1 kilometrlik poygada yugurmoqda. Agar u 2 m/s tezlikda yugursa, marraga yetish uchun qancha vaqt ketadi?

11. A va B shaharlari bir-biridan 11,8 km, C va D shaharlari bir-biridan 11500 metr masofada joylashgan bo'lsa, qaysi shaharlar o'rtasida ko'proq masofa bor?

12. Futbol maydoni aynan 1,32 ha o'lchamga ega. U necha kvadrat metrni tashkil etadi?

13. Jahongir qo'l tozalash vositasi sotib oldi. Shishada 2500 ml suyuqlik bor. Buni litrda qanday ifodalash mumkin?

### Kattalik birliklari va ularning belgilarini yozish qoidalari

To'g'ri	Noto'g'ri
20 °C	20°C
80 km/h (bir soatda 80 kilometr)	80 km/soat
80%	80 %

#### 14. Jadvalni to'ldiring.

Soat	Minut	Sekund
		360 s
		3000 s
	145 min	
	45 min	
0,75 h		
1,5 h		

Gektar	Sotix	m <sup>2</sup>
		125 m <sup>2</sup>
		1500 m <sup>2</sup>
1,01 ha		
	60 ar	
	15 ar	
0,5 ha		



#### Mustaqil ish: 15.

#### 15. Bo'sh joylarni to'ldiring.

$0,61 \text{ cm} = \_\_ \text{ m}$

$0,10 \text{ g} = \_\_ \text{ kg}$

$1,4 \text{ m} = \_\_ \text{ km}$

$0,82 \text{ g} = \_\_ \text{ kg}$

$0,31 \text{ kg} = \_\_ \text{ g}$

$0,36 \text{ g} = \_\_ \text{ kg}$

$9,3 \text{ g} = \_\_ \text{ kg}$

$8,1 \text{ L} = \_\_ \text{ ml}$

$0,62 \text{ cm} = \_\_ \text{ m}$

$0,69 \text{ kg} = \_\_ \text{ g}$

$0,13 \text{ L} = \_\_ \text{ ml}$

$0,91 \text{ L} = \_\_ \text{ ml}$

$0,37 \text{ mm} = \_\_ \text{ km}$

$0,36 \text{ km} = \_\_ \text{ cm}$

$0,91 \text{ cm} = \_\_ \text{ km}$

$0,67 \text{ L} = \_\_ \text{ ml}$

$0,98 \text{ kg} = \_\_ \text{ g}$

$0,56 \text{ cm} = \_\_ \text{ mm}$



#### Bu qiziq!

Xalqaro o'lchovlar	Imperator tizimi
U mos ravishda uzunlik, massa va vaqtni o'lchash birliklari sifatida metr, kilogramm va minutga asoslangan.	Bu AQSh, Myanma, Liberiya va boshqa mamlakatlarda qo'llaniladigan o'lchov tizimi bo'lib, dyuym, fut, funt va shu kabi birliklarni o'z ichiga oladi.
Xalqaro birliklar 10 ga karralidir. Masalan, 1 metrda 100 santimetr, 1 kg da 1000 gramm va hokazo.	Imperator birliklarida o'ziga xos ketma-ketlik yo'q.
Xalqaro o'lchov birliklari: santimetr, metr, gramm, litr va boshqalar.	Imperator birliklari: dyuym, fut, unsiya, funt, milya va boshqalar.

# VII bob

## NISBAT, PROPORSIYA VA FOIZ

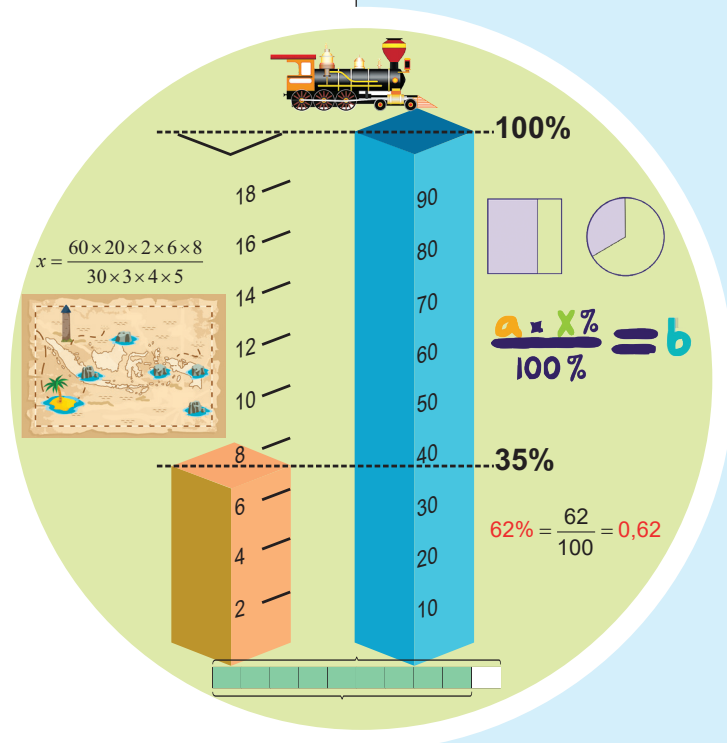



Qaysi transport vositasining tezligi ikkinchisiga nisbatan yuqoriroq?

Yengil avtomobil 220 km/h,



velosiped esa 22 km/h tezlik bilan harakatlanmoqda.



Ikki miqdorni taqqoslash uchun “teng”, “katta”, “kichik” kabi munosabatlar bilan birga “nisbat” tushunchasidan ham foydalaniladi.

$a$ ,  $b$  miqdorlarning nisbati deb  $a : b$  bo‘linmaga aytiladi va “ $a$  ning  $b$  ga nisbati” deb o‘qiladi.



#### Guruhlarda ishlaymiz: 1–4.

1. Ko‘k doiralar sonining qizil oltiburchaklar soniga nisbatini toping.

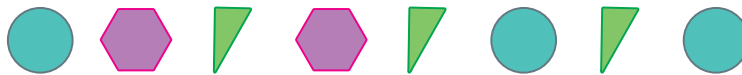

Ko‘k doiralar soni:  $a = 3$

Qizil oltiburchaklar soni:  $b = 2$

Ko‘k doiralar sonining qizil oltiburchaklar soniga nisbati  $3 : 2$ .



Agar  $a$  ning  $b$  ga nisbati 1 dan katta bo‘lsa, u holda  $a : b$  nisbat  $a$  soni  $b$  sonidan *necha marta katta* ekanini anglatadi.

Agar  $a$  ning  $b$  ga nisbati 1 dan kichik bo‘lsa, u holda  $a : b$  nisbat  $a$  soni  $b$  sonining *qanday qismini tashkil etishini* anglatadi.

2. Rasmda 3 ta olma va 7 ta apelsin bor. To‘g‘ri javobni belgilang.



- a) Olmalar sonining apelsinlar soniga nisbati  $3 : 7$  ga teng.  
 b) Apelsinlar sonining olmalar soniga nisbati  $3 : 7$  ga teng.  
 c) Olmalar sonining mevalar umumiy soniga nisbati  $7 : 10$  ga teng.

3. Qopda 19 ta shar bor, ulardan 7 tasi ko‘k, 3 tasi qizil, qolganlari esa yashil rangda.

- a) Ko‘k sharlar sonining jami sharlar soniga nisbatini toping.  
 b) Qizil sharlar sonining ko‘k sharlar soniga nisbatini toping.  
 c) Yashil sharlar sonining jami sharlar soniga nisbatini toping.  
 d) Ko‘k sharlar sonining yashil sharlar soniga nisbatini toping.



4. Tikuvchida 6 ta ko'k, 4 ta sariq va 5 ta yashil tugma bor. Tikuvchida qanday nisbatda tugmalar bor? To'g'ri javobni belgilang.

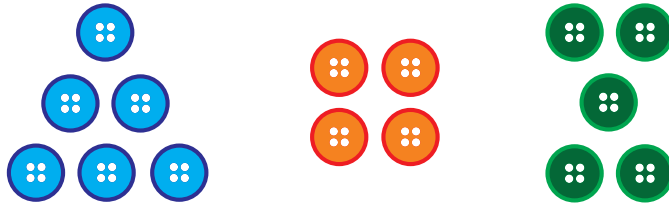

- a) Ko'k tugmalar sonining sariq tugmalar va yashil tugmalar soniga nisbati 6 : 4 : 5.  
b) Yashil tugmalar sonining sariq tugmalar va umumiy tugmalar soniga nisbati 5 : 4 : 15.



### Mustahkamlash: 5–17.

5. Toping:

- a) Yashil uchburchaklar sonini siyohrang oltiburchaklar soniga nisbatini.



- b) Siyohrang oltiburchaklar sonini yashil kvadratlar soniga nisbatini.



$a : b$  nisbatni  $\frac{a}{b}$  kasr ko'rinishida yozish ham mumkin.

6. Avgust oyida libos do'koni 460 ta ko'ylak sotdi, qora va oq rangli ko'ylaklar soni nisbati 3 : 7. Nechta oq rangli ko'ylaklar sotilgan?
7. Sug'urta kompaniyasining 595 ta mijoz bor. Oddiy mijozlarning imtiyozli mijozlar soniga nisbati 8 : 9 ni tashkil etadi. Kompaniyaning necha nafar oddiy mijoz bor?
8. Murod o'zi yoqtirgan va yoqtirmagan qo'shiqlari nisbati 5 : 2 ekanini bildi. Agar u jami 91 ta qo'shiqni tinglagan bo'lsa, unga nechta qo'shiq yoqdi?
9. Supermarketda erkak va ayollar sonining nisbati 4 : 5 edi. U yerda jami 180 kishi bo'lsa, necha nafar erkak bor?
10. Qopda 39 ta shar bor, ulardan 1 tasi ko'k, 6 tasi qizil va qolganlari yashil rangda. Ko'k sharlarning yashil sharlarga nisbatini toping.
11. Raqs to'garagi guruhi 39 nafar a'zodan iborat bo'lib, ulardan 1 nafari o'g'il bola, qolgani qizlar. Qizlarning o'g'il bolalarga nisbatini toping.
12. Pomidor va qizil olmalar 2 : 5 nisbatda. Agar pomidorlar soni 20 ta bo'lsa, qizil olmalar nechta?

4 : 12 nisbatning eng oddiy shaklini toping.



4 : 12 = 2 : 6 = 1 : 3 – ekvivalent nisbatlar.

1 : 3 nisbat 4 : 12 nisbatning eng oddiy shakli.

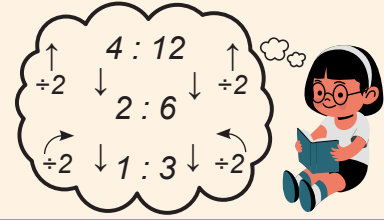

**13.** Har bir nisbatni  $n : 1$  nisbatga keltiring.

a) 20 : 5

b) 15 : 3

c) 100 : 25

d) 34 : 17

**14.** Har bir nisbatni  $1 : n$  nisbatga keltiring.

a) 3 : 24

b) 40 : 160

c) 11 : 770

d) 144 : 6

**15.** Bananlar va qovunlar nisbati 30 : 1. Agar bananlar 300 ta bo'lsa, nechta qovun bor?

**16.** O'yin payti shaxmat taxtasidagi umumiy donalar soniga nisbatan oq va qora donalar 2 : 3 nisbatda qoldi. Oqlar ko'pmi yoki qoralar?

**17.** Usta 2 ta shogirdi bilan ishlab, 100 000 so'mlik ish bajardi. Bu pul shogirdlar va usta orasida 2 : 3 : 5 nisbatda bo'lindi. Har biri qanchadan pul olgan?



### Mustaqil ish: 18.

**18.** Yirik kompaniya katta tadbir o'tkazmoqchi. Kompaniya xodimlar haqida statistik ma'lumotlarni to'plashi kerak.

1-savol. Erkak va ayol xodimlar nisbati 1 : 3. Kompaniyada jami 144 nafar ayol ishlasa, erkaklar soni nechta?

2-savol. 30 nafar xodimning bolalari maktabda o'qiydi, 10 nafar xodimning esa umuman farzandi yo'q. Qolgan ishchilarning farzandlari bog'chaga boradi. Bog'cha yoshidagi bolalari bor xodimlarning farzandi bo'lmagan xodimlarga nisbati qanday?

3-savol. 45 nafar xodim faxriy yorliq, 9 nafar xodim esa pul mukofoti bilan taqdirlandi. Faxriy yorliq olganlar va pul mukofoti bilan taqdirlanganlarning nisbati qancha?

4-savol. 10 nafar xodim suyuq ovqatga, 25 nafar xodim esa quyuq ovqatga buyurtma berdi. Ularning nisbatini toping.

5-savol. Oq mashinasi bor xodimlarning qora mashinasi bor xodimlarga nisbati 5 : 1 ni tashkil qiladi. Agar 10 nafar xodimning oq mashinasi bo'lsa, nechta xodimning qora mashinasi bor?

6-savol. Musiqa asboblari chaluvchi xodimlarning sport bilan shug'ullanuvchi xodimlarga nisbati 3 : 20. Agar 40 nafar xodim sport bilan shug'ullansa, nechta xodim cholg'u asboblari chalishni biladi?

## PROPORSIYALAR. PROPORSIYANING ASOSIY XOSSASI



### Eslaymiz!

1 litrli sut tarkibida 25 g yog' bor.

2 litrli sut tarkibida 50 g yog' bor.

Ayting-chi, qaysi biridan sotib olgan ma'qulroq?



1 : 25 va 2 : 50 nisbatlarni tuzish mumkin.

E'tibor bering, ikkala holatda ham nisbatlar qiymati teng:  $1 : 25 = 2 : 50 = 0,04$

Ular ikkita teng nisbatlar –  $1 : 25 = 2 : 50$

Ikki nisbatning tengligi **proporsiya** deyiladi.

Harflar yordamida proporsiyani quyidagicha yozish mumkin:

$$\frac{a}{b} = \frac{c}{d} \text{ yoki } a : b = c : d$$

O'qilishi: "**a** ning **b** ga nisbati **c** ning **d** ga nisbatiga teng".

Proporsiyada ishtirok etuvchi sonlar **proporsiya hadlari** deb ataladi.

Barcha hadlar nolga teng emas deb hisoblanadi.

$$a \neq 0; b \neq 0; c \neq 0; d \neq 0$$



### Guruhlarda ishlaymiz: 1–5.

1. To'g'ri nisbatlarni toping.

a)  $4 : 7 = 12 : 21$

b)  $5 : 7 = 20 : 21$

c)  $4 : 2,1 = 8 : 4,2$

d)  $1,5 : 10 = 4,5 : 30$

2. Qaysi nisbatlar proporsiya tashkil qiladi?

a)  $26 : 52$  va  $39 : 78$

b)  $105 : 3$  va  $315 : 9$

c)  $7,5 : 2,5$  va  $2,5 : 1,5$

d)  $1 : 2$  va  $1,6 : 3,2$



Teng kasrlar juftligi ham proporsiyani tashkil qiladi.

$$\frac{2}{3} = \frac{4}{6} \quad \frac{8}{9} = \frac{16}{18}$$

3. Nisbatlar proporsiyani hosil qiladimi?

a)  $\frac{4}{2}$  va  $\frac{20}{6}$

b)  $\frac{3}{2}$  va  $\frac{18}{0}$

c)  $\frac{4}{3}$  va  $\frac{16}{12}$

d)  $\frac{4}{3}$  va  $\frac{8}{6}$

### Proporsiyalarning asosiy xossasi

o'rta hadlar

$$a : b = c : d$$

chetki hadlar

$$\iff a \times d = b \times c \iff$$

Proporsiyaning chetki hadlari ko'paytmasi uning o'rta hadlari ko'paytmasiga teng.

#### 4. Proporsiyani tekshiring.

a)  $9 : 3 = 24 : 8$

b)  $0,12 : 0,01 = 3,6 : 0,3$

c)  $1,5 : 3 = 2 : 4$

d)  $50 : 10 = \frac{1}{2} : \frac{1}{10}$

e)  $16 : 4 = 0,4 : 0,1$

f)  $\frac{2}{3} : \frac{4}{9} = 6 : 9$

#### 5. Nisbatni qisqartiring. Hosil bo'lgan proporsiyaning chetki va o'rta hadlarini ayting.

a)  $6 : 10$

b)  $9 : 15$

c)  $7 : 35$

d)  $10 : 28$

e)  $7 : 7$

**Namuna.**  $6 : 10$  nisbatni kasr ko'rinishida yozing va qisqartiring.

$$6 : 10 = \frac{6}{10} = \frac{3}{5} = 3 : 5, \quad 6 \text{ va } 5 \text{ chetki, } 10 \text{ va } 3 \text{ esa o'rta hadlar.}$$



#### Mustahkamlash: 6–12.

#### 6. Supermarketda kir yuvish kukuni quyida ko'rsatilgandek 3 xil paketda sotiladi.

a) B paketi massasini C paketi massasining bir qismi sifatida ifodalang.

b) C ning massasi A ning massasidan necha marta og'irroq?

c) B ning massasini A ning massasiga nisbatini kasr ko'rinishida ifodalang.



#### 7. Proporsiyaning noma'lum hadini toping.

a)  $3x : 6 = 54 : 72$

b)  $12 : x = 8 : 11$

c)  $\frac{x+3}{24} = \frac{3}{4}$

d)  $\frac{5}{6} = \frac{x-7}{10}$

#### 8. Proporsiyaning o'rta hadlari 36 va 4 ga, chetki hadlarining biri esa 18 ga teng. Proporsiyaning ikkinchi chetki hadini toping.

#### 9. Noma'lum vaqtni toping.

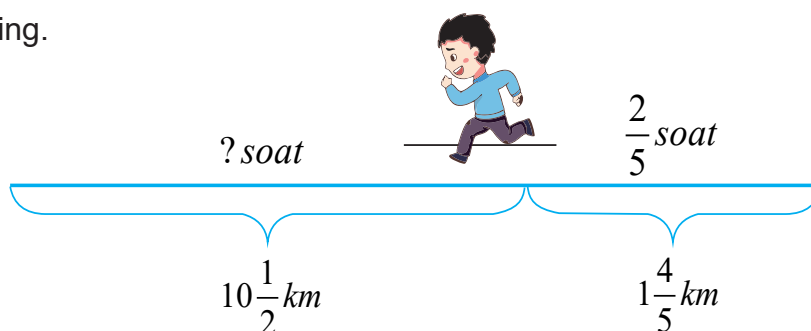

10. Proporsiyaning chetki hadlari 48 va 3 ga, o'rtada hadlarining biri esa 12 ga teng. Proporsiyaning ikkinchi o'rtada hadini toping.
11. Sayohatchilar guruhidagi erkaklarning ayollar soniga nisbati 5 : 2 ni tashkil qiladi. 70, 48, 19, 84, 28 sonlaridan qaysilari guruhdagi sayohatchilar soniga teng bo'la olmaydi?
12. 100 m<sup>3</sup> havoda 21 m<sup>3</sup> kislorod bor. Eni 8 m, bo'yi 10 m va balandligi 3,25 m bo'lgan xonadagi kislorod hajmini toping.



### Mustaqil ish: 13–14.

13. Ravshan va Farhod pullarini taqqoslashganda ularning nisbati 5 : 3 edi. So'ng Ravshan 1,6 mln so'mga planshet sotib oldi. Endi ularning pullari nisbati 3 : 5 bo'ldi. Planshet sotib olishdan oldin Ravshanda qancha pul bor edi?
14. Benzin o'lchagich ko'rsatkichiga ko'ra bakning qancha qismi benzin bilan to'lganini ko'rsatadi? Agar qizil ko'rsatkich 0 ni ko'rsatsa, bak bo'sh, 1 ni ko'rsatsa, bak to'la bo'ladi. Avtomobilning benzin o'lchagichi teng qismlarga bo'lingan. To'liq bakka 64 L benzin sig'adi. Benzin o'lchagichga ko'ra, bakni to'ldirish uchun yana necha litr benzin kerak bo'ladi?

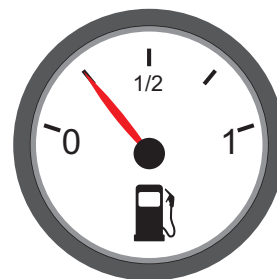

## PROPORSIYANING ASOSIY XOSSASI TATBIQLARI

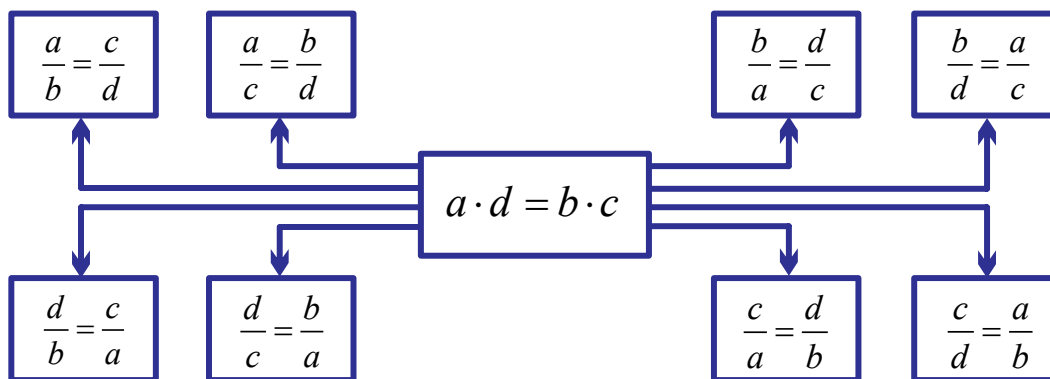

### Guruhlarda ishlaymiz: 1.

1. **Sonni berilgan nisbatda bo'lish**  
Podshoh tojining og'irligi 980 g bo'lib, oltin va platinadan yasalgan. Tojda oltin va platina massalari nisbati 4 : 3 ga teng. Tojni yasash uchun qancha oltin va qancha platina ishlatilgan?



Mos diagramma tuzib yeching:

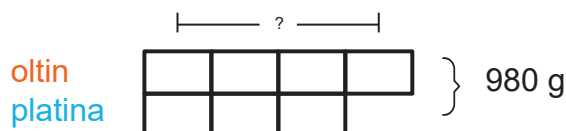

To'rtburchaklar soni:  $4 + 3 = 7$  Har bir to'rtburchakka  $\frac{980}{7} = 140$  g mos keladi.

Demak, oltin:  $4 \times 140 = 560$  g, platina:  $3 \times 140 = 420$  g.

Boshqacha aytganda, biz 980 sonini berilgan  $4 : 3$  nisbatda bo'ldik.



### Mustahkamlash: 2–4.

2. Sonlarni berilgan nisbatda bo'ling.

- a) 48 ni  $3 : 5$       b) 100 ni  $7 : 3$       c) 56 ni  $1 : 6$       d) 50 ni  $4 : 1$   
 e) 120 ni  $5 : 3$       f) 75 ni  $8 : 7$       g) 90 ni  $4 : 5$       h) 120 ni  $40 : 20$

3. Xonadagi erkaklar sonining ayollar soniga nisbati  $4 : 5$ . Dastlab xonaga 2 erkak kirdi va 3 nafar ayol xonadan chiqib ketdi. Keyin xonadagi ayollar soni 2 barobar oshdi. Hozir xonada 18 nafar erkak bo'lsa, ayollar soni nechta?

4. Osh tayyorlashda 1 kg guruchga 1 kg sabzi solinadi. Solinadigan guruchga nisbatan go'sht 2 marta kam, yog' 4 marta kam, piyoz esa 8 marta kam ishlatiladi.

**1-SAVOL.** Oshpazlar to'yga 20 kg guruchdan osh tayyorlash uchun masalliqar ro'yxatini tuzishdi. Ayting-chi, sabzi, go'sht, yog' va piyozning har biridan necha kilogramm sotib olish kerak bo'ladi?

**2-SAVOL.** Tadbirlarda oshpazlar osh pishiriladigan qozonlarni pudlarda o'lchashadi. 1 pud taxminan 16 kilogrammga teng bo'lsa, 1 pud osh tayyorlash uchun qancha masalliq kerak bo'ladi?

**3-SAVOL.** Hisoblab ko'ring-chi, agar 1 kg guruchdan tayyorlangan 2 tovoq osh 4 kishiga yetsa, 1 pud oshga necha kishini taklif qilsa bo'ladi?



### Guruhlarda ishlaymiz: 5.

5. **Abu Rayhon Beruniy masalasi.** G'ishtning o'lchamlari 5, 4, 3 uzunlik birligiga teng. Bunday g'ishtning 30 tasi narxi 60 dirham. O'lchamlari 8, 6, 2 uzunlik birligiga teng 20 ta g'ishtning narxi necha dirham bo'ladi?

$$\frac{60}{x} = \frac{30}{20} \times \frac{3}{2} \times \frac{4}{6} \times \frac{5}{8}$$

Bu tenglamada noma'lum  $x$  topiladi:  $x = \frac{60 \times 20 \times 2 \times 6 \times 8}{30 \times 3 \times 4 \times 5}$ ,  
 bundan  $x = 64$  dirham.

Masalaning bunday sodda va nafis yechilishi Beruniyga mansub. Bu yechim olimning "Hind rashiklari haqida kitob"ida berilgan.

5	8
4	6
3	2
30	20
60	$x$

## Tarixiy ma'lumot



**Abu Rayhon Muhammad ibn Ahmad al-Beruniy** Yerning kattaligini o'lchashda yangi usul qo'llab, bir gradus meridian yoyining uzunligi 111,16 kilometr ekanini hisoblab chiqqan. Beruniy Yerning radiusini o'sha davr uchun aniq o'lchab bergan. U Yerning meridian aylanasi uzunligi 40 183 kilometr ekanini hisoblab chiqqan.

Yer aylanasining uzunligini topish haqida Beruniy bunday deydi: "Yer aylanasining uzunligini topish uchun hamma hollarda ham shu topilgan topilmani, ya'ni radiusni ikkilantirib, 22 ga ko'paytir, hosil bo'lgan ko'paytmani 7 ga bo'l, shunda sen o'lchagan birliklarda Yer aylanasining uzunligi kelib chiqadi". Beruniy aytgan amallarni bajarganda  $3,14... = \pi$  soni kelib chiqadi.



## Mustahkamlash: 6–11.

6. *Abu Rayhon Beruniy masalasi (3 miqdor qoidasi)*. Agar 10 dirham (pul birligi) 2 oyda 5 dirham foyda keltirsa, 8 dirham 3 oyda qancha foyda keltiradi?
7. 3 ta mushuk 16 minutda 6 ta sichqon tutsa, 4 ta mushuk 20 minutda nechta sichqon tutadi?
8. 5 ta otga 30 kunda 9 q yem beriladi. Shu me'yorda yem berilsa, 12 ta otga 18 kunda qancha yem berilishi kerak?
9. 8,5 t yukni 17,5 km masofaga tashish uchun 63 000 so'm to'lanadi. 72 000 so'm berib, qancha yukni 20 km masofaga tashitirish mumkin?
10. Uzunligi 3,6 m, kengligi 1 cm va qalinligi 0,7 cm bo'lgan metall tasmaning massasi 1,98 kg. Xuddi shu metall dan uzunligi 9,6 m, kengligi 2,5 cm, qalinligi 1,4 cm bo'lgan tasma yasalsa, uning massasi necha kg bo'ladi?
11. 54 ta usta 20 qavatli uyni 30 kunda bo'yab bitiradi. 27 qavat uyni 42 kunda bo'yab tugatish uchun nechta usta kerak?



## Mustaqil ish: 13–14.

13. Binoda 9 ta lampochka har kuni 5 soat yonib turadi. Sarflangan elektr uchun 24 kunda 19 444 so'm to'landi. Agar shu binoda 6 ta shunday lampochka har kuni 4 soatdan yonib tursa, 15 120 so'm pul necha kunlik elektr sarfiga yetadi?
14. 1-xonada 60 vattli, 2-xonada 100 vattli, 3-xonada 2 ta 40 vattli va 4-xonada 2 ta 60 vattli lampochkalar bor. Lampochkalar har kuni bir xil muddatda yoniq bo'ladi va 8 kunda sarflanadigan elektr uchun 2 592 so'm to'lanadi. Har bir xonada ko'rsatilgan muddatda necha so'mlik elektr sarflangan?



## Eslaymiz!

Foizlar qanday hisoblangan?

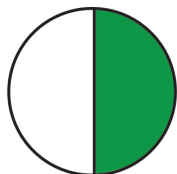

$$\frac{1}{2} = 0,5 = 50\%$$

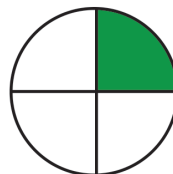

$$\frac{1}{4} = 0,25 = 25\%$$

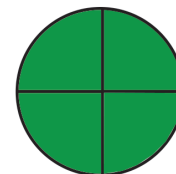

$$\frac{1}{1} = 1 = 100\%$$

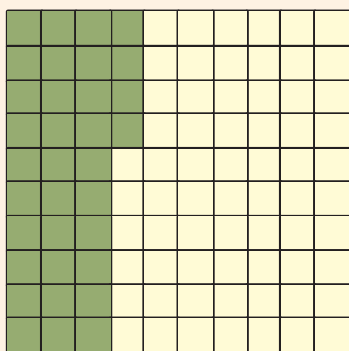

100 ta kvadratdan 34 tasi bo'yalgan.

$$\frac{34}{100} = \frac{34}{100} \times 100 = 34\%$$

Kasrni foiz ko'rinishida ifodalash uchun shu kasrni 100 ga ko'paytirish va natijaga % belgisini qo'yish kifoya.

$$\frac{a}{b} = \frac{a}{b} \times 100 = x\%$$



## Guruhlarda ishlaymiz: 1–3.

1. Namuna asosida bo'yalgan qism butun kvadratning necha foizini tashkil qilishini aniqlaymiz.

*Namuna:* jami 100 katakdan 27 tasi bo'yalgan. Har bir katak kvadratning 100 dan bir qismini, ya'ni 1 foizini tashkil qiladi. Demak, 27 ta katak bo'yalgan bo'lib, bo'yalgan qism butun kvadratning  $\frac{27}{100} = 27\%$  ini tashkil qiladi.

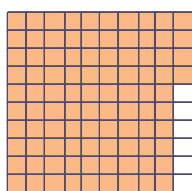
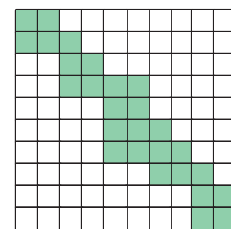

a)

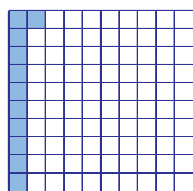

b)

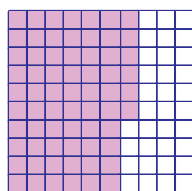

c)

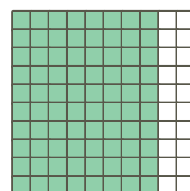

d)

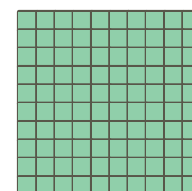

e)

2. Bo'sh kataklarni to'ldiring.

a)  $\frac{3}{4} = \frac{3}{4} \times 100 = \square\%$

b)  $\frac{9}{10} = \frac{\square}{10} \times \square = \square\%$

c)  $\frac{8}{25} = \frac{8}{25} \times \square = \square\%$

d)  $\frac{17}{20} = \frac{\square}{\square} \times \square = \square\%$



Foizni sonda ifodalash uchun berilgan foizni 100 ga bo'lish kifoya:

$$25\% = \frac{25}{100} = \frac{1}{4} = 0,25$$

$$62\% = \frac{62}{100} = 0,62$$

3. Bo'sh kataklarni to'ldiring.

a)  $16\% = \frac{16}{100} = \square$

b)  $7\% = \frac{\square}{100} = \square$

c)  $28\% = \frac{\square}{\square} = \square$

d)  $78\% = \frac{78}{100} = \square$

e)  $85\% = \frac{\square}{100} = \square$

f)  $56\% = \frac{\square}{\square} = \square$



### Mustahkamlash: 4–16.

4. Moslarini belgilang.

a)  $\frac{17}{100}$     $\frac{7}{100}$     $\frac{71}{100}$     $\frac{70}{100}$

b) 90%   19%   9%   91%

71%   70%   17%   7%

0,09   0,90   0,91   0,19

5. Hovlidagi gullarning 40% i atirgullar. Atirgullar barcha gullarning qanday qismini tashkil qiladi? Javobni qisqarmas kasr ko'rinishida yozing.

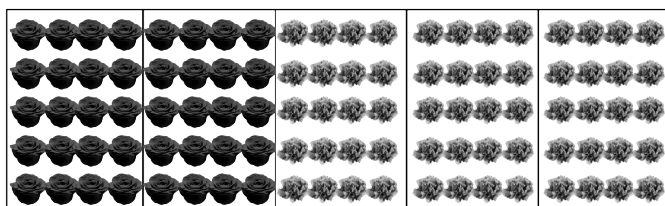

6. Bo'sh joylarni to'ldiring.

$7\% = \frac{\square}{100}$	$1\% = \frac{\square}{100}$
$43\% = \frac{\square}{100}$	$99\% = \frac{\square}{100}$
$14\% = \frac{14}{\square}$	$68\% = \frac{68}{\square}$
$5\% = \frac{5}{\square}$	$84\% = \frac{84}{\square}$

7.  $10 \times 10$  katakli kvadratni qog'ozga chizib, mos qismni bo'yang.

12%      25%      50%      99%      120%      200%

8. Kasr ko'rinishida ifodalang.

- a) 10%      b) 80%      c) 25%      d) 75%      e) 135%
- f) 8%      g) 4%      h) 2%      i) 150%      j) 350%

9. Jahongir jami pulining  $\frac{4}{10}$  qismini tushlik uchun sarfladi. U tushlik uchun jami pulning necha foizini sarflagan?

10. Sonlarni foizlarda ifodalang.

- a) 0,45      b) 0,20      c) 0,99      d) 0,32      e) 0,01  
f) 1,5      g) 1,75      h) 2,5      i) 5      j) 5,5

11. Nasibada 20 ta olma bor, shulardan 14 tasi qizil. Qizil olmalar jami olmalarning necha foizni tashkil etadi?

12. Konsertga borgan 200 nafar o'quvchidan 98 nafari o'g'il bolalar. O'g'il bolalar jami o'quvchilarning necha foizini tashkil etadi?

13. Har bir shkalaning necha foizi bo'yalgan?

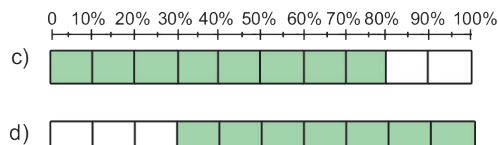
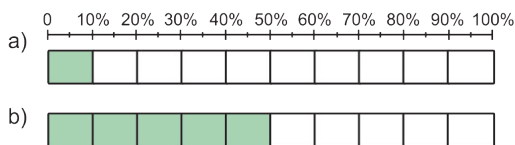

14. Halima xola pishirgan somsalarning  $\frac{3}{4}$  qismi kartoshkali.

- a) Bu necha foizni tashkil qiladi?  
b) Kartoshka qo'shilmagan somsalar necha foizni tashkil qiladi?

15. Sinfdagi o'quvchilar soni 25 nafar bo'lib, ulardan 7 nafari qizlar.

- a) Qizlar necha foizni tashkil qiladi?      b) O'g'il bolalar necha foizni tashkil qiladi?

16. Zamirada 75 000 so'm bor edi. U 30 000 so'mni sarfladi. Uning necha foiz puli qoldi?



### Mustaqil ish: 17–20.

17. Foiz ko'rinishida ifodalang.

- a) 0,63      b) 0,05      c) 0,2      d) 0,5      e) 0,45      f) 0,85

18. Eng sodda kasr ko'rinishida ifodalang.

- a) 46%      b) 5%      c) 7%      d) 80 %

19. O'nli kasr ko'rinishida ifodalang.

- a) 15%      b) 41%      c) 7%      d) 80%

20. Shakllarning necha foizi bo'yalgan?

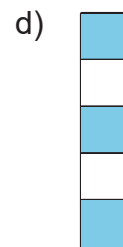
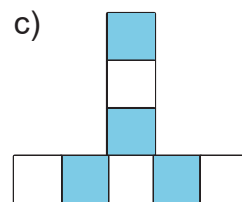
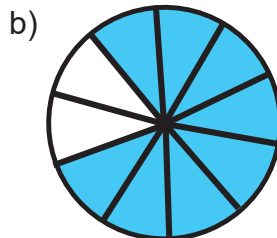
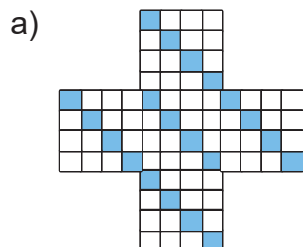

## SONNING FOIZINI VA FOIZIGA KO'RA SONNI TOPISH



$b$  son  $a$  sonning necha foizini tashkil qilishini topish:

$$\frac{b}{a} \times 100\% = x\%$$

60 soni 120 ning necha foizini tashkil qiladi?

$$\frac{60}{120} \times 100\% = 50\%$$



## Guruhlarda ishlaymiz: 1–5.

1. Bo'sh kataklarni to'ldiring.

a) 12 soni 120 ning necha foizi?

$$\frac{12}{120} \times 100\% = \square\%$$

b) 30 soni 150 ning necha foizi?

$$\frac{30}{150} \times \square\% = \square\%$$

2. Berilgan sonlar 500 ning necha foizini tashkil qiladi?

a) 150

b) 250

c) 300

d) 350

e) 450



$a$  sonning  $x$  foizini topish:

$$\frac{a \times x\%}{100\%} = b$$

500 ning 30% i nechaga teng?

$$\frac{500 \times 30\%}{100\%} = 150$$

3. 120 nafar o'quvchidan 90% i test topshirdi. Necha nafar o'quvchi test topshirdi?

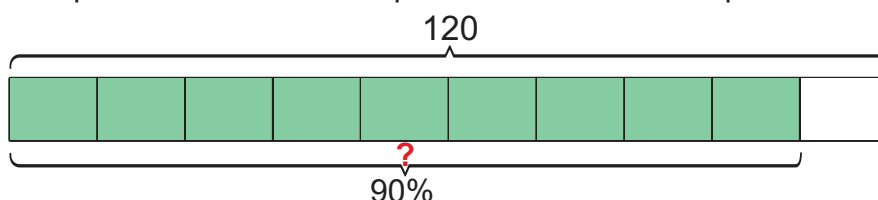

4. Umidjonning oilasi 8 000 000 so'mga muzlatkich sotib oldi. Do'kon ularga 3% chegirma belgiladi. Chegirma necha so'mni tashkil qildi?

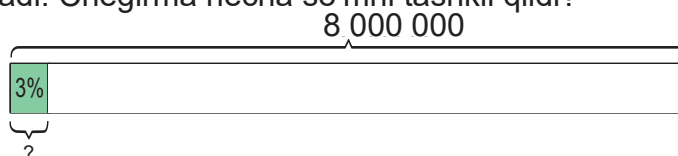

$x$  foizi  $b$  ga teng bo'lgan sonni topish:

$$\frac{b}{x\%} \times 100\% = a$$

70% i 35 ga teng bo'lgan son qaysi?

$$\frac{35}{70\%} \times 100\% = 50$$

5. Korxonadagi 150 nafar ayol jami ishchilarning 30% ini tashkil qiladi. Korxonadagi jami ishchilar soni qancha?

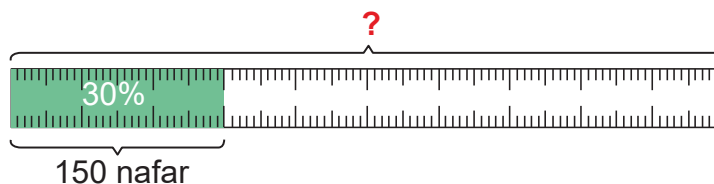

**Mustahkamlash: 6–16.**

6. Qiymatlarni toping.
- a) 300 ning 5% i                      b) 25 ning 5% i                      c) 200 ning 8% i  
d) 50 kg ning 20% i                      e) 70 km ning 45% i                      f) 400 g ning 75% i
7. Zafar 20 ta savoldan 18 tasiga to'g'ri javob berdi. U savollarni necha foizga to'g'ri javob bergan?
8. Marafonda 1 500 kishi ishtirok etdi. Ularning 450 nafari havaskorlar. Qolganlari sportchilar. Ishtirokchilarning necha foizi sportchilar edi?
9. Oqila 5 kg un sotib oldi. U 2 kg unni pechenyega, qolganini ananasli tort tayyorlashga sarfladi. Ananasli tortni tayyorlash uchun unning necha foizi ishlatilgan?
10. Bir qutidagi 100 ta apelsindan 15 tasi yaroqsiz. Apelsinlarning necha foizi yaroqsiz?
11. Avtoturargohda 50 ta avtotransport vositalaridan 14 tasi mototsikl. Bu jami avtotransportlarni necha foizini tashkil qiladi?
12. Qopda 100 ta shar bor. Ulardan 37 tasi yashil rangda. Qolganlari qizil rangda. Sharlarning necha foizi qizil rangda?

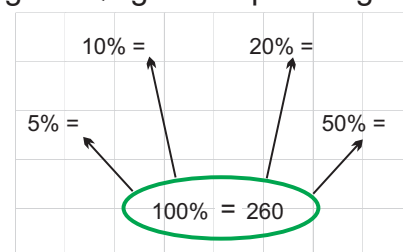

13. Bo'sh o'rinlarni to'ldiring.

14. Agar idishning 70% i suv bilan to'ldirilgan bo'lsa, uning necha foizi bo'sh?

15. Bo'sh kataklarni to'ldiring.

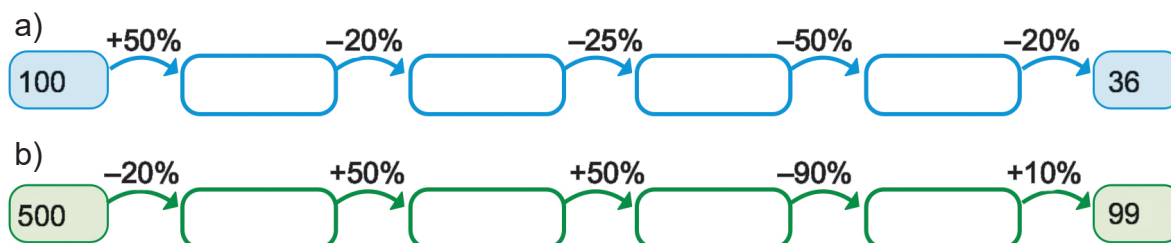

16. Kichik shaharchada 1200 kishi yashaydi. Ularning 45 foizi bolalar. Shaharchada necha nafar bola bor?



### Mustaqil ish: 17–20.

17. Bog'ning maydoni  $60 \text{ m}^2$ . Uning 7 foizini hovuz egallaydi. Hovuzning maydoni qancha?
18. Diktantda 200 ta so'z bor edi. Sanobar ularning 90 foizini to'g'ri yozgan. U nechta so'zni to'g'ri yozgan?
19. Kutubxonada 20 nafar ishchi ishlaydi. Ularning 55 foizini ayollar tashkil etadi. Kutubxonada necha nafar erkak ishchi bor?
20. Savdo do'koni tovarlarga chegirma e'lon qildi. Foizli chegirmadan keyingi narx qanchaga teng bo'ladi?



### FOIZLARNI HISOBLASHGA OID MASALALAR



### Guruhlarda ishlaymiz: 1.

1. Shakllarning taxminan necha foizi bo'yalgan? Javobni eng yaqin 10% gacha aniqlikda yaxlitlang.

1) Deyarli  $\frac{3}{4}$  qismi, taxminan necha foizi bo'yalgan?

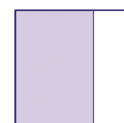

2) Deyarli  $\frac{1}{3}$  qismi, taxminan necha foizi bo'yalgan?



3) Deyarli  $\frac{1}{4}$  qismi, taxminan necha foizi bo'yalgan?

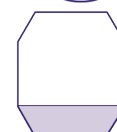

4) Birinchi kvadrat to'liq, ikkinchi kvadratda esa deyarli  $\frac{2}{10}$  qismi, ya'ni taxminan jami necha foizi bo'yalgan?

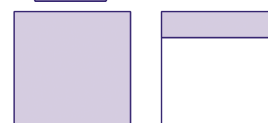

Foizlarni hisoblashda proporsiyadan foydalanish:

800 ming so'mning 25% i necha so'm bo'ladi?

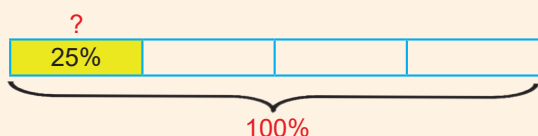

$$800\,000 \text{ so'm} \rightarrow 100\%$$

$$x \text{ so'm} \rightarrow 25\%$$

$$800\,000 \times 25 = 100 \times x$$

$$x = (25 \times 800\,000) \div 100 = 200\,000 \text{ so'm}$$



### Mustahkamlash: 2–13.

2. Kichik qalam katta qalamning necha foizini tashkil qiladi? Chizg'ichdan foydalaning.

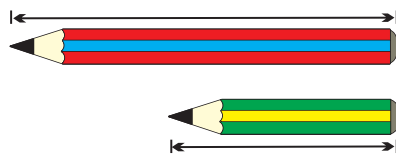

3. Shakllarning taxminan necha foizi bo'yalgan? Javobni eng yaqin 10% gacha aniqlikda yaxlitlang.

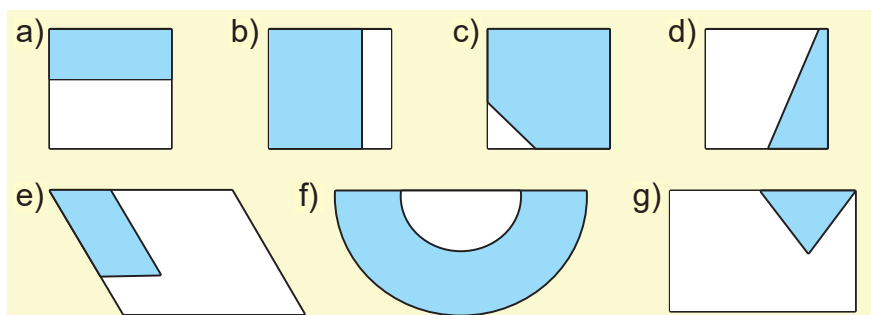

4. Idishlarning necha foizi to'ldirilgan? Javobni eng yaqin 10% gacha aniqlikda yaxlitlang.

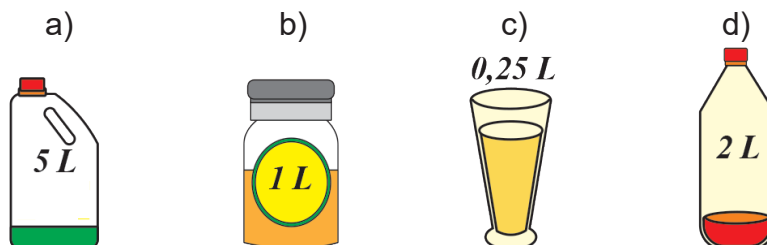

5. Shakllarning taxminan necha foizi bo'yalgan? Javobni eng yaqin 10% gacha aniqlikda yaxlitlang.

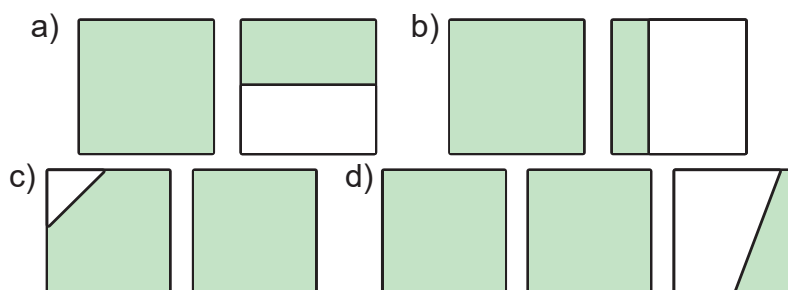

- 6\*. Son 10% ga, keyin natija yana 10% ga oshirildi. Son jami necha foizga oshirildi?

- 7\*. Son 10% ga oshirildi, natija 10% ga kamaydi. Son necha foizga o'zgardi?

8. Vali gazetadan so'nggi 3 oy ichida oziq-ovqat narxi oyiga o'rtacha 10% ga oshganini o'qidi. 3 oy ichida narxlar qanchaga oshdi?

9. Model asosida noma'lumni toping.

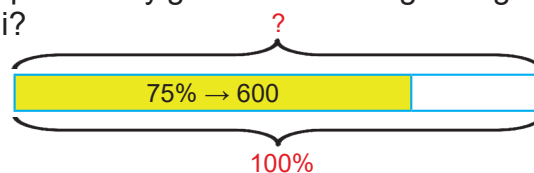

10. 10% li tuzli eritma uchun 600 g suv ishlatiladi, 15% li tuzli eritma uchun necha gramm suv kerak?
11. Tarkibida 20% qand bo'lgan eritma olish uchun tarkibida 30% i shakar bo'lgan 120 g li eritmaga necha gramm suv qo'shish kerak?
12. Tomat pastasini olish uchun pomidor pyuresi massasi maxsus mashinalarda bug'lanadi. Tarkibida 95% suv bo'lgan 28 tonna pyure tomat pastasidan 30% i suv bo'lgan qancha tomat pastasi olinadi?
13. 40 t rudadan tarkibida 6% aralashmalar bo'lgan 20 t metall eritildi. Ruda tarkibidagi aralashmalar necha foizni tashkil qiladi?



### Mustaqil ish: 14–15.

14. Do'konda mahsulotni narxi 10% oshirilgandan so'ng, sotuv hajmi 10% kamaydi. Do'kon mahsulotlarni narxini oshirgandan so'ng foyda ko'radimi, zararmi? Necha foiz?
15. Devorlarning taxminan necha foizi bo'yalmagan? Javobni eng yaqin 10% gacha aniqlikda yaxlitlang.

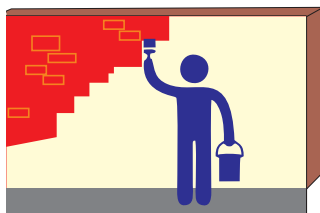

## TO'G'RI VA TESKARI PROPORSIONAL MIQDORLAR



### Eslaymiz!

Kvadratning tomonlari necha martadan oshirilmoqda?

1 cm



2 cm



4 cm



Perimetrlar qanday o'zgaradi?



Agar bir miqdor necha marta ortsa (kamaysa), ikkinchisi ham shuncha marta ortsa (kamaysa), ular **to'g'ri proporsional miqdorlar** deyiladi.

Agar ikkita miqdor to'g'ri proporsional bo'lsa, bu miqdorlarning mos keladigan qiymatlari nisbatlari tengdir.

$a$  va  $b$  to'g'ri proporsional miqdorlar bo'lsa, har doim  $k = \frac{a}{b}$  o'rinli.

$k$  – proporsionallik koeffitsiyenti.  $k$  – natural son yoki kasr son.



### Guruhlarda ishlaymiz: 1–2.

1. 5 metr matoning narxi 120 ming so‘m bo‘lsa, 7 metr matoning narxi necha so‘m bo‘ladi?

Proporsiya tuzamiz:

$$\begin{array}{l} \downarrow 5 \text{ m mato} \quad \text{—} \quad 120 \text{ ming so‘m} \quad \downarrow \\ \downarrow 7 \text{ m mato} \quad \text{—} \quad x \text{ ming so‘m} \quad \downarrow \end{array} \quad \frac{5}{7} = \frac{120}{x} \quad \rightarrow \quad x = \frac{120 \times 7}{5} = 168$$

Javob: 7 m matoning narxi 168 ming so‘m bo‘ladi.



⇓ belgisi miqdorlar to‘g‘ri proporsional bog‘langanini bildiradi.



### Eslaymiz!

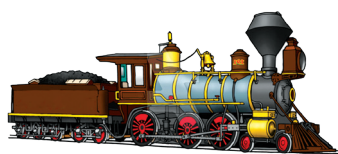

40 km/h

Tezlik bir necha barobar oshirilsa, vaqt shuncha miqdorga kamaydimi?

240 km



60 km/h

240 km



Agar bir miqdor necha marta ortsa (kamaysa), ikkinchisi ham shuncha marta kamaysa (ortsa), ular **teskari proporsional miqdorlar** deyiladi.

Agar ikkita miqdor teskari proporsional bo‘lsa, bu miqdorlarning mos keladigan qiymatlari ko‘paytmalari tengdir.

$a$  va  $b$  teskari proporsional miqdorlar bo‘lsa, har doim  $b = \frac{k}{a}$  o‘rinli.

$k$  – proporsionallik koeffitsiyenti.  $k$  – natural son yoki kasr son.

2. Samolyot 840 km/h tezlik bilan A shahardan B shaharga 7 soatda uchib bordi. Agar samolyotning tezligi 980 km/h bo‘lsa, u A shahardan B shaharga necha soatda uchib boradi?

Proporsiya tuzamiz:

$$\begin{array}{l} \downarrow 840 \text{ km/h} \quad \text{—} \quad 7 \text{ soat} \quad \uparrow \\ \downarrow 980 \text{ km/h} \quad \text{—} \quad x \text{ soat} \quad \uparrow \end{array} \quad \frac{840}{980} = \frac{x}{7} \quad \rightarrow \quad x = \frac{840 \times 7}{980} = 6$$

Javob: 6 soatda uchib boradi.





### Mustahkamlash: 3–10.

3. 135 metr uzunlikdagi simni 6 : 3 nisbatda qismlarga ajrating.
4. 231 sonini 3 : 7 : 11 nisbatda to'g'ri proporsional qismlarga ajrating.
5. Ishchi 2 soatda 100 ta detal tayyorlaydi. Shunday mehnat unumdorligi bilan u 4 soatda nechta detal tayyorlaydi?
6. Qo'yilgan omonat uchun bank yiliga 15% foyda ajratadi. Omonatchi bir yilda 75 000 000 so'm foyda ko'rgan bo'lsa, u bankka necha so'm pul qo'ygan?
7. 5 ta ishchi belgilangan ishni 15 kunda tugatadi. Shu ishni 12 kunda tugatish uchun yana nechta ishchi kerak bo'ladi?



8. Jadvalni to'ldiring.  $v = 10$  km/h

$t, \text{ soat}$	2	4	12
$S, \text{ km}$			

9. 3 ta sonning nisbati 2 : 3 : 8 kabi, yig'indisi esa 67,6 ga teng. Shu sonlarni toping.
10. 100 ta qush 100 kunda 100 kg don yeydi. 10 ta qush 10 kunda necha kg don yeydi?



### Mustaqil ish: 11–13.

11. Uzunligi 35 m, massasi 840 g bo'lgan mis simdan 24,5 m sim qirqib olindi. Qolgan sim bo'lagining massasi qancha?
12. Qadoqlash korxonasi katta idishlarda mahsulotlarni sotib oladi va uni kichik idishlarga qadoqlab, savdoga chiqaradi. Korxonada mahsulotni katta idishlarda sotib olayotganda har kilogrammi uchun 2 000 so'mdan to'laydi, kichik idishlarda savdoga chiqarayotganda esa har bir qadoqdagi mahsulotni 60 000 so'mdan sotadi. Bu hafta korxonada 12 ta katta idishdagi mahsulotlarni sotib olib, qadoqladi va uni 25 ta kichik idishda savdoga chiqardi. Agar katta idishdagi mahsulot miqdori kichik idishdagidan 52 kg og'irroq bo'lsa, korxonada ushbu amaliyotdan qancha foyda ko'rgan?
13. 12 ta ishchi ma'lum miqdordagi ishni 8 soatda bajaradi. Xuddi shu ishni 6 soatda bajarish uchun nechta ishchi kerak?

## TO'G'RI VA TESKARI PROPORSIONAL MIQDORLARNING TATBIQLARI



## Mustahkamlash: 1–11.

1. Maktabda har 5 nafar o'g'il bolaga 4 nafar qiz bola to'g'ri keladi. Maktabda 560 nafar qiz bola bo'lsa, o'g'il bolalar nechta?
2. Beton quyish uchun 1 qop sementga 4 qop qum aralashtiriladi. 100 qop qum uchun necha qop sement ishlatish kerak?
3. Sherning vazni 120 funt. Agar bir funt taxminan 0,45 kilogramm bo'lsa, sherning vazni necha kilogramm?
4. Uch kecha uchun 12 ta chiroq batareyasidan foydalanish mumkin. Yetti kechalik sayohatni rejalashtirish uchun nechta batareya kerak bo'ladi?
5. Hovuzdagi suvni uchta nasos 1 minutda 1 700 L suvni olib tashlashi mumkin. Agar muhandislar 1 minutda kamida 5 500 L ni olib tashlamoqchi bo'lsa, ularga nechta nasos kerak?
6. Antarktidada geologlar har 500 tonna shag'alni elakdan o'tkazib, o'rtacha 7 ta meteorit parchalarini topadi. Xuddi shu bo'laklardan 100 ta olish uchun ular qancha shag'alni elakdan o'tkazishlari kerak?
7. 4 ta pishiriq pishirish uchun 3 ta tuxum kerak. O'nta tuxum bilan nechta pechenye tayyorlashingiz mumkin? 18 ta pechenye uchun nechta tuxum kerak bo'ladi?
8. 8 ta olma 16 000 so'm turadi. Xuddi shunday 18 ta olma necha pul bo'ladi? 64 000 so'mga nechta olma sotib olish mumkin?
9. Eminjon skuterida 50 minutda 18 km yo'lni bosib o'ta oladi. Xuddi shu tezlikda u ikki soatda qancha masofani bosib o'tishi mumkin? U 4 km yo'lni bosib o'tishi uchun qancha vaqt kerak bo'ladi?
10. Grenlandiyadagi Yakobshavn muzligi – dunyodagi eng katta muzlik. U oxirgi besh oy ichida 5,25 kilometr ga kengaydi. Shu sur'atda muzlashda davom etsa, bir yilda qancha masofa muzlaydi?
11. Ahmad xo'jayini bilan bir yillik ish haqi uchun 120 dinor va bitta buzoq olishga kelishdi. U 7 oy ishlaganidan so'ng xo'jayiniga ishdan ketishini aytdi va ish haqini berishini so'radi. Xo'jayini unga 50 dinor va bitta buzoq berdi. Buzoqning narxi necha dinor turadi?



## Mustaqil ish: 12–13.

12. 5 ta pilikli chiroq har kuni 6 soatdan yoqilsa, 24 kunda 120 litr moy sarflanadi. Xuddi shunday 9 ta chiroq har kuni 8 soatdan yoqilsa, 216 litr moy necha kunga yetadi?
13. Yukni 1,5 tonnali 5 ta mashina bilan 6,4 soatda tashish mo'ljallangan. Ikki tonnali 2 ta mashina bilan shu yuk qancha vaqtda tashib bo'linadi?

## MASSHTAB

### Eslaymiz!

Qanday xaritalarni bilasiz?

Minoradan qoyagacha necha santimetr?

Bu masofa necha kilometr bo'lishi mumkin?



**Masshtab** – chizmadagi o'lchamning haqiqiy o'lchamga nisbati.

**Masshtab** – chizmadagi o'lcham haqiqiy o'lchamdan necha marta kichikligini ko'rsatuvchi son.

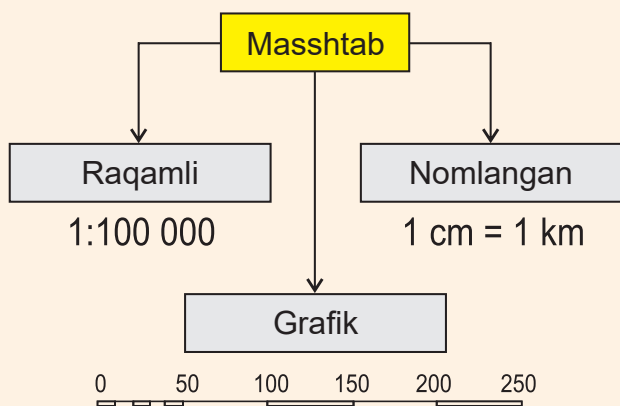

1:100 000 yozuv – chizmadagi o'lchamlarning haqiqiy o'lchamga nisbatini bildiradi.

Chizmadagi 1 cm haqiqiy o'lchamda necha kilometr ekanini aniqlash uchun 100 000 ga ko'paytirish kerakligini bildiradi.

Umuman olganda, xaritada qaysi masshtab berilgan bo'lsa, chizmadagi o'lcham masshtabning o'ng tomonidagi songa ko'paytiriladi.



### Guruhlarda ishlaymiz: 1–2.

1. Agar xarita masshtabi 1:50 000 bo'lsa, xaritadagi 5 cm haqiqiy o'lchamda qancha masofaga to'g'ri keladi?

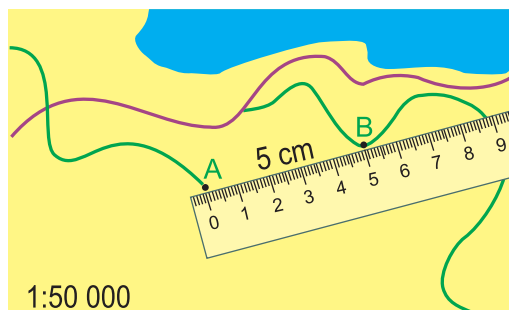

$$\begin{array}{l}
 1 \text{ cm} \text{ ————— } 50\,000 \text{ cm} \\
 \downarrow \qquad \qquad \qquad \downarrow \\
 5 \text{ cm} \text{ ————— } x \text{ cm}
 \end{array}$$

$$x = (5 \times 50\,000) \div 1 = 250\,000 \text{ cm} = 2,5 \text{ km}$$

Javob: xaritadagi 5 cm haqiqiy o'lchamda 2,5 km ga teng.

2. Quyida qirg'oqning chizmasi keltirilgan. Qayiq A nuqtadan yo'lga chiqib, to'g'ri chiziq bo'ylab B nuqtaga boradi. Qayiq bosib o'tgan masofani hisoblang.

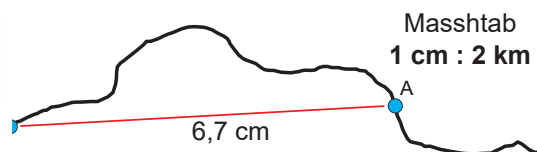

1 cm : 2 km masshtabi bizga xaritada har bir santimetr haqiqiy o'lchamda 2 km ekanini bildiradi.

Katta xatolikka yo'l qo'ymaslik uchun o'lchashni iloji boricha ehtiyotkorlik bilan A va B nuqtalar orasidagi masofani chizg'ich yordamida o'lchaymiz.

Bizning holatda masofa 6,7 cm ekan. Masshtab har bir cm 2 km ekanini bildirishiga asoslanib, qayiq bosib o'tgan haqiqiy masofani toping:

$$6,7 \times 2 = 13,4 \text{ km}$$



### Mustahkamlash: 3–13.

3. Quyidagi chizmada kengligi 10 m bo'lgan uy tasvirlangan. Chizma masshtabini toping.

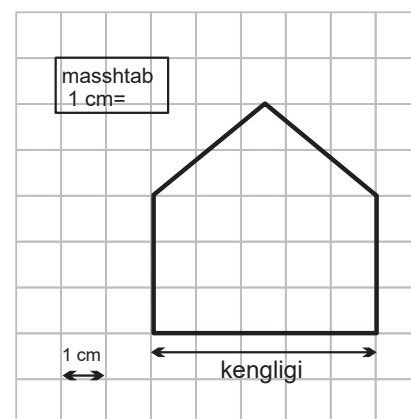

4. Xaritadagi ikki nuqta orasidagi masofa 20 cm. Xarita masshtabi 1:4 000 000 bo'lsa, bu nuqtalar orasidagi haqiqiy o'lchamdagi masofani toping.
5. Ikki shahar orasidagi masofa 230 km. Masshtabi 1:1 000 000 bo'lgan xaritada bu shaharlar orasidagi masofa qanchaga teng bo'ladi?
6. Ikki qishloq orasidagi masofa 32 km. Xaritada bu qishloqlar orasidagi masofa 16 cm. Xarita masshtabini aniqlang.
7. Yer uchastkasi kvadrat shaklda bo'lib, uning yuzi 36 m<sup>2</sup> ga teng. Agar masshtab 1:3 000 bo'lsa, yer uchastkasining chizmasini chizing.
8. Mulohazalarning to'g'riligini tekshiring.
- a) Masshtab: 1:100 000  
 Xaritada 1 mm – haqiqiy o'lchamda 100 m (0,1 km).  
 Xaritada 1 cm – haqiqiy o'lchamda 1 000 m (1 km).  
 Xaritada 10 cm – haqiqiy o'lchamda 10 000 m (10 km).
- b) 1:10000  
 Xaritada 1 mm – haqiqiy o'lchamda 10 m (0,01 km).  
 Xaritada 1 cm – haqiqiy o'lchamda 100 m (0,1 km).  
 Xaritada 10 cm – haqiqiy o'lchamda 1 000 m (1 km).

c) 1:5 000

Xaritada 1 mm – haqiqiy o'lchamda 5 m (0,005 km).

Xaritada 1 cm – haqiqiy o'lchamda 50 m (0,05 km).

Xaritada 10 cm – haqiqiy o'lchamda 500 m (0,5 km).

9. Xaritadagi kesmaning uzunligi 8 cm. Xarita mashtabi 1:10 000 bo'lsa, yerdagi mos masofa uzunligini toping.
10. Ikki shahar orasidagi masofa 400 km. 1:5 000 000 mashtabda tuzilgan xaritada ushbu shaharlarni tutashtiruvchi kesma uzunligini toping.
11. A dan B gacha to'g'ri chiziqdagi masofa uzunligi 700 km. Xaritada 14 cm li kesmani tasvirlash uchun mashtabni qanday belgilash kerak?
12. Xaritada A va B shaharlar orasidagi masofani toping.

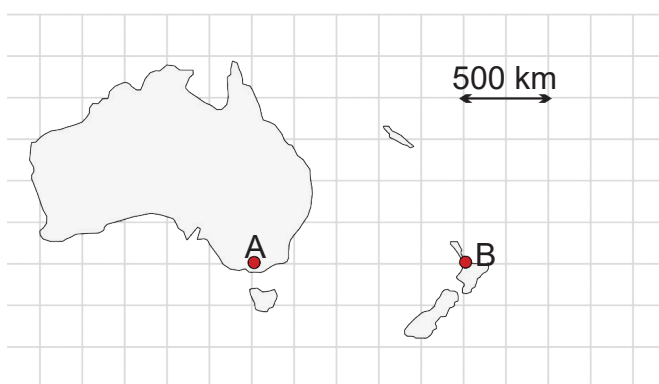

13. 1:10 000 mashtabda chizilgan xaritada Samandar maktabdan uyigacha bo'lgan masofa 15 cm ekanini aniqladi. Samandarning uyidan maktabgacha bo'lgan haqiqiy masofa qancha?



#### Mustaqil ish: 14.

14. **UY-JOY XARIDI.** Quyida Jahongirning ota-onasi ko'chmas mulk agentligidan sotib olmoqchi bo'lgan uyning chizmasi berilgan.

**Savol.** Uy polining umumiy yuzini (devorlar qalinligi va ayvon bilan birgalikda) hisoblash uchun uydagi har bir xonaning yuzi hisoblab chiqiladi. O'lchab chiqilgan barcha xonalar polining yuzlari yig'indisi uyning umumiy maydoni yuziga teng bo'ladi.

Biroq buni hisoblab chiqishning ancha qulay va samarali usuli ham mavjud. Mazkur usulda faqat 4 ta kesma uzunligini o'lchab, ular yordamida uyning umumiy yuzini topish mumkin. Chizmada uyning umumiy maydonini hisoblash uchun kerak bo'ladigan ayni shu 4 ta kesmani belgilang va ular yordamida uyning umumiy yuzini hisoblang.

Mashtab  
1 cm 1 m ni bildiradi

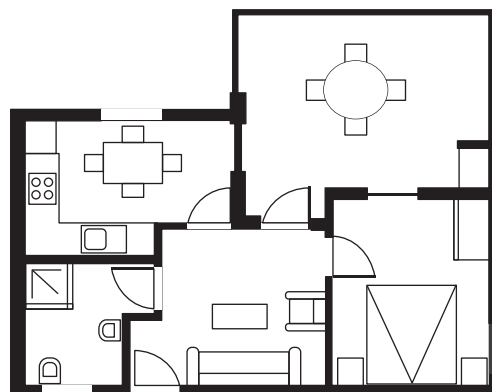

## CHEGIRMALAR MAVSUMI

Chegirmalar mavsumida qator kiyim-kechak do'konlarida 5%, 10%, 20%, 30% li chegirmalar e'lon qilindi.

Mahalliy mahsulotlar	30% – 50%
Xorijiy mahsulotlar	5% – 20%

Chegirma 30 %



100 000 so'm

Chegirma 10 %



250 000 so'm

Chegirma 30 %



80 000 so'm

Chegirma 15 %



120 000 so'm

Chegirma 35 %



110 000 so'm

Chegirma 10 %



200 000 so'm

Lola ko'ylak, sumka, poyabzal xarid qilish niyatida do'konlarni aylandi. O'ziga chegirmalari 30% li ko'ylak, 15% li poyabzal, 10% li sumka tanladi.

**1-savol.** Lola qanday mahsulotlarni tanladi (mahalliy yoki xorijiy)?

Mahsulot	Mahalliy	Xorijiy
Ko'ylak		
Sumka		
Poyabzal		

**2-savol.** Lola jami necha so'mlik xarid qildi? Javobingizni asoslang.

**3-savol.** Agar Lola va singlisi do'konga 1 200 000 so'm bilan borgan bo'lsa, singlisiga yuqoridagi mahsulotlardan qaysilarini xarid qila oladi?

	Poyabzal	Ko'ylak	Sumka
Mahalliy			
Xorijiy			

# VIII bob

## IFODA VA TENGLAMALAR

$\frac{35+37}{2} = \frac{72}{2} = 36$

$\frac{3}{4}$

Jami to'langan pul = Narx × Miqdor

**c** = **p** **n**

$\frac{44+42+37+35+29+29}{6} = \frac{216}{6} = 36$

## SONLI VA HARFIY IFODALAR



Eslaymiz!



Sonlar, arifmetik amallar va qavslardan tuzilgan ifodalar **sonli ifodalar** deb ataladi.

Sonli ifodada berilgan amallar bajarilsa, **sonli ifodaning qiymati** hosil bo'ladi.



$$100 - 1^2 - 2^2 = 95$$

Sonli ifoda

Ifodaning qiymati

Agar sonli ifodalarda harflar ham ishtirok etsa-chi?



$$23 - (a \div c + 45)$$

Harfiy ifoda

$$23 - (40 \div 8 + 45) = 23 - 50 = -17$$

Harfiy ifodaning son qiymati

Harfiy ifodadagi harf o'rniga turli sonlarni qo'yish mumkin.



Guruhlarda ishlaymiz: 1.

1. Ishchi 2 soat ishladi. U birinchi soatda 12 dona, ikkinchi soatda esa birinchi soatdagidan  $m$  dona ko'p detal tayyorladi. Ishchi ikki soatda tayyorlagan detallar sonini ifodalaydigan harfiy ifoda tuzing. Harfiy ifodada  $b$  ning a) 4 ga; b) 8 ga teng bo'lgandagi qiymatini toping.

Harfiy ifoda	$m$	Sonli ifoda	Natija
$12 + (12 + m)$	4	$12 + (12 + \underline{\quad})$	?
$12 + (12 + m)$	8	$12 + (12 + \underline{\quad})$	?



Mustahkamlash: 2–11.

2. Sonli ifodaning qiymatini toping.

a)  $13 \times (-5) + 98$

b)  $127 + 108 \div (-3) - 24$

c)  $12 \times (-8) + 88 \times (-8)$

d)  $13 \times (-88) + 13 \times 88$

e)  $5,5 \times (-23) + 4,5 \times 23$

f)  $0,05 \times (-0,1) + 4,05$



3. Chizma asosida sonli ifodalar tuzing va mos qiymatini toping.

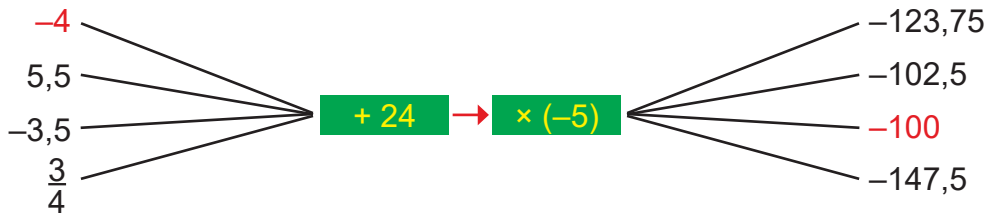

4. Azizada  $n$  ta CD disk bor edi. Unga o'rtog'lari yana 5 ta disk sovg'a qilishdi. Azizada jami qancha disk bo'ldi?
5. Asal  $x$  yoshda, Sobir undan 8 yosh kichik. Sobirning yoshi qancha? Agar Asalning yoshi a) 10; b) 14; d) 16 ga teng bo'lganda, Sobirning yoshi qancha bo'lardi?
6. Harfiy ifodaning qiymatini toping.
- a)  $128 - b$ , bunda  $b = 31; 43; 59$ .                      b)  $b - 18$ , bunda  $b = 39; 124; 215$ .
- c)  $35 + x$ , bunda  $x = 0; 10; 100$ .                      d)  $125 - x$ , bunda  $x = 0; 110; 98$ .
7. Ifodaning qiymati nimaga teng?
- a)  $(128 - 12b) + (14b - 18)$ , bunda  $b = 3; 4; 5$ .
- b)  $(30y - 25) - (20y + 10)$ , bunda  $y = 4; 8; 10$ .

Namuna: a)  $b = 3$  bo'lganda,  $(128 - 12b) + (14b - 18) = (128 - 12 \times 3) + (14 \times 3 - 18) = (128 - 36) + (42 - 18) = 92 + 24 = 116$ .

8. Jadvalni to'ldiring.

Harfiy ifoda	$k$	Sonli ifoda	Natija
$36 + (18 - 2k) \times (-5)$	-13		?
$12 \times (1,2 + k)$	$\frac{-5}{12}$		?

9. Duradgor uch kunda buyurtmani bajardi. U birinchi kuni 24 ta, ikkinchi kuni birinchi kundagidan  $a$  ta ko'p, uchinchi kuni esa ikkinchi kundagidan 4 ta kam stul yasadi.  $a = 8; 10; 12$  qiymatlarda duradgor jami nechta stul yasagan?
10. Chizmadagi uchburchakning perimetri va yuzini  $a = 5,5$  cm,  $b = 12$  cm va  $c = 13$  cm bo'lganda hisoblang.

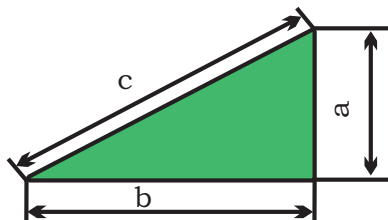

11. Nozima onasi uchun meva sharbati tayyorladi. U mikserga ko'rsatilgan miqdorda apelsin sharbati, undan  $k$  marta ko'p olma sharbatini quydi. Nozima tayyorlamoqchi bo'lgan sharbat necha millilitrga teng bo'ldi? Masala shartiga mos harfiy ifoda tuzamiz va  $k = 6$  bo'lgandagi qiymatini toping.

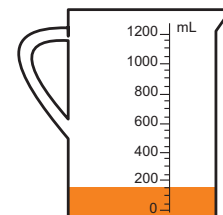



### Mustaqil ish: 12–20.

12. Agar kamayuvchi 4 ga, ayriluvchi esa 16 ga kamaytirilsa, ayirma qanday o'zgaradi?
13. Kamayuvchi 24 ga orttirilsa, ayriluvchi 15 ga kamaytirilsa, ayirma qanday o'zgaradi?
14. Qulay usulda hisoblang.
- a)  $321 \times 1001$                       b)  $478 \times 1\,001$                       c)  $905 \times 1\,001$
15. Qulay usul bilan hisoblang.
- a)  $(4,95 - 2,45) + (3,275 - 4,95)$       b)  $(-3\,321 + 601) - (21 - 9) - (-1\,003)$
- c)  $-(9,75 + 0,25) - (8,05 - 1,3)$       d)  $(6\frac{13}{18} - 4,2) - (2\frac{12}{18} - 1,2)$
16. Quyidagi shaklda har bir katak  $a$  millimetrga teng. Har bir shaklning perimetrini hamda barcha shakllar perimetrining yig'indisini toping. Masala shartiga mos harfiy ifoda tuzing va  $a = 5$  mm da hisoblang.

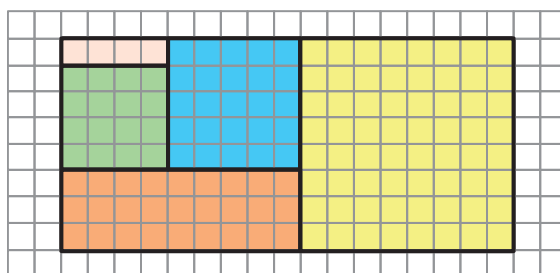

17. Ifodaning qiymatini toping.
- a)  $12a + 51b$ , bunda  $a = 11$  va  $b = 23$       b)  $59p - 23q$ , bunda  $p = 13$  va  $q = 22$
18. Sonli ifodaning qiymatini toping.
- a)  $81 \div 9 + 12 \times 5$       b)  $127 \times 2 + 145 \div 5$       c)  $22 \times 4 + 180 \div 15 + 43$
19. Harfiy ifodaning qiymatini toping.
- a)  $28 - c$ , bunda  $c = 12$ ; 24      b)  $d - 109$ , bunda  $d = 139$ ; 523
20. Chizma asosida harfiy ifoda tuzing va uning  $b = \frac{3}{8}$  bo'lgandagi qiymatini toping.

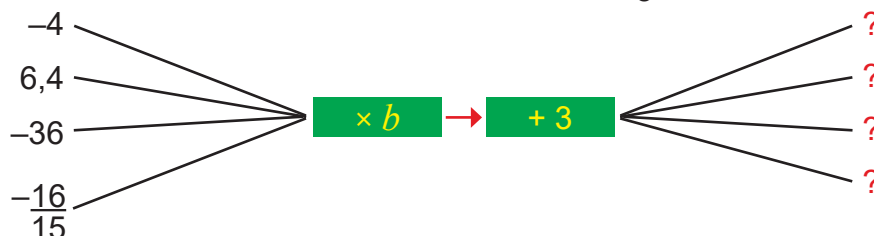

## TENGLIKLAR VA ULARNING XOSSALARI



Eslaymiz!

Hisoblashlar qanday bajariladi?

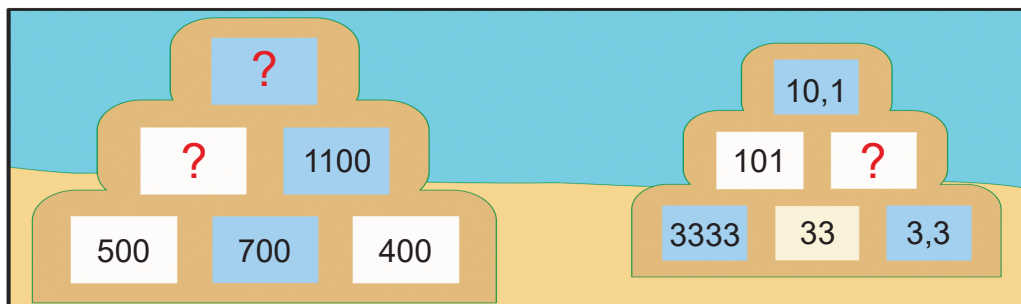

Ifodalarning bunday bog'lanishi qanday ma'noga ega?



$$-47 + 35 = -24 \div 2$$

$$-12 = -12$$

Ikkita sonli ifodalarning "=" belgisi bilan bog'lanishi **tengliklar** deyiladi.Tengliklardagi ifodalarning qiymati o'zaro **teng** bo'ladi.

Guruhlarda ishlaymiz: 1–6.

1. Ifodalarning tengligini tekshiring.

a)  $3 \times 11 = 33$     b)  $48 \div 6 = -8 \div (-1)$     c)  $91 \times 2,08 + 9 \times 2,08 = 2,08 \times (91 + 9)$



$$2 \times 45 + 5 = 90 + 5$$

$$95 = 95$$

Tenglikning ikkala qismiga bir xil son qo'shilsa yoki ayrilsa, tenglik o'zgarmaydi.

$$a + c = b + c$$

$$a = b$$

2. Tengliklarning ikkala qismiga 0,2; -5,5 va 44 ni qo'shing.

a)  $-28 \times 2 = -7 \times 0,8$     b)  $-0,011 \times 10 = 0,88 \div (-8)$



$$2 \times 45 \times 5 = 90 \times 5$$

$$450 = 450$$

Tenglikning ikkala qismi bir xil songa ko'paytirilsa yoki noldan farqli songa bo'linsa, tenglik o'zgarmaydi.

$$a \times c = b \times c$$

$$a \div c = b \div c$$

$$a = b$$

3. Berilgan  $5,4 \times 2 = 10,8$  tenglikning ikkala qismini a) -3; b) 9; c) 6; d) 0,2 sonlariga bo'lib, to'g'ri tenglik hosil qiling.

$$9 \times 4 = 36 \text{ va } 36 = 18 \times 2$$

$$9 \times 4 = 18 \times 2$$

Agar  $a = b$  va  $b = c$  bo'lsa,  
 $a = c$ 

4. Tengliklar to'g'ri bo'lishi uchun bo'sh kataklarni to'ldiring.

a)  $-3 \times \square = -6$  va  $-6 = \square - 4$

b)  $\square \times 5 = -3,3$  va  $-3,3 = \square + 33$

$$-3 \times \square = \square - 4$$

$$\square \times 5 = \square + 33$$



Agar  $a = b$  va  $c = d$  bo'lsa,  
 $a + c = b + d$

$$56 \div (-7) = -8 \text{ va } -12 \times (-5) = 60$$

$$56 \div (-7) + (-12) \times (-5) = -8 + 60$$

$$52 = 52$$

5. Tengliklarni qo'shing.

a)  $-9 \div 1,5 = -6$  va  $4 = 3,2 \div 0,8$

b)  $0,8 \div (-7) = -5,6$  va  $1,2 \times 5 = 6$



Agar  $a = b$  va  $c = d$  bo'lsa,  
 $a \times c = b \times d$

$$19 - 4 = 15 \text{ va } -4 + 13 = 9$$

$$(19 - 4) \times (-4 + 13) = 15 \times 9$$

$$135 = 135$$

6. Tengliklarni hadma-had ko'paytiring.

a)  $-19 + 24 = 5$  va  $54 \div 0,9 = 60$

b)  $3 - 1,4 = 1,6$  va  $6,4 \div 4 = 1,6$



### Mustahkamlash: 7–12.

7. To'g'ri tengliklarni aniqlang.

a)  $6 + 3 = 1,8 \times 5$

b)  $2,8 - 9 = 3,4 \times 2$

c)  $0,9 \times 6 = 10 - 2,6$

d)  $1,6 - 4 = 0,8 \times 2 + 4$

8. Namuna asosida ifodalarning qiymatini toping va natijaga teng tenglik tuzing.

$$101 \times 25 - 101 \times 15 = 101 (25 - 15) = 1\ 010$$

$$1\ 010 = 202 \times 5$$

a)  $81 \times 21 + 19 \times 21$

b)  $252 \times 80 - 252 \times 70$

c)  $201 \times 91 + 112 \times 91$

9.  $x + 12 = 43$  tenglikning ikkala qismiga 4 va  $-5$  ni qo'shing.

10. Katalarni shunday to'ldiringki, natijada to'g'ri tenglik hosil bo'lsin.

a)  $8 - \square = 0,5$

b)  $4,5 - \square = 1,5$

c)  $\square + 3,2 = 1$

d)  $\square \times 2,2 = 11$

e)  $0,4 \times \square = -8$

f)  $\square \div (-99) = 9$

g)  $\square \div (-5) = 45$

h)  $0,001 + \square = 0$

11. Tengliklarni ustun shaklida qo'shing.

a)  $-6 \div 1,5 = -4$  va  $3 = 3,3 \div 1,1$

b)  $8 \div (-2) = -16$  va  $1,5 \times 2 = 3$

c)  $9 \div 0,3 = 30$  va  $0,8 \div 2 = 0,4$

d)  $1,69 \div 0,13 = 13$  va  $-54 \div 2 = -27$

12.  $-10 + 44 = 34$  va  $8,4 \div 2,1 = 4$  tengliklarni hadma-had ko'paytiring.



### Mustaqil ish: 13–18.

13. Berilgan  $-7 + 83 = 76$  tenglikning ikkala qismiga a) 13; b)  $-16$ ; c) 4,3; d)  $\frac{2}{5}$  sonlarini qo'shib, to'g'ri tenglik hosil qiling.

14.  $-5 \times (-4,2) = 21$  tenglikning ikkala qismini 4 va  $-5$  ga ko'paytiring.



**Mustahkamlash: 5–18.**

5. Tenglamalarni yeching.

$$1) 48 + x = 80 - 19$$

$$2) -30 + x = -47 - (-17)$$

$$3) 96 - x = 96 - (-33)$$

$$4) -71 - x = -49 + 21$$

$$5) x + (-19) = -23 - (-19)$$

$$6) -x - (-28) = -21 + 53$$

6. Noma'lum massani toping.

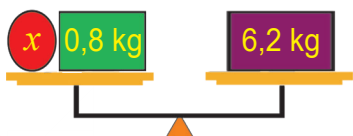

7. Hisoblashning qulay usulini toping.

$$a) 6,96 \times 24 - 6,96 \times 14$$

$$b) 53 \times 17 + 32 \times 17$$

$$c) 23 \times 99 - 23 \times 51$$

8. “?” belgisi o‘rnini to‘ldiring, natijada to‘g‘ri tenglik hosil bo‘lsin.

$$a) 15 - ? = 5$$

$$b) 3,2 - ? = 1$$

$$c) ? + 42 = 17$$

$$d) ? \times 5,2 = 10,4$$

$$e) 0,3 \times ? = -9$$

$$f) ? \div (-11) = 7$$

9. Berilgan  $-15 + 3 = -12$  tenglikning ikkala qismiga a) 7; b)  $-11$ ; c) 3,2 sonlarini qo‘shib, to‘g‘ri tenglik hosil qiling.

10. Yechimi 2 ga,  $-2$  ga, 10 ga va 0,5 ga teng bo‘lgan tenglamalar tuzing.

11. Taxta bo‘laklari necha metrdan?

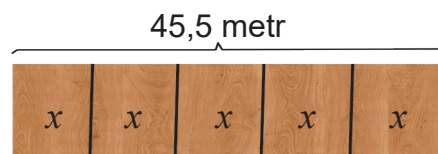
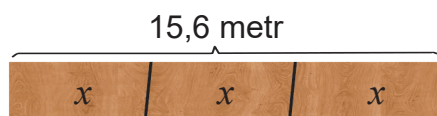

12. Tenglamaning to‘g‘ri yechimini toping.

1	$2x + 3 = -13$	A	4
2	$-4x + 3 = -13$	B	$-2,5$
3	$3,8 - 2x = 40$	C	$-8$
4	$7,3 - 2x = 12,3$	D	$-9$
5	$15x + 121 = -14$	E	$-18,1$
6	$7x = -20 + (-29)$	F	$-7$

13. Yechimi 4 ga,  $-5$  ga, 6 ga va  $0,2$  ga teng bo'lgan tenglamalar tuzing.
14. Biror sonning 20 bilan farqi o'sha sonning 32 bilan farqiga teng. Bu son qaysi?
15. Barnoning mushuklari va jo'jalari soni teng. Barno uy hayvonlarining oyoqlarini sanaganda, jami 48 ta chiqdi. Barnoning nechta jo'jasi bor?
16. Malika va Ra'no archani bezatish uchun qog'ozdan qushchalar yasadi, Malika yasagan qushchalar soni Ra'nonikidan 8 taga ko'proq. Agar qizlar jami 26 ta bezak yasagan bo'lsa, Ra'no yasagan bezaklar sonini toping.
17. Qulupnay juda foydali bo'lib, uning 100 grammida 60 mg C vitamini mavjud. 6-sinf o'quvchisi organizmi uchun 1 sutkada 100 mg C vitamini kerak bo'ladi. Kumushbibi 200 g qulupnayni yeb tugatdi.  
Savol: Kumushbibi shu yegan qulupnayni orqali o'zi uchun kunlik C vitamini miqdorini oladimi?
18. Tenglamani yeching.
- a)  $10 \times x - 4,82 = 12,6$                       b)  $0,394 + 100 \times x = 5$   
 c)  $1,625 - x \div 1000 = 0,98$                 d)  $100 \div x + 8,699 = 8,7$   
 e)  $8,642 - x \div 100 = 7,09$                 f)  $100 \times x - 1,035 = 18,2$



### Mustaqil ish: 19–21.

19. Tenglamani yeching.
- a)  $x - 5,9 = 7,95$                                 b)  $(x - 10,47) + 3,18 = 5,6$   
 c)  $8,1 - x = 3,407$                               d)  $40 - (x - 6,72) = 11,6$
20. Rasmda tasvirlangan ustma-ust qo'yilgan 8 ta tuvakning balandligi 42 cm, 2 ta tuvakning balandligi 18 cm bo'lsa, ustma-ust qo'yilgan 6 ta tuvakning balandligi qancha bo'ladi?

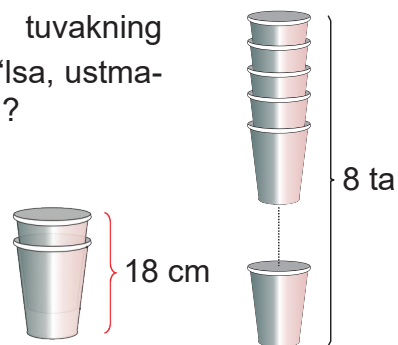

21. Men bir son o'yladim. Agar uni 2 ga ko'paytirib, hosil bo'lgan ko'paytmani 8 ga bo'lib, bo'linmaga 20 ni qo'shib, yig'indidan 15 ni ayirsam, 10 hosil bo'ladi. Men o'ylagan sonni toping.



Jami to'langan pul = Narx × Miqdor

$$c = p \times n$$

Jami to'langan pulni topish uchun tovar narxi xarid qilingan miqdorga ko'paytiriladi.



### Guruhlarda ishlaymiz: 1.

- Masalaning yechish usullarini tahlil qiling va xulosangizni bildiring.  
Oromgohda 342 nafar bola bor. U yerda har bir bola uchun kunda 60 g shakar beriladi. Bir kun bolalarni shakar bilan ta'minlash uchun bir kilogrammlik shakar paketlaridan kamida nechta kerak bo'ladi? Agar shakarning narxi 8300 so'm bo'lsa, bir kunda oromgohda necha so'mlik shakar ishlatiladi?

- Jami necha kilogramm shakar kerak?

$$60 \times 342 = 20\ 520 = 20\ \text{kg}\ 520\ \text{g}$$

$$20\ \text{kg}\ 520\ \text{g} = 20\ 520\ \text{g}$$

$$20\ 520\ \text{g} \div 1000 = 20\ \text{ta paket} + 520\ \text{ham}\ 1\ \text{ta paket bo'lsa,}\ 21\ \text{ta paket.}$$

- Berilgan:

$$n = 21$$

$$p = 8\ 300$$

$$c = ?$$

$$c = p \times n = 8\ 300 \times 21 = 174\ 300\ (\text{so'm})$$



### Mustahkamlash: 2–5.

- Masala shartini to'ldiring va yeching.

Do'konda bir xil bo'yoqdan 3 yoki undan ko'p banka sotib olinsa, sotib olingan har bir banka bo'yoq narxi  $\frac{1}{5}$  qismiga kamaytirilishi e'lon qilindi.

Agar oila ... banka bo'yoq sotib olsa, necha so'm mablag' tejab qoladi?

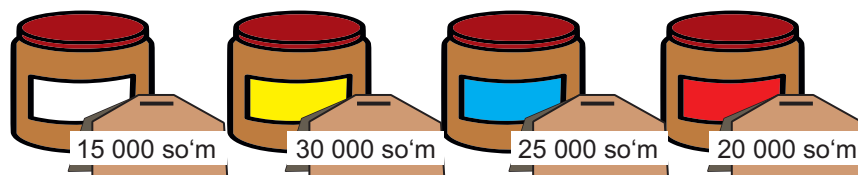

- Maktabda har kuni 600 ta 0,5 litrli suv sotiladi. Suvning narxi 1200 so'm bo'lsa, jami qancha savdo qilinadi? Suv 1500 so'm bo'lsa-chi?





$$\text{Narx} = \text{Jami to'langan pul} \div \text{Miqdor}$$

$$p = c \div n$$

Tovar narxini topish uchun jami to'langan pul tovar miqdoriga bo'linadi.

$$\text{Miqdor} = \text{Jami to'langan pul} \div \text{Narx}$$

$$n = c \div p$$

Tovar miqdorini topish uchun jami to'langan pul tovar narxiga bo'linadi.

#### 4–5. Masalalar yechimini tahlil qilib, xulosangizni bildiring.

12 kg olma uchun jami 72 000 so'm to'landi. Olmaning narxi qancha?

Berilgan:

$$n = 12 \text{ kg}$$

$$c = 72\,000 \text{ so'm}$$

$$p = ?$$

$$p = c \div n = 72\,000 \div 12$$

$$p = 6\,000 \text{ (so'm)}$$

Oromgohda har bir bola uchun kuniga 20 g sariyog' beriladi. Oromgohda 456 ta bola bor. Bir kunda bolalarni sariyog' bilan ta'minlash uchun uch kilogrammik sariyog' bo'laklaridan kamida nechta kerak bo'ladi?

1) Jami necha kilogramm sariyog' kerak?

$$456 \times 20 = 9\,120 \text{ g}$$

2) Berilgan:

$$c = 9\,120$$

$$p = 3\,000$$

$$n = ?$$

$$n = c \div p = 9\,120 \div 3\,000 = 3 \text{ (120 qoldiq)}$$

Demak, kamida 4 bo'lak sariyog' kerak.



#### Mustahkamlash: 6–14.

6. 1 m<sup>2</sup> polni bo'yash uchun 200 g bo'yoq ishlatiladi. Bo'yoq 2 kg li bankalarda sotiladi. Yuzi 64 m<sup>2</sup> bo'lgan polni bo'yash uchun necha banka bo'yoq sotib olish kerak? Bir banka bo'yoq narxi 80 000 so'm bo'lsa, bo'yoq sotib olish uchun qancha mablag' kerak?
7. Do'konda reklama tadbiri o'tkazilmoqda: sotib olingan har ikki dona qadoqlangan choyga uchinchisi sovg'a qilinadi (quyidagi rasm). Qadoqlangan choyning narxi 11 500 so'm. 100 000 so'mga ko'pi bilan necha dona qadoqlangan choy sotib olish mumkin?



11 500 so'm

8. Uyni ta'mirlash uchun 42 o'ram gulqog'oz sotib olindi. Bir quti yelim 8 o'ram gulqog'oz uchun yetadi. Gulqog'ozlarni devorga yopishtirish uchun necha quti yelim sotib olish kerak? Bir o'ram gulqog'oz narxi 70 000 so'm, bir quti yelim narxi 10 000 so'm bo'lsa, uyni ta'mirlash uchun qancha mablag' kerak?

- 9.** Komiljon ota nabiralari uchun bozordan 4 savat qulupnay sotib oldi. Har bir savatda 1,5 kg dan qulupnay bor. Mevalar uchun 120 000 so'm to'landi. Bir kilogramm qulupnay narxi qancha?
- 10.** 1 kilogrammi 12 500 so'm bo'lgan konfetdan bir nechta quti xarid qilindi. Har bir qutiga 3 kg dan konfet joylangan. Xarid uchun 300 000 so'm to'langan bo'lsa, necha quti konfet sotib olingan?
- 11.** Sevara va uning oilasi har kuni nonushtada to'rt stakan choy ichadi va bir stakan choyga ikkita oqqand qo'shadi. Shunga ko'ra, Sevaraning to'rt kishilik oilasi 360 dona oqqandni necha kunda tugatadi?
- 12.** Sayohat uchun ma'lum miqdorda pul yig'ish kerak. Agar har bir sayohatchi 550 so'mdan to'lasa, to'lovga 3 200 so'm yetmaydi, agar har bir sayohatchi 900 so'mdan to'lasa, 5 200 so'm ortib qoladi. Sayohatga necha kishi chiqishi kerak?
- 13.** Korxonadan 40 million so'mni bir yil muddatga yillik 20% stavkasi bilan olgan bo'lsa, bir yildan so'ng korxonada jami qancha miqdorda bankka pul qaytaradi?
- 14.** 3,1 m<sup>2</sup> shiftni bo'yash uchun 150 g bo'yoq ishlatiladi. Bo'yoq 3 kg li bankalarda sotiladi. Yuza 78 m<sup>2</sup> bo'lgan shiftni bo'yash uchun necha banka bo'yoq sotib olish kerak? Bir banka bo'yoq narxi 130 000 so'm bo'lsa, bo'yoq ishlari uchun qancha mablag' kerak?



#### Qiziqarli matematika: 15.

- 15.** Ali bilan Said do'konga shokolad olgani kirdi. Shokolad olish uchun Aliga 24 so'm, Saidga esa 2 so'm yetmayapti. Shokoladning narxi butun sondan iborat. Ali shokoladdan voz kechib, bor pulini Saidga bergan bo'lishiga qaramay, Saidning puli yetmayapti. Shokoladning narxini toping.



#### Mustaqil ish: 16–23.

- 16.** Narxi 35 000 so'm bo'lgan shirinliklar uchun 140 000 so'm to'landi. Necha kilogramm shirinlikka pul to'langan?
- 17.** 70 kg o'rik uchun jami 28 000 so'm to'landi. 1 kg o'rik narxini toping.
- 18.** Sayohat uchun ma'lum miqdorda pul yig'ish kerak. Agar har bir sayohatchi 750 so'mdan to'lasa, to'lovga 1 200 so'm yetmaydi, har bir sayohatchi 800 so'mdan to'lasa, 1 200 so'm ortib qoladi. Sayohatga necha kishi chiqishi kerak?
- 19.** Abbas futbol to'pi sotib olish uchun bir nechta boladan 12 000 so'mdan pul yig'moqchi bo'ldi. Saflariga 2 ta bola kelib qo'shilganidan so'ng, to'p sotib olish uchun har bir bola 10 000 so'mdan berishi yetarli bo'ldi. To'p sotib olish uchun necha bola 12 000 so'mdan pul yig'moqchi bo'lgan?

20. Do'konda reklama tadbiri o'tkazilmoqda: sotib olingan har ikki dona tish pastasiga uchinchi sovg'a qilinadi. Tish pastasining narxi 8500 so'm. 50 000 so'mga ko'pi bilan nechta tish pastasi sotib olish mumkin?
21. Uyni ta'mirlash uchun 38 o'ram gulqog'oz sotib olindi. Bir quti yelim 7 ta o'ram gulqog'oz uchun yetadi. Gulqog'ozlarni devorga yopishtirish uchun necha quti yelim sotib olish kerak? Bir o'ram gulqog'oz narxi 95 000 so'm, bir quti yelim narxi 9 000 so'm bo'lsa, jami mahsulot qancha mablag' kerak bo'ladi?
22. Ali, Vali va Soli har kuni bir stakandan qahva ichadi va bir stakan qahvaga uch donadan oqqand qo'shadi. Shunga ko'ra, ular 450 dona oqqand solingan qutini necha kunda tugatadi?
23. Kamol oshxonada "No'xot sho'rak" taomi uchun 2 kunda bir kosa no'xat ishlatadi. 5 kosa no'xat 1 kg bo'lsa, 2 oyda necha kg no'xat ishlatiladi? 1 kg no'xatning narxi 12 000 so'm bo'lsa, 65 000 so'mlik no'xat necha kunga yetadi?

### BAJARILGAN ISHGA DOIR MASALALAR



Nargiza 1 minutda 5 ta likopcha yuvsa, 7 minutda nechta likopcha yuvadi?

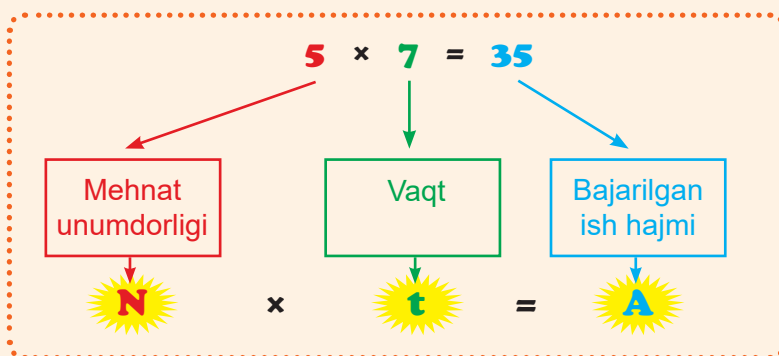

Bajarilgan ish hajmini topish uchun mehnat unumdorligi (bajarilgan ish) bu ishni bajarishga ketgan vaqtga ko'paytiriladi.

$$N = A \div t$$

Mehnat unumdorligini topish uchun bajarilgan ish hajmi vaqtga bo'linadi.

$$t = A \div N$$

Ishni bajarishga ketgan vaqtни topish uchun bajarilgan ish hajmi mehnat unumdorligiga bo'linadi.



### Guruhlarda ishlaymiz: 1–2.

1. Printer 1 minutda 7 betni chop etadi. Printer 2, 3, 5, 8, 10 betni qanchada chop etadi?

Bajarilgan ish hajmi (A), bet	2	3	5	8	10
Vaqt (t), minutda					

2. Ishchi 8 soatda 168 dona detalga ishlov berdi. Ishchining mehnat unumdorligini toping.

Berilgan:

$$t = 8 \text{ soat}$$

$$A = 168 \text{ dona}$$

$$N = ?$$

Javob: 1 soatda 21 dona.

$$N = A \div t = 168 \div 8$$

$$N = 21 \text{ (dona)}$$



### Mustahkamlash: 3-5

3. 900 betlik matnni Mubina 20 kunda, Maryam esa 30 kunda kompyuterda teradi. Opa-singillar birgalikda ishlasa, bu matnni necha kunda teradi?
4. O'quvchi 30 minutda matematikadan 2 ta, 3 ta, 5 ta, 6 ta, 10 ta test yechdi. O'quvchining mehnat unumdorligini toping. Jadvalni to'ldiring.

Jami yechilgan testlar soni (A), dona	2	3	5	6	10
Mehnat unumdorligi (N), dona					

5. Talaba 48 betlik loyiha ishini yozishi kerak. U kuniga 2, 3, 4, 6, 8, 12 betdan yozsa, loyiha ishini necha kunda yakunlaydi? Jadvalni to'ldiring.

Mehnat unumdorligi (N), dona	2	3	4	6	8	12
Vaqt (t), kun						



### Mustaqil ish: 6-8.



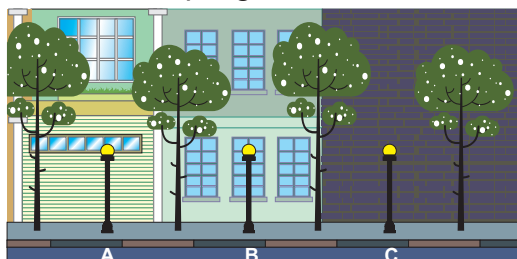



6. Ishchi a) 2; b) 4; c) 8 soatda 64 dona detalga ishlov berdi. Ishchining mehnat unumdorligini toping.
7. Traktorchi 4 soatda 12 ha yerni haydadi. U shunday mehnat unumdorligi bilan ishlasa, 6 soatda qancha yerni haydaydi?
8. Ko'chadagi daraxtlar rasmda ko'rsatilgandek bir xil masofa oralig'ida ekilgan. Ikki daraxt orasidagi masofa 8,5 m ni tashkil etadi va har bir daraxtning o'rtasida A, B va C bilan ko'rsatilgan ko'cha chiroqlari mavjud. Shunga mos ravishda A va C lampalar orasidagi masofani aniqlang.



# IX bob

## MA'LUMOTLAR BILAN ISHLASH

6 ta had

$$\frac{44 + 42 + 37 + 35 + 29 + 29}{6} = \frac{216}{6} = 36$$

$$\frac{8}{12} = \frac{24}{2n}$$

## JADVALLAR. JADVALLARNI O‘QISH VA TUZISH



### Eslaymiz!

Atmosferaga chiqarilgan ifloslantiruvchi moddalar miqdori (ming tonna).

Jadvalni o‘qiymiz.

Jadvalning ustun va qatorlarini aniqlaymiz.

Qaysi viloyat atmosferaga eng ko‘p chiqindi moddalar chiqargan?

Eng kamini-chi?

2020-yil va 2021-yillardagi ma’lumotlarni solishtiramiz.

Hududlar	2020	2021
Jami	924,4	909
Qoraqalpog‘iston Respublikasi	28,9	31
Andijon	11,5	5
Buxoro	37,1	45
Jizzax	3,4	3
Qashqadaryo	128,1	132
Navoiy	48,4	69
Namangan	15,0	24
Samarqand	52,7	39
Surxondaryo	6,5	7
Sirdaryo	71,8	46
Toshkent	430,0	425
Farg‘ona	50,5	47
Xorazm	6,8	7
Toshkent shahri	33,7	29



**Jadval** – ma’lumotlarni berishning eng qulay va keng tarqalgan turi.

**Jadval** qatorlardan va ustunlardan tashkil topadi, ularning kesishmasidagi katakka tegishli ma’lumot yoziladi.

**Sanoq jadvali** – sanoq belgilari yordamida ma’lumotlarni yig‘ish usullaridan biri.

**Sanoq belgilari** tayoqchaga (**sanoq cho‘pga**) o‘xshash to‘g‘ri chiziqlardir.



Sanoq belgilaridan foydalanish ma’lumotni ko‘rsatishning oson va qiziqarli usuli hisoblanadi.



### Guruhlarda ishlaymiz: 1.

1. Sinfdoshlaringiz yoqtirgan shirinlik turlarini ko‘rsatish uchun jadval tuzing. Raqamlar o‘rniga sanoq belgilaridan foydalaning. Jadvalni berilgan savollar orqali o‘qing.

- ❖ “Shokolad” yonida 4 ta sanoq belgisi bor, demak 4 ta do‘stingiz bu turdagi shirinlikni yoqtiradi.
- ❖ “Konfet” yonida 2 ta belgi bor, demak, 2 nafar do‘stingizga bu turdagi shirinlik yoqadi.

- ❖ “Marmelad” yonida 3 ta sanoq belgisi bor, demak, 3 nafar do‘stingizga bu turdagi shirinlik yoqadi.
- ❖ “Birortasi ham” yonida 1 ta sanoq belgisi bor, demak, 1 nafar do‘stingiz ro‘yxatdagi shirinliklarning hech birini yoqtirmaydi.
- ❖ “Muzqaymoq” (eng sevimli shirinlik) yonidagi hisob belgilariga nazar tashlasangiz, ularning biroz boshqacha ko‘rinishini payqaysiz. Sanoq belgilari 5 tadan ko‘p. Beshinchi sanoq belgisidan keyin siz yangi 5 talik guruhni boshlashingiz kerak.

Shirinliklar	Sanog‘i	Soni
Muzqaymoq		6
Shokolad		4
Konfet		2
Marmelad		3
Birortasi ham		1



### Mustahkamlash: 2–4.

2. Berilgan sabzavotlar uchun jadval tuzing va savollarga javob bering.

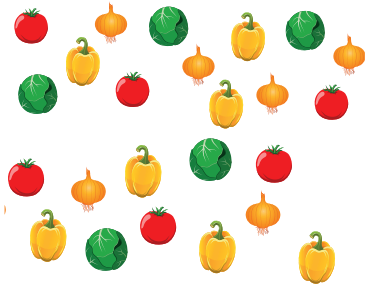

Sabzavot	Sanog‘i	Soni
Karam		
Pomidor		
Bulg‘or qalampiri		
Piyoz		

Qaysi sabzavot eng ko‘pi? Eng kami-chi?  
Jami qancha sabzavot bor?

3. Olimjon sinfdoshlari o‘rtasida yoqtirgan fanlari haqida so‘rovnoma o‘tkazdi. Natijada quyidagi jadval hosil bo‘ldi (bir necha fan tanlanishi mumkin).

Nechta o‘quvchi ingliz tili fanini tanladi?

Nechta o‘quvchi matematika yoki tabiiy fanlarni tanladi?

Qaysi fan eng ko‘p tanlandi?

Sinfda shunday so‘rovnoma o‘tkazing.

Fan	Sanog‘i
Matematika	
Ingliz tili	
Ona tili	
Tabiiy fanlar	
Tarix	

4. Jadvalda mahalladagi go‘zallik saloniga mijozlar tashrifi haqida ma‘lumot keltirilgan.

- 1) Seshanba kuni qancha mijoz keldi?
- 2) Qaysi kuni ko‘proq mijoz keldi?
- 3) 24 dan ortiq mijoz necha kunda keldi?
- 4) Qaysi kuni eng kam mijoz keldi?
- 5) 32 ta mijoz necha kunda keldi?
- 6) Dushanba kuni qaysi kunlardagidan kamroq mijoz kelgan?

Kun	Mijozlar
Dushanba	
Seshanba	
Chorshanba	
Payshanba	
Juma	
Shanba	
Yakshanba	



### Mustaqil ish: 5.

5. Sinflararo futbol musobaqasi jadvalini o'rganing va savollarga javob bering.

Sinf	1	2	3	4	5	G'alaba	Durang	Mag'lubiyat	Ochko	O'rin
6-A		2:3	1:2	0:0	2:1	1	1	2	4	4
6-B	3:2		5:0	0:1	4:2	3	-	1	9	1
6-C	2:1	0:5		1:1	2:0	2	1	1	7	2
6-D	0:0	1:0	1:1		2:2	1	3	-	6	3
6-E	1:2	2:4	0:2	2:2		-	1	3	1	5

- 1) Qaysi jamoa eng ko'p g'alaba qozongan?
- 2) Qaysi jamoa eng kam g'alaba qozongan?
- 3) Qaysi jamoa eng ko'p durang natija qayd etgan?
- 4) Qaysi jamoa eng kam durang natija qayd etgan?
- 5) Qaysi jamoa eng ko'p gol urgan? Eng kami-chi?
- 6) Qaysi jamoa bitta o'yinda eng ko'p gol urgan?
- 7) Qaysi natija eng ko'p uchragan?
- 8) Eng kam gol kiritgan jamoa musobaqada g'olib bo'lishi mumkinmi?
- 9) Eng kam g'alaba qozongan jamoa musobaqada g'olib bo'lishi mumkinmi?

### MA'LUMOTLAR QATORI



#### Ma'lumotlar berilishining eng sodda shakllari

1)  $+12\text{ }^{\circ}\text{C}$ ,  $+14\text{ }^{\circ}\text{C}$ ,  $+15\text{ }^{\circ}\text{C}$ ,  $+10\text{ }^{\circ}\text{C}$  – ma'lumotlar qator shaklida berilishi

2) ma'lumot grafik shaklida berilishi

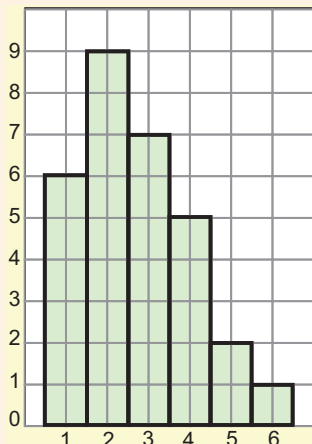

3) ma'lumotlar jadval shaklida berilishi

Kunlar	Harorat
Seshanba	$+15\text{ }^{\circ}\text{C}$
Chorshanba	$+17\text{ }^{\circ}\text{C}$
Payshanba	$+13\text{ }^{\circ}\text{C}$
Juma	$+14\text{ }^{\circ}\text{C}$
Shanba	$+18\text{ }^{\circ}\text{C}$
Yakshanba	$+19\text{ }^{\circ}\text{C}$





## Guruhlarda ishlaymiz: 1–2.

1. Berilgan ma'lumotlarni jadval va grafik shaklida tasvirlang.

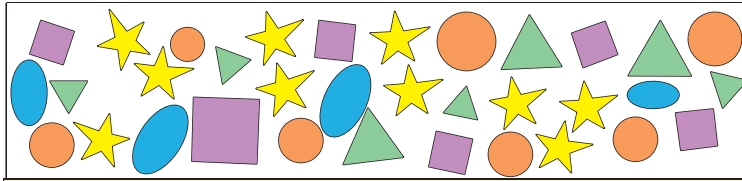

- 1) Jami nechta shakl bor?
  - 2) Qaysi shakl ko'proq uchraydi?
  - 3) Qaysi shakllar ko'proq: uchburchaklarmi yoki kvadratlarmi?
2. O'qituvchi o'z sinfiga matematikadan 10 ta savolli test berdi. Quyidagi natijalar qayd etildi: 9, 7, 8, 6, 4, 7, 10, 9, 8, 7, 6, 7, 5, 5, 10, 9, 8, 8, 7, 9, 10, 5, 7, 6, 8, 8, 7, 9, 6, 9.
- 1) Eng yuqori natija necha ball?
  - 2) Eng past natija necha ball?
  - 3) Ma'lumotlar uchun jadval, gistogramma tuzing.
  - 4) Eng ko'p tarqalgan natija necha ball?
  - 5) Nechta o'quvchi 7 tadan kam savolga to'g'ri javob berdi?
  - 6) Nechta o'quvchi atigi 2 yoki undan kam xatoga yo'l qo'ygan?



## Mustahkamlash (amaliy ish).

### 1-amaliy ish

O'yin kubigini 33 marta tashlanganda quyidagi natijalar qayd etildi:

4, 2, 3, 1, 3, 4, 6, 1, 5, 3, 4, 6, 6, 3, 4, 2, 1, 1, 4, 5, 6, 3, 4, 5, 1, 3, 5, 4, 2, 6, 1, 2, 5.

- 1) Ma'lumotlarni jadvalga yozing.
- 2) Qaysi natija eng katta songa ega?
- 3) Qaysi natija eng kichik songa ega?
- 4) Agar siz bu kubikni yana 33 marta tashlasangiz, xuddi shunday natijaga erishasizmi? Tekshirib ko'ring.

### 2-amaliy ish

Ertalab maktab darvozasi yonidan o'tadigan avtotransport vositalari to'g'risida ma'lumotlarni to'plang hamda uni jadval yoki diagramma shaklida yozing.

### 3-amaliy ish

Ikkita o'yin kubigi bir necha marta tashlanganida natijalar juda qiziq chiqdi. Ko'pincha qanday yig'indi bo'lishini kutsa bo'ladi? Buni bilish uchun natijalarni jadval shaklida yozing.

### 4-amaliy ish

Har bir sinfdoshingizning oilasidagi bolalar soni bo'yicha to'plangan ma'lumotlarni jadvalga yozing. Shuningdek, ushbu ma'lumotni ko'rsatadigan diagrammani tuzing.

### 5-amaliy ish

Sinfdozlaringiz orasida musiqaning qaysi turi ko'proq eshutilishini bilish uchun so'rovnoma o'tkazing. Quyidagi jadvalni tuzib, mos diagramma yasang.

Tur	Sanog'i	Soni
Klassik		
G'arb		
Hind		
Milliy estrada		
Turk estradasi		
Rus estradasi		
Boshqa		

### 6-amaliy ish

Sinfdozlaringiz sportning qaysi turiga ko'proq qiziqishini bilish uchun so'rovnoma o'tkazing. Quyidagi jadvalni tuzib, mos diagramma yasang.

Tur	Sanog'i	Soni
Futbol		
Voleybol		
Basketbol		
Yugurish		
Suzish		
Shaxmat		
Boshqa		



### Mustaqil ish

#### 1-amaliy ish

Kundaligingizdan foydalanib oxirgi oyda qancha va qanday baholar olganingizni o'rganib chiqing. Natijalarni gistogramma ko'rinishida ifodalang.

#### 2-amaliy ish

"Adabiyot" darsligidan yoqtirgan she'ringizni tanlab oling va undagi unli harflar sonini sanab chiqing. Mos jadval va gistogramma tuzing. Qaysi harf ko'proq uchraydi? Natijangizni boshqa sinfdoshlaringizniki bilan solishtiring.

Unli harflar	A	E	I	O	U	O'
Soni						

## MA'LUMOTLAR TAHLILI

 Eslaymiz!

Futbol musobaqasida har bir jamoa nechtadan o'yin o'tkazgan?

Jamoalarning ochkosi to'g'ri hisoblanganmi?

Ochkolar qanday hisoblangan?

No	Jamoalar	O'yin	Yutuq	Durang	Mag'lubiyat	Ochko
1	Paxtakor	17	14	2	1	44
2	OKMK	19	12	6	1	42
3	Nasaf	19	10	7	2	37
4	Metallurg	18	10	5	3	35
5	Qo'qon-1912	18	9	2	7	29
6	Bunyodkor	17	8	5	4	29

Jadvaldagi ma'lumotlarning statistik tahlili qanday amalga oshiriladi?



## O'zgarish kengligi

Jadvaldagi **eng katta** ochko nechaga teng? → 44

Jadvaldagi **eng kichik** ochko nechaga teng? → 29

Berilgan ma'lumotlar qatoridagi eng katta had bilan eng kichik had ayirmasi **o'zgarish kengligi** deyiladi.

$$\text{O'zgarish kengligi} \rightarrow 44 - 29 = 15.$$

- O'zgarish kengligi ma'lumotlar qanday tarqalishi haqida taxminiy tasavvur beradi.
- O'zgarish kengligi ma'lumotlar qatorining eng katta va eng kichik hadlari orasidagi farq sifatida aniqlanadi.



## Guruhlarda ishlaymiz: 1–5.

- Jadvalda bir hafta davomida har kuni muzeyga keladigan odamlar soni ko'rsatilgan. Ma'lumotlar qatoridan o'zgarish kengligini toping.
  - Eng ko'p tashrif qaysi kuni bo'lgan?
  - Eng kam tashrif qaysi kuni bo'lgan?
  - Shu kuni necha nafar odam muzeyga tashrif buyurgan? Eng kam kuni-chi?
  - O'zgarish kengligi nechaga teng?

Kunlar	Odamlar soni
Seshanba	15
Chorshanba	35
Payshanba	83
Juma	90
Shanba	42
Yakshanba	51



## O'rta arifmetik qiymat

$$\frac{44 + 42 + 37 + 35 + 29 + 29}{6} = \frac{216}{6} = 36$$

Ma'lumotlar qatorida o'rta arifmetik qiymatni topish uchun barcha hadlarning yig'indisini hadlar soniga bo'lish kifoya.

2. Shaxmat musobaqasida 6-sinfning 8 nafar o'quvchisi 13; 13; 12; 13; 10; 13; 12; 10 ochko to'pladi. Ular olgan ochkolarning o'rta arifmetik qiymatini toping.



### Mediana

Ma'lumotlar qatoridagi hadlar o'sib borish tartibida yoziladi.

Ma'lumotlar qatoridagi hadlar soni toq bo'lsa, mediana eng o'rtada turgan son bo'ladi.

$$13, 14, 12, 15, 18 \rightarrow 12, 13, 14, 15, 18$$

Ma'lumotlar qatoridagi hadlar soni juft bo'lsa, mediana o'rtada turgan ikkita son o'rta arifmetigi bo'ladi.

$$44, 42, 37, 35, 29, 29 \rightarrow 29, 29, 35, 37, 42, 44$$

$$\frac{35+37}{2} = \frac{72}{2} = 36 \rightarrow \text{mediana}$$

3. Jadvalda bir haftalik ob-havo ma'lumoti berilgan. Uning medianasini toping.

Kunlar	Harorat
Seshanba	+15 °C
Chorshanba	+17 °C
Payshanba	+13 °C
Juma	+14 °C
Shanba	+18 °C
Yakshanba	+19 °C



### Moda

Ma'lumotlar qatoridagi eng ko'p takrorlanadigan had modadir.

$$44, 42, 37, 35, \underbrace{29, 29}_{2 \text{ ta}} \rightarrow \text{bu yerda moda } 29$$

$$17, 28, 29, 41, 37, 18 \rightarrow \text{bu yerda moda } \text{yo'q}$$

$$28, 34, \underbrace{41, 44, 28, 41}_{2 \text{ ta}}, 18, 39 \rightarrow \text{bu yerda moda } 28 \text{ va } 41$$

4. Jadvalda barcha 6-sinf o'quvchilarining choraklik baholari to'g'risida ma'lumotlar berilgan. Uning modasini toping.

Baholar	Soni
"5"	48
"4"	34
"3"	48
"2"	8

5. Ushbu qator uchun o'zgarish kengligi, o'rta arifmetik mediana va modani aniqlang: 6, 9, 7, 3, 9, 4, 7, 6, 5.



### Mustahkamlash: 6–16.

6. Ushbu qatorlarning o'zgarish kengligi, o'rta arifmetik qiymati, mediana va modasini aniqlang.
- a) 2, 5, 3, 4, 5  
 b) 7, 9, 6, 9, 8, 7, 7  
 c) 10, 20, 10, 50, 40, 30  
 d) 17, 20, 19, 22, 21, 17, 20  
 e) 49, 50, 48, 51, 50  
 f) 8, 10, 12, 7, 8, 10, 9, 8, 10, 8, 11  
 g) 5, 4, 6, 3, 2, 4, 6, 9, 4, 7, 3, 2  
 h) 147, 151, 148, 150, 148, 152, 151

7. Bolalarning bo'yi uzunligining o'zgarish kengligi, o'rta arifmetik qiymati, mediana va modasini aniqlang.

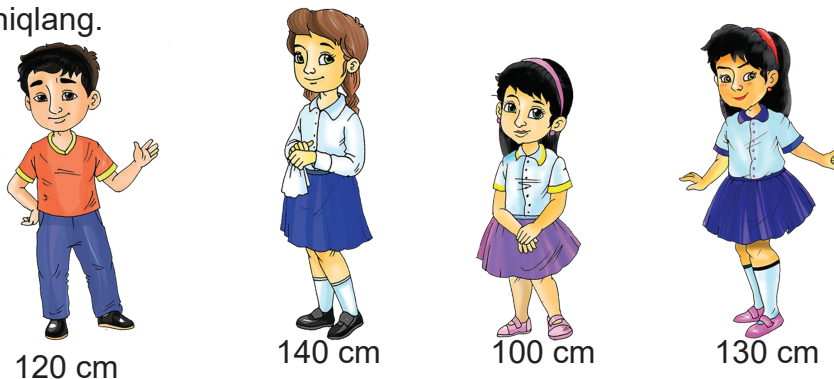

8. Sinf o'quvchilarining choraklik o'zlashtirish baholarining modasi, o'zgarish kengligini aniqlang.  
 Barcha darslarni "5"ga o'zlashtirganlar soni – 8  
 "4" ga o'zlashtirganlar soni – 14  
 "3" ga o'zlashtirganlar soni – 10
9. Sotuvchi bir kunda 37 ta ertak kitobi, 120 ta darslik, 16 ta texnikaga oid kitob, 24 ta rasm daftari, 9 ta geografik atlas sodi. Xaridorlar uchun qaysi mahsulot moda bo'ldi?
10. Davron ovlagan baliqlarining massasini alohida-alohida o'lchaganida ularning massalari: 1,2 kg; 3,24 kg; 1,9 kg; 2,16 kg; 2 kg ekani aniq bo'ldi. Davron ovlagan bitta baliqning o'rtacha massasi necha kilogramm? Baliq massalarining o'zgarish kengligi necha kilogramm?
11. Yanvar oyining bir sutkasida havoning harorati ertalab  $+2\text{ }^{\circ}\text{C}$ , tushda  $+6\text{ }^{\circ}\text{C}$ , tushdan keyin  $+4\text{ }^{\circ}\text{C}$ , kechqurun  $+3\text{ }^{\circ}\text{C}$ , tunda  $0\text{ }^{\circ}\text{C}$  bo'ldi.
- 1) Havoning sutkalik o'rtacha harorati necha gradus?
  - 2) Sutka davomida havoning o'zgarish kengligi qanday?
  - 3) O'sha sutkadagi havo haroratining medianasi necha gradus?
  - 4) O'sha sutkadagi havo haroratining modasi bormi?
12. Kombaynchi g'alla o'rimi paytida: 1-kuni 15,2 ha, 2-kuni 18,6 ha, 3-kuni 16,2 ha, 4-kuni 14,7 ha, 5-kuni 17,3 ha yer maydonida g'alla o'rdi. Kombaynchi bir kunlik g'alla o'rgan yer maydonining o'rtacha qiymatini toping. Uning o'zgarish kengligini hisoblang. Modasi bormi?

**13.** 3-chorakda olgan barcha baholaringizning o'рта arifmetigini, o'zgarish kengligi va medianasini toping.

**14.** Fermer 6 ha yerga bug'doy ekib, uning 1-gektaridan 34 q, 2-gektaridan 36 q, 3-gektaridan 35 q, 4-gektaridan 37 q, 5-gektaridan 34 q, 6-gektaridan 37 q hosil oldi.

Fermer olgan bug'doyning o'rtacha hosili necha sentner? Modasi necha sentner? Medianasini toping.

**15.** Jismoniy tarbiya darsida o'quvchilar guruhining 100 m masofaga yugurgan vaqti ko'rsatkichlari jadvali berilgan.

Jadvalga asosan:

a) vaqtlarining o'рта arifmetigini;

b) vaqtning o'zgarish kengligini;

c) o'quvchilar yugurgan vaqtlarning medianasini toping.

O'quvchilarning ismlari	Yugurib o'tgan vaqti (sekund hisobida)
Aziz	14,1
Alisher	18,2
Dilshoda	15,5
Zuhro	16,2
Marjona	22,4
Rustam	16,2

**16.** Farhod usta shogirdlari bilan birgalikda birinchi kuni 1 000 ta, ikkinchi kuni 1 200 ta, uchinchi kuni 1 900 ta, to'rtinchi kuni 2 200 ta g'isht terdi. Har bir terilgan g'isht uchun 250 so'm pul beriladi. Jamoa jami necha so'm pul olgan? Terilgan g'ishtlar sonining o'рта arifmetik qiymati hisoblansa, pul miqdori qanday o'zgaradi?



### Mustaqil ish: 17–18.

**17.** O'yinchoq mashina bosib o'tadigan masofani rasmdagi kabi turli xil balandliklarda sinang. Barcha masofalarni o'lchab, o'rtacha bosib o'tilgan yo'lni toping. O'zgarish kengligi va modasini topa olasizmi?



**18.** Dekabr oyining bir sutkasida havo harorati ertalab, tushda, kechqurun va tunda o'lchandi. O'lchash natijalari bo'yicha o'sha kundagi havoning sutkalik o'рта arifmetik qiymati  $-6^{\circ}\text{C}$  bo'ldi. Tushdagi havo harorati ertalabki haroratga nisbatan  $3^{\circ}\text{C}$  sovuq, kechqurungi harorat  $1^{\circ}\text{C}$  va tungi harorat  $4^{\circ}\text{C}$  sovuq bo'ldi. Havo haroratining sutka davomidagi o'zgarish kengligini, medianasini toping.

## TAKRORLASH

1. Alisher bir oyda 6 ta sayt va telegram bot tayyorlab berish uchun buyurtma oldi. Bu ish uchun 8,3 mln so'm oladigan bo'ldi. Buyurtmachi unga kelishilgan pulning  $\frac{3}{8}$  qismini hozir va qolgan pulni ish yakunlangach, beradi. Ishni tugatgach, Alisher yana qancha pul oladi?
2. Oshxona devoriga yopishtirish uchun ketadigan jami kafelning  $\frac{5}{9}$  qismi keltirildi. Bir kunda bu kafellarning  $\frac{4}{9}$  qismi terildi. Oshxonaga ketadigan jami kafelning qancha qismi terilgan? Yana qancha qism ish qoldi?
3. Sohiba qo'g'irchoq tikish uchun  $1\frac{3}{5}$  m mato sotib oldi. Bitta qo'g'irchoq uchun  $\frac{4}{25}$  m mato ketar ekan. Sohiba olgan matosidan nechta qo'g'irchoq tika oladi?
4. Dilzoda kiyim tikish uchun  $4\frac{2}{3}$  m material sotib oldi. Uning  $\frac{6}{7}$  qismini ishlatdi. U necha metr material ishlatdi? Chizmada qanday yechim tasvirlangan?

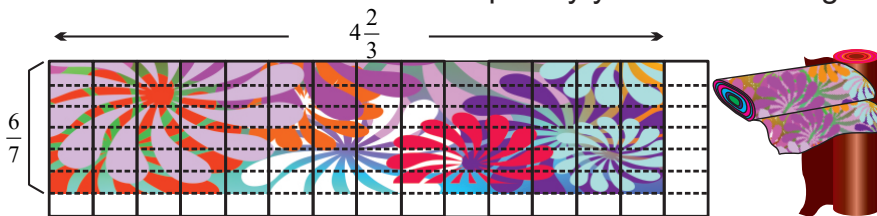

5. Jadvalni to'ldiring.

Misol	Bo'luvchiga teskari son	Bo'lishni ko'paytirishga almashtirish qadami	Bo'linma
$8 \div \frac{5}{6}$	?	$8 \times \frac{6}{5}$	?
$14 \div \frac{2}{3}$	?	$14 \times \frac{3}{2}$	?
$27 \div \frac{9}{13}$	$\frac{13}{9}$	?	?
$20 \div \frac{4}{70}$	$\frac{70}{4}$	?	?

6. Ko'paytirish va bo'lishni bajaring.

a)  $8\frac{3}{8} \times 2\frac{5}{6}$

b)  $16\frac{4}{5} \times 12\frac{1}{7}$

c)  $25\frac{5}{8} \times 11\frac{2}{3}$

d)  $4\frac{5}{32} \times 2\frac{4}{133}$

e)  $\frac{3}{4} \div 1\frac{7}{8}$

f)  $11\frac{3}{9} \div 12\frac{3}{4}$

g)  $14\frac{1}{3} \div 6\frac{1}{7}$

h)  $15\frac{2}{3} \div 7\frac{5}{6}$

7. Dilshod  $\frac{3}{4}$  kilogramm pishloq sotib oldi. Agar uni har biri  $\frac{1}{8}$  kg bo'lgan qismlarga ajratsa, nechta qism hosil bo'ladi?
8. Alisherda  $1\frac{1}{2}$  litr sharbat bor edi. U sharbatni stakanlarga quyishi kerak. Har bir stakanga  $\frac{1}{4}$  litr sharbat sig'adi. Barcha sharbatni quyish uchun unga nechta stakan kerak bo'ladi?
9. Ifodaning qiymatini toping.
- a)  $\frac{0,21 \times 0,21 \times 0,21 + 0,021 \times 0,21 \times 0,021}{0,63 \times 0,63 \times 0,63 + 0,063 \times 0,63 \times 0,063}$
- b)  $\frac{0,1 \times 0,1 \times 0,1 + 0,02 \times 0,02 \times 0,02}{0,2 \times 0,2 \times 0,2 + 0,04 \times 0,04 \times 0,04}$
- c)  $617 + 6,017 + 0,617 + 6,0017$
- d)  $6202,5 + 620,25 + 62,025 + 6,2025 + 62025$

10. Har bir stakaning 9,1 cm i ostidagi stakanga tushadi, har bir stakan – 10 cm. Stakanlarning 100 tasini bir to'plam qilib o'ralsa, ushbu to'plam balandligi necha cm bo'ladi?

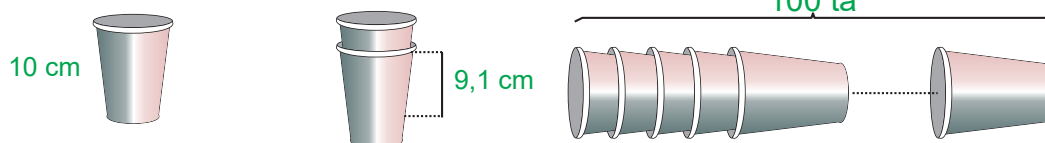

11. Tolib poygani yakunlash uchun 3,25 minut, Ravshan esa 3,207 minut yugurdi. Poygada kim g'olib chiqdi? U necha sekund farq bilan yutdi?
12. Avtomobil 2,3 litr benzin bilan 48,3 km yo'l bosib o'tadi. U 1 litr benzin bilan qancha masofani bosib o'tadi? 1 litr benzin narxi 5 278 so'm bo'lsa, avtomobil jami masofaga necha so'mlik benzin ishlatgan?
13. Sut sog'uvchi korxonaga ertalab 50,25 litr, kechqurun esa 20,75 litr sut beradi. Sog'uvchi bergan sutning umumiy miqdori qancha? U sutning litrini qayta ishlash firmasiga 1 850 so'mdan topshirsa, unga qancha pul beriladi?
14. Sportchi haftada 4 kun, 1,5 soatdan jang san'ati bilan shug'ullanadi. Bir hafta 7 kun ekanini hisobga olsak, uning har haftada kuniga o'rtacha mashg'ulot vaqti qancha?
15. Maqsud 8,6 kg shakar sotib oldi. U shakarni 5 ta stakanga teng ravishda bo'ldi. 0,35 kg shakar ortib qoldi. 1 ta stakandagi shakarning massasi qancha?
16. Xristofor Kolumb 41 yoshida birinchi marta Atlantika okeanini suzib o'tdi. U oxirgi ekspeditsiyasini oradan 10 yil o'tib boshladi va bu 2 yil davom etdi. U oxirgi ekspeditsiyasi tugatganidan 2 yil o'tgach, 1506-yilda vafot etdi. Kolumb nechanchi yilda tug'ilgan?



17. Sariq uchburchaklar sonining barcha uchburchaklar soniga nisbati qanday?

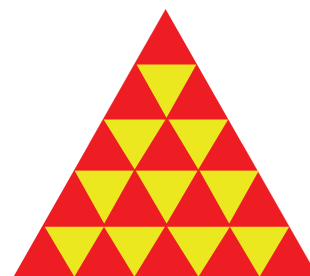

18. Noma'lumlarni toping.

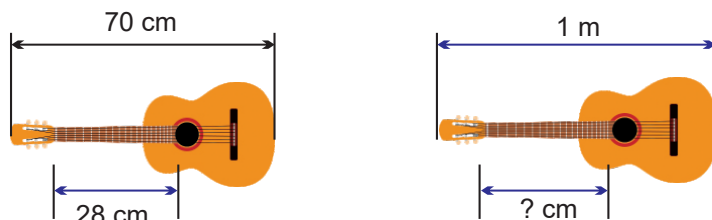

19. Berilgan ma'lumotlar asosida noma'lumlarni toping.

- 18 soni qaysi sonning 75% ini tashkil qiladi?
- 200 ning 15% ini toping.
- 75 soni 125 ning necha foizini tashkil qiladi?
- 33 soni 44 ning necha necha foizini tashkil qiladi?
- 8,5% i 2 642 bo'lgan sonni toping.
- 62 soni 248 ning necha foizini tashkil etadi?
- 120 ning 40% i nechaga teng?
- 18 soni 350 ning necha foizini tashkil qiladi?
- 35% i 16,8 bo'lgan son nechaga teng?
- 14% i 720 bo'lgan sonni toping.

20. Tenglamani yeching.

a)  $\frac{x}{8} = \frac{2}{4}$

b)  $\frac{9}{7} = \frac{y}{21}$

c)  $\frac{22}{12} = \frac{14}{x}$

d)  $\frac{12}{x} = \frac{4}{9}$

e)  $\frac{5b}{12} = \frac{26}{16}$

f)  $\frac{24}{7y} = \frac{62}{15}$

g)  $\frac{46}{34} = \frac{9k}{51}$

h)  $\frac{x+9}{6} = \frac{5}{2}$

21. Lift dastlab 8-qavatda edi. U 5 qavatga, keyin yana 15 qavatga ko'tarildi, so'ng 8 qavat pastga tushib, 2 qavat yuqoriga ko'tarildi. Undan so'ng 5 qavat pastga tushdi. Lift hozir nechanchi qavatda?

22. Namuna asosida toping.

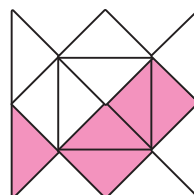
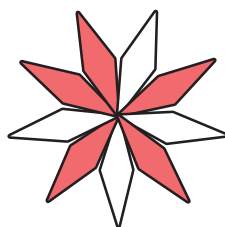
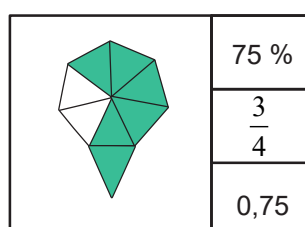

23. Berilgan ma'lumotlardan foydalanib masalani yeching. Ushbu masala proporsional bog'lanishning qaysi turiga kiradi?

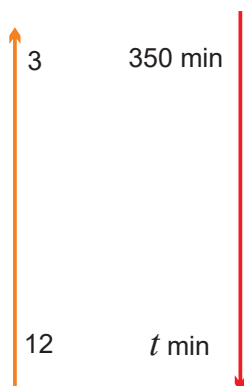
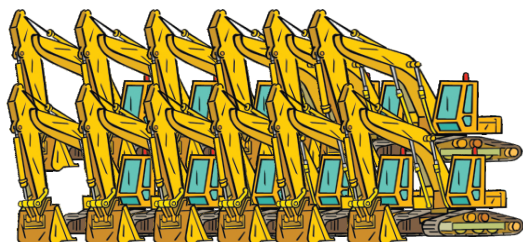

24. Xaritada 2,7 cm uzunlikdagi kesmaga haqiqiy o'lchamda 54 km masofa mos keladi. Agar xaritada ikki shahar orasidagi masofa 12,6 cm bo'lsa, ular orasidagi masofa haqiqiy o'lchamda necha kilometr bo'ladi?

25. Son o'qidan foydalanib quyidagi misollarni yeching.

- |                |                  |                |                |
|----------------|------------------|----------------|----------------|
| a) $6 + (-3)$  | b) $+4 - (+2)$   | c) $8 + (+1)$  | d) $-2 + (+4)$ |
| e) $-3 - (-4)$ | f) $-10 + (+10)$ | g) $6 - (+6)$  | h) $-3 + (-2)$ |
| i) $-1 + (+2)$ | j) $-7 - (+4)$   | k) $+4 - (-2)$ | l) $+5 - (-1)$ |

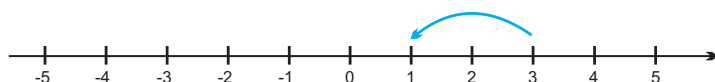

Namuna:  $+3 - (+2)$ ;  $+3 + (+2)$

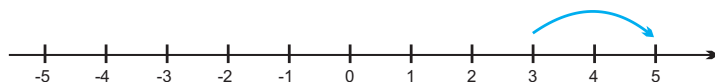

26. Quyidagi sonlarning butun qiymatini aniqlang.

- |   |   |  |
|---|---|--|
| a) $-\left(\frac{-8}{2}\right)$               | b) $-\left(+\left(-\left(\frac{-9}{-2}\right)\right)\right)$  | c) $-\left(\frac{-10}{-5}\right)$  |
| d) $-\left(-\left(\frac{-4}{2}\right)\right)$ | e) $+\left(-\left(-\left(\frac{+12}{-6}\right)\right)\right)$ | f) $+\left(-\left(-\left(+\left(-\left(-\frac{-20}{+4}\right)\right)\right)\right)\right)$ |

27. Amallarni bajaring.

- |  |  |
|--|--|
| a) $-14 \times (-2) + (-8)$              | b) $+63 - (-4 \times (-3))$              |
| c) $45 \times (-4) - 28 \times (-4)$     | d) $-12 \times (-4) - (-14 \times (-6))$ |
| e) $-42 \times (+3) + (-21 \times (-3))$ | f) $13 \times (-6) - 32 \times (-3)$     |

28. Amallarni bajaring.

- a)  $-45 \times (-9) \div (-15) - 6 \times (-63 \div (-7) - 45)$

b)  $-72 \div 9 + (-18 - 156 \div (-12))$

c)  $35 \times (-21) \div (-7) - (-(+4))$

e)  $-32 \times 2 + (-42 \div (-21) - 15 \times (-4))$

d)  $-98 \times (-17 \times 4 - 12 \div (-6))$

f)  $25 \div (+5) - 34 \times (-2) + 45$

- 29.** Bahodir soat 18:00 da termometrni ko'rganda  $+1$  °C ni ko'rsatgan edi. Harorat har soatda ikki gradus pastlab borgan bo'lsa, termometr tungi 12 da necha gradusni ko'rsatadi?
- 30.** Xona haroratidagi metall simob suyuqlikdir. Uning erish nuqtasi  $-39$  °C. Laboratoriya spirtning muzlash nuqtasi  $-114$  °C. Simobning erish nuqtasi spirtning muzlash nuqtasidan necha gradus issiqroq?
- 31.** Puni urushlari miloddan avvalgi 264-yilda boshlanib, miloddan avvalgi 146-yilda tugagan. Puni urushlari qancha vaqt davom etgan?
- 32.** Shahloxon quyidagi ro'yxatdagi uchta turli sonni ko'paytirmoqchi:  $-5$ ,  $-3$ ,  $-1$ ,  $2$ ,  $4$  va  $6$ . U qanday eng kichik natijaga erisha oladi?
- 33.** Harorat  $-18$  °C dan  $19$  °C ga ko'tarildi. Harorat necha gradus ko'tarildi?
- 34.** Davron 6-sinfda o'qiydi. U ingliz tilini o'rganib frilanserlik qilmoqchi. Frilanserlik saytlariga kirib, bitta so'zni ingliz tilidan o'zbek tiliga tarjima qilish 2 sent ekanini, bir sahifada taxminan 450 ta so'z bo'lishini bildi. U hikoyalar to'plamini tarjima qilish uchun oldi. Kitob 86 bet ekan. U ushbu kitobni tarjima qilish orqali qancha pul ishlab topadi? Dollarning ayni kundagi rasmiy kursi bo'yicha so'mda hisoblang.
- 35.** Quyidagi ifodalarga berilgan sonlarni qo'yib, hisoblang.
- a)  $\frac{s+(-7)}{-6+s} + 2$ , bunda  $s = -3$
- b)  $452 + d - (-27) + 324$ , bunda  $d = -32$
- c)  $-5b + (-6)n - 320$ , bunda  $b = -42$ ,  $n = -3$
- d)  $\frac{7c+12}{-2c}$ , bunda  $c = -36$
- e)  $h(-7-s) + (-5)$ , bunda  $h = -4$ ,  $s = -3$
- f)  $\frac{6q-p}{4q}$ , bunda  $p = -2$ ,  $q = 12$
- 36.** Bir son 26 ga ko'paytirildi va hosil bo'lgan yangi son 3 ga bo'lindi. Natija 18 chiqqan bo'lsa, ilk sonni toping.
- 37.** Ota o'g'lidan 27 yoshga katta. Agar ularning yoshi yig'indisi 47 bo'lsa, o'g'il va otasining yoshini toping.
- 38.** Solihaning otasi 49 yoshda. U Solihaning yoshidan to'rt baravar va 5 yosh katta. Soliha necha yoshda?
- 39.** Teng yonli uchburchakning asosidagi burchaklari teng, boshqa burchagi  $80^\circ$ . Asosdagi burchaklarning o'lchamini toping.

40. Qalamning narxi o'chirg'ich narxidan 250 so'm qimmat. Agar 8 ta qalam va 10 ta o'chirg'ichning narxi 12 800 bo'lsa, har birining narxini toping.
41. 36 sonini biri uning  $\frac{1}{5}$  iga, ikkinchisi  $\frac{1}{7}$  iga teng bo'ladigan tarzda ikki qismga bo'ling.
42. Ketma-ket kelgan uchta sonning yig'indisi 54 ga teng. O'rta sonni  $a$  deb olib, uchala sonni toping.
43. Ketma-ket kelgan uchta sonning yig'indisi 81 ga teng. Ushbu sonlarni toping.
44. Ketma-ket kelgan beshta sonning yig'indisi 70 ga teng. Ushbu sonlarni toping.
45. Tenglamani yeching.
- a)  $2(x-3) - 3(x-4) = 12$       b)  $5y - 15 = 27 - 2y$       c)  $3\frac{2}{5} - y = 2\frac{1}{2}$
- d)  $3z - 18 = z - (12 - 4z)$       e)  $\frac{y}{8} - 2,1 = -2,8$       f)  $\frac{2m}{8} = -1\frac{7}{9} + 2\frac{2}{3}$
46. Uchlari  $A(-1; 6)$ ;  $B(2; 6)$ ;  $C(2; 2)$  nuqtalarda bo'lgan uchburchak chizamiz va uning turini aniqlaymiz.
47. Teng yonli uchburchakning perimetri 100 cm. Agar asos 36 cm bo'lsa, tomonlarning uzunligini toping.
48. Avazbek yog'ochdan uchburchak shaklidagi qush uyini qurmoqda. Agar burchaklardan ikkitasi  $50^\circ$  va  $80^\circ$  bo'lsa, uchinchi burchakning o'lchami nechaga teng?
49. Kvadrat va teng tomonli uchburchakning perimetri bir xil deb faraz qilaylik. Agar kvadratning tomoni 15 cm bo'lsa, uchburchak tomoni va kvadratning perimetrini toping.
50. Quyida ko'rsatilgan teng yonli uchburchak shaklidagi bolalar o'yingohini ikki qator qilib o'rashga qancha yog'och to'siq kerak bo'lishini hisoblab ko'ring. Maydonning yon tomoni 60 m, katta tomoni 100 m.



51. To'g'ri burchakli, teng yonli uchburchakning noma'lum burchaklarini toping.

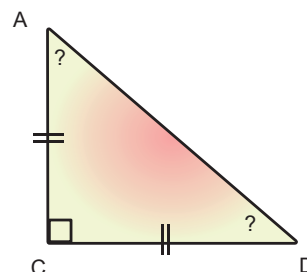

52. Noma'lum burchakni toping.

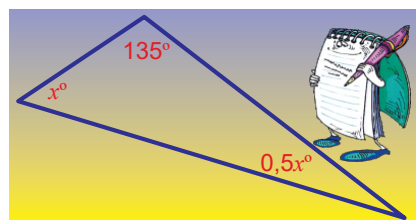

53. Berilgan shakl yuzini toping.

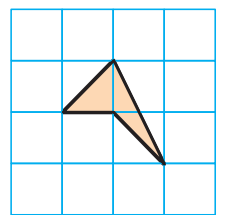
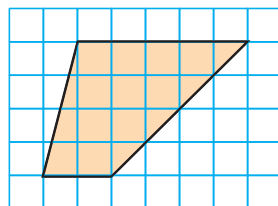
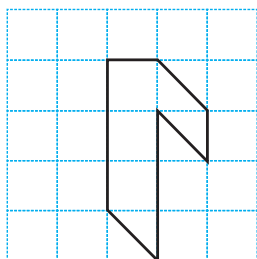

54. Aylanani uch marta kesib o'tadigan chiziq bo'lishi mumkinmi? Agar shunday bo'lsa, bittasini chizing. Agar yo'q bo'lsa, tushuntiring.

55. Agar dumaloq hovuzning radiusi 20 birlik bo'lsa, uning diametri uzunligi qancha?

56. Javlon aylana shaklidagi basseynga suzishga boradi. Suzishdan so'ng u basseyn chegarasi bo'ylab bir marta to'liq yuguradi. Hovuzning radiusi 35 metr bo'lsa, Javlonning hovuz atrofida yugurgan masofasini topa olasizmi?

57. Siz aylana shaklidagi stolingiz ustini gulqog'oz bilan bezashni xohladingiz. Agar stol usti radiusi 50 cm bo'lsa, uning yuzasini qoplash uchun kerak bo'ladigan gulqog'oz miqdorini toping.

58. Rasul va uning do'stlari pitsa buyurtma qilishdi. Har bir bo'lak uzunligi 15 cm edi. Buyurtma qilingan pitsa yuzasini hisoblang. Pitsa bo'lagi uzunligini pitsa radiusiga teng deb olishingiz mumkin.

59. Dumaloq soat ko'rsatayotgan vaqt 15:00. Minut milining uzunligi 21 birlik. Vaqt 15:30 bo'lganda, minut mili bosib o'tgan masofani toping.

60. Quyidagi shakllarning perimetrini toping.

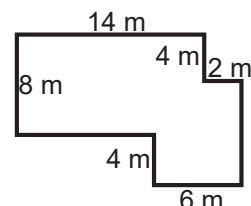
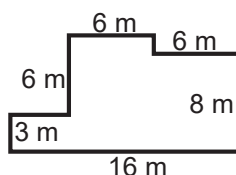
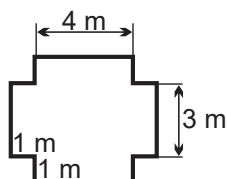
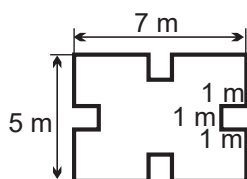
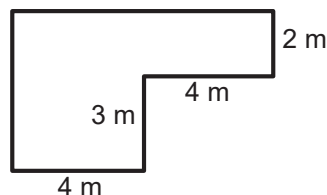
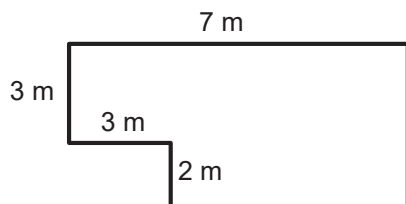

## QIZIQARLI VA MANTIQIY TOPSHIRIQLAR

1. (Al-Xorazmiy masalasi) Sondan uning uchdan biri va to'rtidan biri ayrilsa, 8 qoladi. Sonning o'zini toping.
2. Shahlo kirsovun oldi. 7 marta kir yuvganidan so'ng sovunning eni, bo'yi va balandligi 2 marta kamaydi. Sovun yana necha marta kir yuvishga yetadi?
3. Yangi bino 100 ta xonadondan iborat edi. Uylarni raqamlash uchun 0 dan 9 gacha bo'lgan raqamlar tayyorlandi. Jami nechta 9 raqami tayyorlangan?
4. Salim bobo, agar shanba va yakshanbani hisobga olinmasa, 55 yoshda. Agar hamma kunlar hisoblansa, Salim bobo necha yoshda?
5. Mebel do'konida 3 xil divan-kreslo bor. Ular bir xil qismlardan tayyorlangan. Kichik divanda 1 ta o'tirgich, 2-sida 2 ta va kattasida 3 ta o'tirg'ich bor. Agar katta divanning uzunligi suyangichlari bilan birga 220 cm, ikkinchisining uzunligi 160 cm bo'lsa, kichik divanning uzunligini toping.

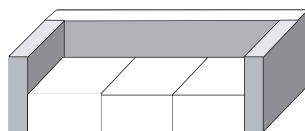

220 cm

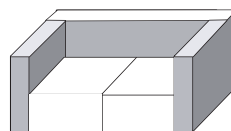

160 cm

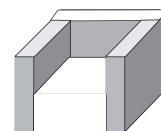

6. Sizda 100 so'm pul bor. Qo'ying 3 tasi – 1 so'm, mol – 1 so'm, ot – 5 so'm. Siz shu pulga jami 100 ta: qo'y, mol, ot olishingiz mumkinmi?
7. Kirish eshigi kodini aniqlang.



6	8	2	Bu qatordagi raqamlarning bittasi to'g'ri va turgan o'rni ham to'g'ri
6	1	4	Bu qatorda esa raqamlarning bittasi to'g'ri, lekin turgan o'rni noto'g'ri
2	0	6	Bu qatorda ikkita raqam to'g'ri, lekin o'rni boshqa
7	3	8	Bu qatorda hech qaysi raqam to'g'ri emas
7	8	0	To'g'ri raqam bitta, lekin o'rni boshqa joyda

8. Nok olmadan og'irroq, shaftoli olmadan yengilroq. Ushbu mevalardan eng og'irini toping.
9. Pushti minora qizil minoradan balandroq, ammo yashil minoradan pastroq. Kumush minora yashil minoradan balandroq. Qaysi minora eng balandi?

10. Bitta anor va bitta nokning birgalikdagi og'irligi bitta olma va bir bosh uzum og'irligi bilan teng. Agar anor olmadan ko'ra og'irroq ekani ma'lum bo'lsa, bir bosh uzum va bitta nokdan qaysi biri og'irroq?
11. Sardor Ahmaddan novcharoq, Ahmad esa Bunyoddan pakanaroq. Do'stlar orasida eng bo'yi novchasi qaysi?
12. Mushuk Tom 2021-yil fevral oyida jami 3 hafta uxladi. Bu oyda mushuk Tom necha soat uyg'oq bo'lgan?
13. 13 nafar bola bekinmashoq o'ynayapti. Ularning bittasi boshqalarni izlayapti. U 5 minutda 9 nafar do'stini topdi. Izlayotgan o'quvchi yana nechta bolani topishi kerak?
14. Agar Shavkat ertalab maktabga borish uchun uydan soat 8:00 da chiqsa, darsga 10 minut kechikadi. U bugun uydan soat 7:45 da chiqdi, lekin yo'lda do'stini kutish uchun odatdagidan 10 minut ko'proq vaqt sarfladi. Endi u darsga qancha erta yoki kech boradi?
15. Said robototexnika to'garagida raqamli soat yasadi. Soatning ekranidagi qizil chiziqli LED chiroqlar yonadi va vaqtni ko'rsatadi. Ushbu raqamli soat 8:30 ni ko'rsatsa, ekranga o'rnatilgan LED tasmaning yoritilgan qismi uzunligi 45 cm. Agar ushbu raqamli soat 9:15 ni ko'rsatsa, yonib turadigan LED tasma uzunligi necha santimetr bo'ladi?

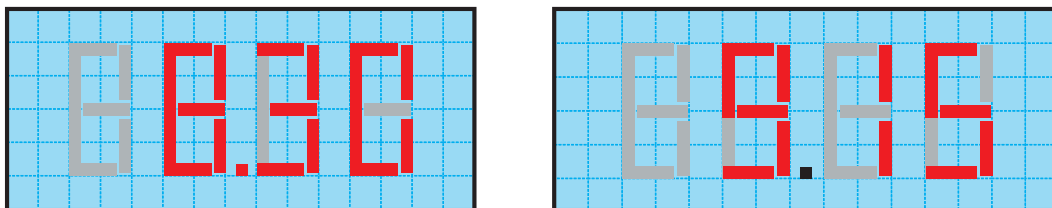

16. Ushbu rasmda qaysi shakllardan foydalanilgan va ular nechtadan?

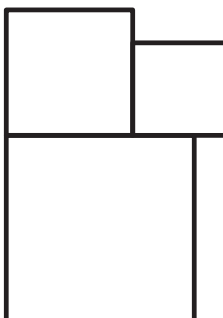

17. Uyning poydevorini qurish uchun 1 hafta va 1 kun kerak bo'ldi. Keyin asosiy devorlarni qurishga 6 hafta 4 kun, uyni elektr va gaz bilan ta'minlash ishlariga 5 kun kerak bo'ldi. Oxirida quruvchilar uyni suvadilar va mebellarni o'rnatdilar. Uyni qurish boshlanganidan oxirgi mebel o'rnatilguncha jami 9 hafta sarflangan bo'lsa, uyni suvash va mebellarni o'rnatish uchun qancha vaqt sarflangan?

- 18.** Bitta tort pishirish uchun 2 kg shakar va 5 kg un ishlatiladi. Nodira tort pishirish uchun 30 kg shakar va 50 kg un sotib oldi. Buyurtmalarni bajarib bo'lgach, u 16 kg shakar ortib qolganini aniqladi. Bunda qancha un ortib qolgan?
- 19.** Tanlovda har bir o'quvchiga 3 tadan rasm chizish topshirig'i berilgan. Musobaqada jami 24 nafar o'quvchi qatnashyapti. Topshiriqni yakunlash uchun 10 minut qolganda jami 54 ta rasm topshirilgani ma'lum bo'ldi. Hozirgacha nechta o'quvchi o'z rasmlarini chizib topshirmagan?
- 20.** O'quvchilar maktab oldidagi yo'l yoqasiga terak ekyapti. Ular ikkita terak orasini 4 metrdan tashlab, jami 12 ta terak ekishdi. Birinchi va oxirgi teraklar orasidagi masofani aniqlang.
- 21.** Rasmda 3 ta kvadrat berilgan. Eng kichik kvadrat tomonining uzunligi 6 cm ga teng bo'lsa, eng katta kvadratning tomonlari uzunligi nechaga teng?
- 
- 22.** Alisher va Bahodir uzunligi 3 metr bo'lgan 4 ta xodani yarim metrli bo'laklarga ajratish uchun arralayapti. Jami bunday bo'laklardan 24 ta hosil bo'ldi. Buning uchun bolalar jami nechta arralashni amalga oshirgan?
- 23.** Ali, Vali va G'ani og'irliklarini bilish uchun taroziga chiqishdi. Ali va Valining birgalikdagi og'irligi 80 kg chiqdi. Ali va G'anining og'irligi esa 78 kg chiqdi. Vali va G'anining birgalikdagi og'irligi 84 kg ekan. Har bir bolaning og'irligi qanchadan?
- 24.** Laboratoriyada 10 ta grammlı toshcha turibdi. Ularning og'irliklari mos ravishda 1 gramm, 2 gramm, 3 gramm va hokazo, oxirgi tosh 10 gramm. Birinchi laborant bulardan jami og'irligi 15 gramm chiqadigan 2 ta toshni oldi, ikkinchisi umumiy og'irligi 36 gramm bo'lgan 6 ta toshni oldi. Uchinchi laborant ortib qolgan ikkita toshdan yengilrog'ini oldi. Qaysi og'irlikdagi toshni hech kim olmagan?
- 25.** Akmalning o'g'il bola sinfdoshlari soni qiz bola sinfdoshlari sonidan ikki marta kam. Akmal o'qiydigan sinfda qiz bolalar soni o'g'il bolalardan 8 ta ko'p. Akmal o'qiydigan sinfda nechta o'quvchi bor?
- 26.** Bahrom bahorda ijara shartnomasi bilan 50 yilga bog' uchun yer oldi. U olma bog'i yaratishni mo'ljalladi. Bahromga eni 65 metr, uzunligi 85 metrli joy berishdi. U ko'chatlarning orasini 4 metrdan qilib o'rik va olma ekdi.  
Bahrom necha ar joy olgan?  
U eng ko'pi bilan necha tup olma daraxti eka oladi?
- 27.** Fermer qoramollar uchun molxona qurdirdi. Uning uzunligi 65 metr, eni esa 42 metr. Fermerga qancha joy kerak bo'lgan?
- 28.** To'g'ri to'rtburchak eni 30 cm, balandligi undan 3 marta qisqa. Perimetri shu to'g'ri to'rtburchakka teng kvadratning tomonini toping.



29. Kvadratning tomoni 60 dm ga teng. Uning perimetriga teng to'g'ri to'rtburchakning tomonlaridan biri 40 dm bo'lsa, shu to'g'ri to'rtburchakning ikkinchi tomonini toping.
30. Quyidagi 4 ta kvadratning qaysi birida qora rangli qismi eng ko'p?

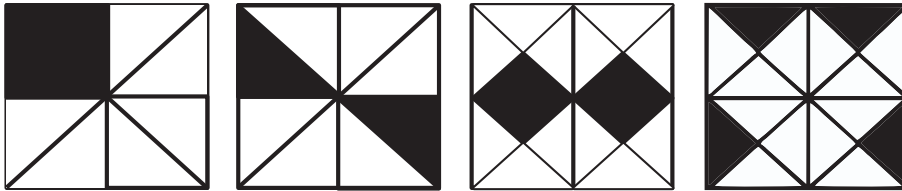

31. Malika bir-biriga ulangan tayoqchalar bilan o'ynamoqda (rasmga qarang). Quyidagi shakllardan qaysi birini Malika yasay olmaydi?



32. Berilgan shaklning yuzini toping.

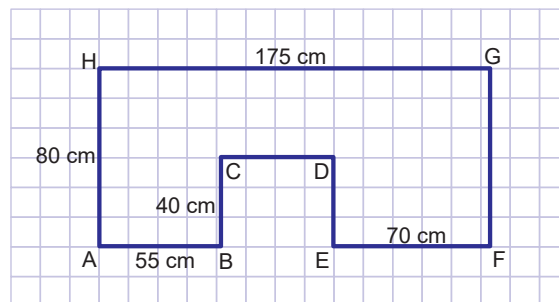

33. Men bir son o'yladim. Agar undan 42 ni ayirib, ayirmani 12 ga ko'paytirsam 1 080 hosil bo'ldi. Men o'ylagan sonni toping.
34. Biror natural son o'ylandi. U son 4 ga bo'linsa va bo'linmaga 6 qo'shilsa, 24 hosil bo'ladi. Qanday son o'ylangan.
35. Ikkita ketma-ket kelgan toq sonlar yig'indisi 452 ga teng. Shu sonlarni toping.
36. 100 ta qush 100 kunda 100 kg don yeydi. 10 ta qush 10 kunda necha kilogramm don yeydi?
37. Abdulhaq otaning yoshi 90 da, nabiralari yoshlarining o'rta arifmetigi 24 ga teng. Agar Abdulhaq otaning yoshini ham jami nabiralari yoshi yig'indisiga qo'shib, o'rta arifmetik qiymat hisoblansa, u 26 ga teng bo'ladi. Abdulhaq otaning nechta nabirasi bor?

## XALQARO BAHOLASH DASTURIGA OID TOPSHIRIQLAR

1. Ixtiyoriy  $n$  natural son uchun quyidagi tasdiqlar to'g'ri yoki noto'g'riligini aniqlang.

- A)  $n + 4 = 4 + n$       B)  $n - 5 = 5 - n$   
 C)  $n \times 6 = 6 \times n$       D)  $n \div 7 = 7 \div n$

2. Quyidagi nisbatlardan qaysi biri 1:4 ga teng?

- A) 4:16      B) 4:7      C) 4:5      D) 4:1

3. Maryam 4 xil gul sotadi. U bir xil miqdorda lola va orxideya sotdi.

A) Sotilgan lolalar barcha sotilgan gullarning necha foizini tashkil qilgan?

B) Maryam 40 ta chinnigul sotdi. U jami nechta gul sotgan?

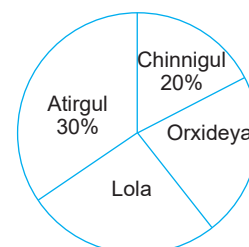

4. Kitob sotuvchisi 2022-yilning dastlabki 6 oyida sotilgan kitoblarni aks ettiruvchi quyidagi diagrammaga qarab shunday dedi: "Mart oyida men fevralga qaraganda 4 barobar ko'p kitob sotdim". Siz sotuvchining gapiga qo'shilasizmi?

O'z javobingizni izohlang.

- A) qo'shilaman      B) qo'shilmayman

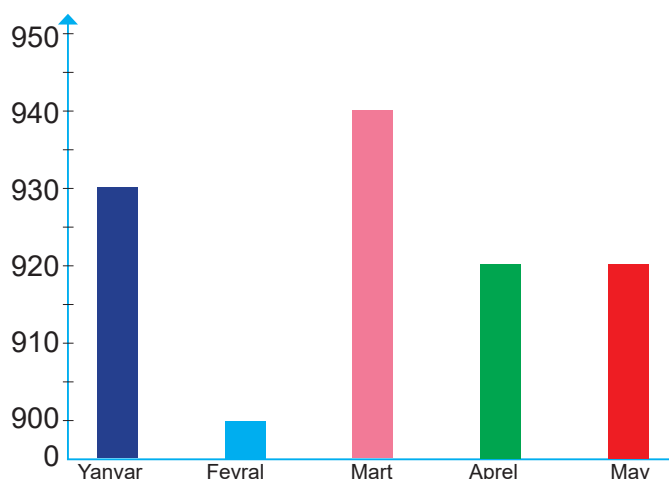

5. Sinf o'quvchilari muzeyga ekskursiyaga borishmoqchi. Butun sinf o'quvchilarining tushligi  $a$  so'mga tushadi. Har bir o'quvchining muzeyga kirish chiptasi 10 000 so'm. Sinfda  $x$  nafar o'quvchi bor. Bu ekskursiyaning umumiy xarajati  $k$  so'mni tashkil qiladi.  $k$  ning qiymatini hisoblash uchun ifoda tuzing.

6. 4 ta fandan o'tkazilgan eng yuqori 10 balli testdan Abror quyidagicha ball oldi: 9, 7, 8, 8. U yana eng ko'pi bilan 10 ball berilishi mumkin bo'lgan 1 ta testni bajarishi kerak. Abror barcha fanlar bo'yicha o'rtacha balli 9 bo'lishini xohlaydi.

Buning iloji bormi? Javobingizni izohlang.

- A) ha      B) yo'q

7. 100 ta o'quvchining bo'yi 5 cm xatolik bilan o'lchab chiqildi.

Quyidagi jadvalda olingan natijalar keltirilgan.

Bo'yi (cm)	145	150	155	160
O'quvchilar soni	16	40	25	19

Bu ma'lumotlardan foydalanib ustunli diagrammani tuzing.

8. Po'lat 7 nafar o'g'il bola va 7 nafar qiz boladan kun davomida necha soat elektron qurilmalardan foydalanishi haqida so'radi. So'rovnomaning natijasi jadvalda keltirilgan.

	Kun davomida elektron uskunalardan foydalanilgan soatlar	Umumiy soatlar
O'g'il bolalar	1 2 3 3 3 4 5	21
Qiz bolalar	1 1 2 2 3 3 3	15

Quyidagi ko'rsatkichlarning qiymatini toping:

- o'g'il bolalar ma'lumotlarining o'rtacha arifmetik qiymati;
  - o'g'il bolalar ma'lumotlarining soni;
  - qiz bolalar ma'lumotlarining modasi;
  - qiz bolalar ma'lumotlarining medianasi.
9. Agar quyidagi tenglik o'rinli bo'lsa,  $n$  qiymatini toping.  $\frac{8}{12} = \frac{24}{2n}$
10. Sizda 2 ta tuxum va 0,3 litr sut talab qilinadigan tort retsepti bor. Oshxonangizda 5 ta tuxum borligini bilgan holda, imkon qadar katta tort pishirmoqchisiz. Buning uchun necha litr sut kerak bo'ladi?
11. Diyor kvadratlarning ketma-ketligini tuzmoqda. Har safar u kvadrat tomonini bir xil songa oshirib bormoqda. Quyida bu ketma-ketlikning dastlabki uchta kvadrati ko'rsatilgan. Beshinchi kvadratning yuzini toping.
- A)  $10 \text{ cm}^2$       B)  $16 \text{ cm}^2$       C)  $25 \text{ cm}^2$       D)  $100 \text{ cm}^2$

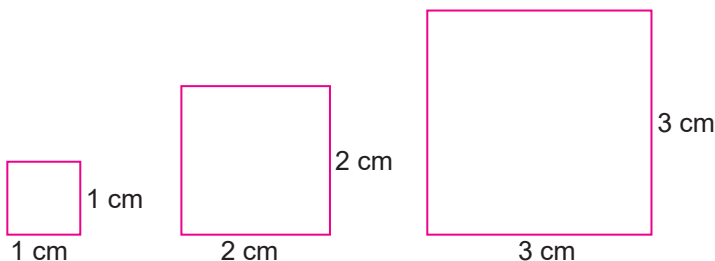

12. Umid va Kamron turli do'konlardan bir xil xokkey klyushkalarini sotib oldi. Bunday xokkey klyushkalarining odatiy narxi bir xil bo'lsa-da, Umid shu narxning  $\frac{3}{4}$  qismiga sotib oldi. Kamron esa odatiy narxdan 20% chegirma bilan xarid qildi. Ulardan qaysi biri o'z klyushkasi uchun kamroq xarajat qilgan? Javobingizni izohlang.

13. Lobar berilgan shakldan kub yasadi.  
Bu kubda Q harfi tushirilgan yoqning qarshisida qaysi yoq bo'ladi?

A) P                      B) S                      C) T                      D) U

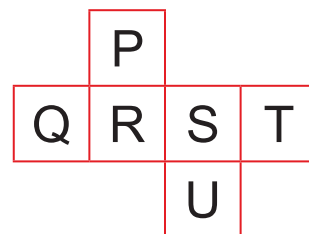

14. Har bir urug'ning o'z unish davri va harorati bo'ladi.

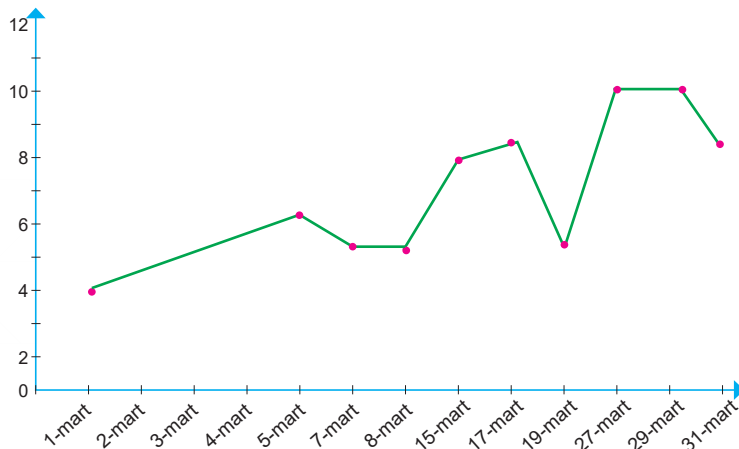

1-savol. Shivit urug'ini mart oyi kunduzgi +6 °C dan past bo'lmagan haroratda ekish tavsiya qilinadi. Chizmada mart oyida havoning o'zgarish grafigi keltirilgan. Qaysi kunlari ushbu urug'ni sepush mumkin deb hisoblaysiz?

2-savol. Agar mart oyining birinchi kuni payshanbaga to'g'ri kelgan bo'lsa, siz esa faqat dam olish kunlari ekish imkoniyatiga ega bo'lsangiz, oyning qaysi kunida shivit urug'ini eka olasiz?

15. Akmal sayohat davomida necha kilometr masofani bosib o'tishini aniqlash uchun 1:50 000 masshtabdagi xaritadan viloyatlar orasidagi masofani o'lchadi va 70 km/h tezlik bilan harakatlenganda necha soatda yetib borishini hisoblab chiqdi. Akmal necha kilometr masofani bosib o'tadi deb hisoblaysiz? U muammoni hal qilishda qayerda xatoga yo'l qo'ydi?

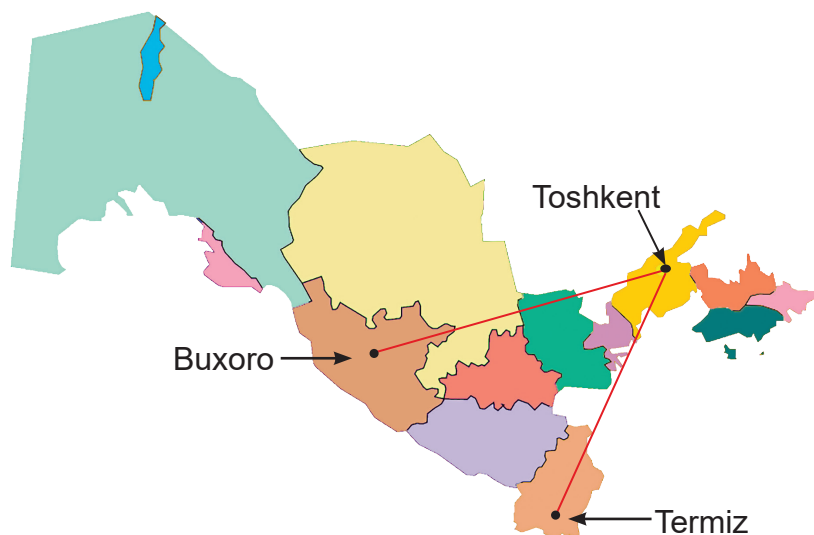

16. Tadbirkor tikuv fabrikasiga gazlama sotib olmoqchi. Unga ta'minotchi quyidagi narxlarni taklif qildi.

1 m – 15 000 so'm                      1 kg – 14 000 so'm (1 kg mato 80 cm)

Qaysi taklifni qabul qilish foydaliroq?

Fabrika 250 000 000 so'm pulga eng ko'pi bilan qancha (metr) gazlama xarid qila oladi?

17. Tadbirkor hududidagi 10 ta xo'jalikdan yig'ib olinadigan sutni qadoqlab, do'konlarga topshiradi. Laboratoriya natijalariga ko'ra, 1-, 3-, 4-, 6-, 8- va 10-xonadonlardan yig'ilgan sutlar yog'ililigi 2%, 2-, 5- va 7-xonadonlardan yig'ilgan sutlar yog'ililigi 3,5%, 9-xonadondan yig'ilgan sutning yog'ililigi esa 1%.



Savol. Agar bugun tadbirkor berilgan jadval asosida sut yig'ib olgan bo'lsa, u do'konga necha foiz yog'ililikdagi sut topshiradi?

Xonadon raqami	1	2	3	4	5	6	7	8	9	10
Litr	8	12	4	7	4	7	4	9	10	8

18. Mulohazalarni tekshiring.

Mulohaza	Har doim to'g'ri	Ba'zan to'g'ri	To'g'ri emas
Bir xil hajmli moddalarning zichligi kattasi og'ir bo'ladi.			
Perimetrlari teng bo'lgan to'rtburchaklar ichida eng katta yuzalisi – kvadrat.			
2 ga va 5 ga bo'linadigan sonlar 4 ga ham bo'linadi.			

Qirralari yig'indisi teng bo'lgan parallelo- pipedlarning eng katta hajmlisi – kub.			
Ikki tub sonning yig'indisi har doim juft son.			
Ikki toq sonning ko'paytmasi – toq.			
Aylana radiusini 2 marta orttirsak, yuzi 4 mar- ta ortadi.			
Kvadratning bo'yi 12 cm va eni 5 cm bo'lsa, uning yuzi $60 \text{ cm}^2$ bo'ladi.			
Oddiy kasrlarning yig'indisi natural son bo'la olmaydi.			
Har xil maxrajli kasrlarni qo'shishda suratlari suratiga, maxrajli maxrajiga qo'shiladi.			
Masshtab 1 000:1 ko'rinishida berilgan bo'lsa, hujayraning haqiqiy o'lchamini topish uchun 1 000 ga ko'paytirish kerak.			
Dushmani “–”, do'stni “+” bilan ifodalasak, dushmanimning dushmani “–” bo'ladi.			
Dushmani “–”, do'stni “+” bilan ifodalasak, do'stimning dushmani “–” bo'ladi.			
Do'stni “+”, dushmani “–” bilan belgilasak, do'stimning do'sti “–” bo'ladi.			
Har qanday manfiy son noldan katta.			
Son o'qida 8 va 9 sonlari orasida cheksiz ko'p sonlar bor.			
Har qanday natural songa teskari son bu natural sondan kichikdir.			
Istalgan sonni yaxlitlaganimizda bu sondan katta son hosil bo'ladi.			
O'nli kasrning teskarisi noto'g'ri kasr bo'ladi.			
Istalgan 2 ta tub son yig'indisi juft sonidir.			

*O'quv nashri*

# **MATEMATIKA**

*Umumiy o'rta ta'lim maktablarining  
6-sinfi uchun darslik*

*Muharrir Orifjon Madvaliyev  
Badiiy muharrir Sarvar Farmonov  
Rassom Umid Sulaymonov  
Dizayner Alimardon Aqilov  
Texnik muharrir Akmal Sulaymonov  
Sahifalovchi Shaxobiddin Maxmadiyev  
Musahhah Xurshidbek Ibrohimov*

Bosishga 27.07.2022-yilda ruxsat etildi. Bichimi 60x84  $\frac{1}{8}$ .  
Arial garniturası. Kegli 12. Ofset bosma.  
Shartli bosma tabog'i 27,90. Nashriyot-hisob tabog'i  
20,95. Adadi 000 000 nusxa. Buyurtma № 0000.

## Ijaraga beriladigan darslik holatini ko'rsatuvchi jadval

№	O'quvchining ismi va familiyasi	O'quv yili	Darslikning olingandagi holati	Sinf rahbari-ning imzosi	Darslikning topshiril-gandagi holati	Sinf rahbari-ning imzosi
1.						
2.						
3.						
4.						
5.						
6.						

**Darslik ijaraga berilib, o'quv yili yakunida qaytarib olinganda yuqoridagi jadval sinf rahbarlari tomonidan quyidagi baholash mezonlariga asosan to'ldiriladi:**

<b>Yangi</b>	Darslikning birinchi marta foydalanishga berilgandagi holati.
<b>Yaxshi</b>	Muqova butun, darslikning asosiy qismidan ajralmagan. Barcha varaqlari bor, yirtilmagan, ko'chmagan, betlarida yozuv va chiziqlar yo'q.
<b>Qoniqarli</b>	Muqova ezilgan, birmuncha chizilib, chetlari yedirilgan, darslikning asosiy qismidan ajralish holati bor, lekin qoniqarli ta'mirlangan. Ko'chgan varaqlari qayta joylangan, ayrim betlariga chizilgan.
<b>Qoniqarsiz</b>	Muqova yirtilgan, ustiga chizilgan, asosiy qismidan ajralgan yoki butunlay yo'q, qoniqarsiz ta'mirlangan. Betlari yirtilgan, varaqlari yetishmaydi, chizib, bo'yab tashlangan. Darslikni tiklab bo'lmaydi.